



OXARC

WHOLESALE

- **Fire Extinguisher Parts**
- **Fire Extinguisher Powder**
- **Fire Extinguisher Chemicals**
- **Fire Hose, Nozzles**
- **Portable Fire Extinguishers**
- **Restaurant & Ind. System Parts**
- **Cabinets, Accessories & Covers**
- **Signs, Labels & Tags**
- **Fire Alarm Products**
- **Safety Products**
- **First Aid Products**
- **Service Equipment**



www.oxarc.com 1-877-737-8404 wholesale@oxarc.com

Terms & Conditions

Terms

- Net 30 days from date of invoice.
- A service charge of 1-3/4% (21% annually)
- Credit Cards accepted:
Visa, Master Card & American Express
- EFT
Electronic Fund Transfers can be arranged

Returned Goods:

Products ordered in error must be returned within 30 days of receipt at customers expense, and are subject to a 15% restocking fee. All goods must be new and in unopened original packaging.

Products shipped in error may be returned within 10 days for full credit.

All returns must be accompanied by a returned goods authorization. Special orders and non-stock items are subject to the manufacturer's return policy.

Damaged Shipments:

All damage must be reported at time of receipt. Short pays for damage not reported will not be accepted.

Pricing:

All prices are subject to change without notice. We are Not responsible for errors in printing.

Warranty:

We make no representation in warranty, expressed or implied, arising out of or in connection with the sale, manufacture, delivery or use of any products offered in this catalog.

New Accounts:

See our "Online" credit application and instructions or call us at 1-800-765-9055. We offer "Same-Day" credit approval.

Free U.S.A Freight Terms:

- Small parts orders over \$250.00 shipped UPS to a single location will qualify for free freight; excluding Heavy-Duty Vehicle Brackets, liquid or powder agents and extinguishers. Haz-Mat fees not included on cartridges and pressurized extinguishers.
- Orders that must be sent auto freight from our Spokane, WA location may qualify for free freight. Next-Day, 2nd-Day, 3rd-Day select shipping is offered but freight charges apply.



WHOLESALE

When ordering, you can choose any of the following:



Phone Orders & Customer Service

1-877-737-8404

8:00am – 5:00pm PST

Monday – Friday



Fax Orders & Quotes

1-877-737-8304

8:00am – 5:00pm PST

Monday – Friday



Mail Orders

OXARC, Inc.

3417 E Springfield

Spokane, WA 99202



Online Orders

Online Orders – Safe, Secure, Fast

Web: www.oxarc.com

Email: wholesale@oxarc.com



Table of Contents

<i>FIRE EXTINGUISHER PARTS & ACCESSORIES</i>	<i>7</i>
O.E.M. VALVE STEMS _____	7
COMPONENT O-RINGS _____	10
O.E.M. FIRE EXTINGUISHER SPRINGS _____	12
U.L. LISTED FIRE EXTINGUISHER GAUGES _____	12
ADAPTERS _____	13
CO2 SAFETY DISKS _____	13
GENERIC CO2 PARTS _____	14
ANSUL REDLINE PARTS _____	14
PULL PINS _____	16
FIRE EXTINGUISHER NOZZLES _____	17
FIRE EXTINGUISHER HANDLES & LEVERS _____	18
WHEELED UNIT MOISTURE SEALS _____	19
FIRE EXTINGUISHER SIPHON TUBES _____	19
FIRE EXTINGUISHER HOSES _____	19
FIRE EXTINGUISHER WALL HANGERS _____	20
I-BEAM BRACKET _____	21
VEHICLE BRACKETS _____	21
HEAVY DUTY VEHICLE BRACKETS _____	23
EXTREME VEHICLE BRACKETS _____	23
FIRE EXTINGUISHER COVERS _____	23
HIGH VISIBILITY - MEDIUM DUTY - ORANGE _____	24
FIRE EXTINGUISHER COVERS _____	24
MSHA COMPLIANT HIGH VISIBILITY FIRE EXTINGUISHER COVERS W/WINDOW AND 2" REFLECTIVE STRIPE _____	24
HOSE STRAPS _____	24
COVERS _____	25
<i>SERVICE EQUIPMENT</i>	<i>26</i>
QUICK DISCONNECTS _____	26
RECHARGE ADAPTERS _____	26
BLOW GUN _____	27
VERIFICATION OF SERVICE COLLARS _____	27
CUSTOMIZED VERIFICATION OF SERVICE COLLARS _____	27
BULLS EYE TAMPER SEALS _____	28

BULLS EYE FLAG SEALS _____	28
SIX YEAR MAINTENANCE LABELS - CUSTOMIZED _____	29
HYDROTEST/6-YEAR COMBO LABELS _____	29
HYDROTEST LABELS - CUSTOMIZED _____	29
CALIFORNIA HYDROTEST LABELS- CUSTOMIZED _____	29
“TAMPER-EVIDENT” ADHESIVE LABELS - CUSTOMIZED _____	30
HOLE PUNCHES _____	30
VALVE CLEANING BRUSHES _____	31
TAGS, DIAMOND CLIPS & WIRES _____	31
SPRAYS & LUBES _____	32
REGULATORS _____	33
SCALES _____	34
INSPECTION LIGHTS _____	34
THERMOMETER _____	34
WHEELED UNIT KIT _____	34
SIGNS _____	35
RESTAURANT SYSTEM SIGNS _____	37
FIRST AID SIGNS _____	37
<i>FIRE EXTINGUISHERS</i> _____	38
ANSUL SENTRY FIRE EXTINGUISHERS _____	38
AMEREX FIRE EXTINGUISHERS _____	42
BADGER FIRE EXTINGUISHERS _____	44
BUCKEYE FIRE EXTINGUISHERS _____	45
<i>WET & DRY CHEMICALS</i> _____	47
WET CHEMICALS _____	47
DRY CHEMICALS _____	48
<i>FIRE SYSTEM PARTS & ACCESSORIES</i> _____	49
GENUINE GLOBE FUSIBLE LINKS _____	49
ANSUL R-102 SYSTEM PARTS _____	50
RANGEGUARD SYSTEM PARTS _____	53
AMEREX SYSTEM PARTS _____	54
PYROCHEM SYSTEM PARTS _____	55
UL LISTED PIPE SEALS _____	57
UL LISTED COMPRESSION SEALS _____	57

UL LISTED CORNER PULLEY SEALS _____	57
UL LISTED HOOD PATCH SEALS _____	57
MISCELLANEOUS FIRE SYSTEM PARTS _____	57
CABINETS _____	59
LOCKS _____	59
CATO CHIEF EXTINGUISHER CABINETS _____	59
WEST PLASTIC EXTINGUISHER CABINETS _____	59
JL FIRE EXTINGUISHER CABINETS _____	60
STRIKE FIRST APEX SEMI-RECESSED CABINETS _____	62
REPLACEMENT GLASS _____	62
FSP INDUSTRIAL PRODUCTS EXTINGUISHER CABINETS _____	63
FIRE HOSE & NOZZLES _____	65
HOSE NOZZLES - POLYCARBONATE _____	65
PLASTIC CAPS FOR HYDRANTS & STANDPIPES _____	65
ALUMINUM, BRASS OR STEEL COUPLERS, ADAPTERS, CAPS & PLUGS _____	65
EMERGENCY LIGHTING _____	66
CONTRACTOR GRADE THERMOPLASTIC LED UNITS _____	66
BARRIERS _____	67
FSP INDUSTRIAL PRODUCTS SAFETY BARRIERS _____	67
SAFETY & PERSONAL PROTECTIVE EQUIPMENT _____	68
GLOVES _____	68
VESTS _____	70
SAFETY GLASSES _____	72
HARD HATS _____	72
UTILITY KNIFE _____	73
PROTECTIVE SUITS _____	73
FIRST AID _____	75
ADHESIVE BANDAGES _____	75
WOUND CARE PRODUCTS _____	75
ELASTIC WRAPS, GAUZE ROLLS AND TAPES _____	76
TRAUMA DRESSING _____	76
LATEX GLOVES _____	76
MISCELLANEOUS _____	76
TABLETS _____	77

BURN CARE PRODUCTS	77
HOT/COLD PACKS	77
EYE WASH/SKIN FLUSHING PRODUCTS	78
LENS CLEANING	78
CPR PRODUCTS AND OXYGEN	78
UNITIZED FIRST AID	79
FIRST AID KITS	80



FIRE EXTINGUISHER PARTS & ACCESSORIES

O.E.M. VALVE STEMS

GENUINE ANSUL VALVE STEMS

	Part Number	Compatible With Model Numbers	Price Ea.
	XVKIT	OXARC Valve Stem Kit Includes 10ea of the following valve stems: 54227, 24489, 429099 (20), 103215W, 12426, 19010, 23389, 103214W, 440020K, 440068K, 877546K, A6092, A6093, A14878. Total of 150 valve stems	\$450.00
	24489	SY0513, SY0514, SY1013, SY1014, SY1015, SY1023, SY1024, SY1033, SY1034, SY2013, SY2014, SY2023, SY2024, SY2034, CA0681, CA0981, CA1381, CA1081, CA1481	\$3.60
	429099	A02, C02, A05, AA05, PK05, A05VB, AA05VB, C05, A10H, AA20, PR20, C20 FE02VB, FE05, FE09, FE13, W02-1, K01-1, K01-2	\$3.60
	54227	ST212, SY214, SY0215, SY0216, ST0236	\$3.60
	416033 (Brass)	SY0614B, SY1014B, SY1024B, SY1034B, ST2014B, SY2024B, SY2034B	\$9.99
	79806 (CO2)	ST0571, SY0872, SY1071, SY1571, SY2071, SY1072, SY1572, SY2072	\$25.27
	418682	Valve Stem Only. ST0571, SY0872, SY1071, SY1571, SY2071, SY1072, SY1572, SY2072	\$6.75
	419009 (CO2) (429154)	CD05A-1, CD05-1, CD10A-1, CD10-1, CD15A-1, CD15-1, CD20A-1, CD20-1	\$10.85
	416698	Ansul IND-X Valve Stem	\$25.60

STRIKE FIRST VALVE STEMS



	SF110427	Strike First Valve Stem	\$2.75
	SF161428	Strike First Valve Stem	\$3.25

FIRE EXTINGUISHER PARTS & ACCESSORIES



GENUINE AMEREX VALVE STEMS

	Part Number	Compatible With Model Numbers	Price Ea.
	A6092	Fits all Aluminum Headed Dry Chemical & Halon Extinguishers	\$2.10
	A6093	Fits all High Performance & Standard Brass Headed Dry Chemical, Halon, Water & Foam Fire Extinguishers	\$2.30
	A14878	Fits all K-Class Fire Extinguishers Amerex Model B260, B262	\$6.90
	A13288	Fits all Brass Headed Halotron Extinguishers (Green Rubber)	\$3.65
	A14327	Fits all Aluminum Headed Halotron Extinguishers (Green Rubber)	\$3.75
	A1539	Fits all Carbon Dioxide Fire Extinguishers	\$4.75
	A6022	50 Lb. Stored Pressure Wheeled Unit	\$17.00
	A5067	125 Lb., 150 Lb. & 250 Lb. Stored Pressure Dry Chemical, Halon Wheeled Units	\$10.50
	A9897	50 Lb. & 100 Lb. CO2 Wheeled Units	\$27.60
	A16668	65 Lb. & 150 Lb. Halotron Wheeled Units	\$12.00



GENUINE BADGER VALVE STEMS

	19010	Small Aluminum 250 & 275, 5 Lb. & 10 Lb.	\$3.15
	12426	Large Aluminum & Brass 10M-1, 20 Lb., B10M-1, B20M, B20P, B20BC	\$3.60
	23389	Badger Valve Stem	\$3.60



FIRE EXTINGUISHER PARTS & ACCESSORIES

	Part Number	Compatible With Model Numbers	Price Ea.
	23355	Halotron Fire Extinguishers 2.5HB-1, 5HB-1 With Yellow Dot	\$4.50
	23086	Halotron Fire Extinguishers 11HB, 15.5HB With Yellow Dot	\$5.50
	20981 (CO2)	B5V, B10V, B15V, B20V	\$7.00

GENUINE BUCKEYE VALVE STEMS



	103214W	Buckeye Valve Stem – Halon	\$5.30
	103215W	Fits all Dry Chemical Aluminum Head Fire Extinguishers	\$4.00
	103216W	Buckeye Valve Stem – Halotron	\$5.75

GENUINE KIDDE VALVE STEMS

	440068K	Kidde Valve Stem	\$1.95
	440020K	Kidde Valve Stem	\$1.95
	877546K	Kidde Valve Stem	\$1.95

	XO29*	Ansul 56909 - K101-1, K01-2, W02-1 Amerex 5240 - 424, B424, 461, B461, 426, B426, 419, 441, B441, 447, B447, 460, B460, 423, 408, 415, 621, 692, 693, 270, 272, B270NM, B272NM, 260, B260, 262, B262, 240, 250, 252, 254, 294, 295, 581, 580, 584, 582, 567, 569, 568, 599, 564, 566, 589, 591, 592, 570, 571, B570, B571, 495, 496, 497, 473, 474, 475, B369, B371, 361, 695, 611 Badger 20746 - 10M-1, B10M-1, B20M, B20P	\$0.08
	XO30*	Kidde 64350218 & 68260218	\$0.10
	XO31*	General 32518	\$0.10
	XO32*	General 33806	\$0.10
	XO37*	Buckeye 900001 - 5HISA40-ABC, 5HI-SB40-ABC, 5HISA-PK, 5.5HISA40-STD, 10HISA80-ABC, 10HISB80-ABC, 105HISA-ABC, 10THISA80-ABC, 10HISB80-ABC, 10SHISA-ABC, 10THI80-ABC, 10THISB80-ABC, 10SHISA-STD, 10HISA-PK, 10SHISA-PK, 10HISB-PK, 20HISA-ABC, 20SHISB-ABC, 20SHISA-STD, 20SHISP-PK, 30SHISB-ABC, 30SHISB-PK, 2.5SA-ABC, 2.5SA-PK, 2.5SA-STD	\$0.08
	XO39 (CO2)	Amerex 1124 - 322, 330, 331, 332 Buckeye 900329 - SCD-451-5LB CO2, 10CD-456-10LB CO2, 15CD-461-15LB CO2, 20CD-466-20LB CO2 Badger 16464	\$0.15
	XO195*	Ansul 79122	\$0.08
	XO295 (CO2)	Ansul 79805	\$0.25
	XO305*	General 35786	\$0.10
	XQ40	Ansul 1622 – SY0513, 0514, 0613, 0614, 0613, SY1013, SY1014, SY1015, SY1023, SY1024, 0624, SY1033, SY1034, SY2013, SY2014, SY2023, SY2033, SY2034, SY0614B, SY1014B, SY1034B, SY2014B, SY2024B, SY2034B	\$0.20
XQ41	Ansul 79122 - SY0212, SY0214, SY0215, SY0216, SY0236, SY0513, SY0514	\$0.20	

KIDDE Neck Ring Gaskets

	340036K	2 3/4RM-2, 2 3/4RM-3, 2 RM-4, 2 5/8TCM-2, 2 5/8TCM-3, 2 5/8TCM-4, 4TCM-3, 5TCM-2, 6RM-2, 6RM-3, 10RM-2, 10TCM-2, 20RM-2, 20RM-3, 5HM-2, 5HM-3, 9HM-2, 9HM-3, 13HM-3, 17HM-2, 20HM-2, XL5TC2, 6#TAP, 2A40BC, XL6R2, 6#RAP, 40BC, AC-2.5, XL2.5, XL2.5TC2, XL2-5TC2.3, 1A10BC, XL2.75R2, XL2.75R2-3, 10BC, EXT2A40BC, EXT 6#BC	\$0.60
	340037K	2 3/4 4RM, 2 5/8 TCM, 5TCM, 6RM, 6TCM, 10RM, 10RM-1, 10TCM, 10TCM-1, 20RM, 20RM-1, 20TCM, 20TCM-1, 2.5HM, 5HM, 9HM, 13HM-1, 17HM-1, 20HM-1, 10RAS-3, 10RAS-4, 10RAS-5, 10RAS-6, 10TAS-3, 10TAS-4, 10TAS-5, 10TAS-6, 20RAS-3, 20RAS-4, 20RAS-5, 20RAS-6, 20RAS-7, 20TAS-3, 20TAS-4, 20TAS-5, 20TAS-6, 20TAS-7, 30RAS-3, 10TAP, XL10RZ, XL10RZ-2, FA460HD	\$0.75
	259535K	Gauge O-Ring	\$0.35

FIRE EXTINGUISHER PARTS & ACCESSORIES



AMEREX O-RINGS - Halotron (Green Rubber)

	Part Number	Compatible With Model Numbers	Price Ea.
	A13305	397, 398	\$1.30
	A14268	A384T, B385TS, B386T, B394TS	\$1.25

BADGER O - RINGS - Halotron With Yellow Dot

	Part Number	Compatible With Model Numbers	Price Ea.
	23074	2.5HB-1, 5HB-1 - With Yellow Dot	\$0.75
	23089	11HB, 15.5HB - With Yellow Dot	\$1.15





O.E.M. FIRE EXTINGUISHER SPRINGS

	29256	Ansul Spring, Fits All SY Model Sentry Fire Extinguishers & CA Models Clean Guard	\$1.32
	415565	Ansul Spring, Fits All New Sentry Units	\$1.48
	A1074	Amerex Spring, Fits All Aluminum Heads	\$1.05
	A0383	Amerex Spring, Fits All Brass Heads Except CO2 Units	\$1.10

U.L. LISTED FIRE EXTINGUISHER GAUGES

These gauges contain a stainless steel tube assembly, housed in a stainless steel case with a polycarbonate lens to protect from weather, dust and corrosion.

Dry Chemical Gauges

	DC150G	150PSI Dry Chemical	\$4.90
	DC175G	175PSI Dry Chemical	\$4.35
	DC195G	195PSI Dry Chemical	\$2.50
	DC240G	240PSI Dry Chemical	\$3.05
	KDC100	100PSI Dry Chemical Kidde Gauge	\$2.50
	293266K	195PSI Dry Chemical Kidde Gauge	\$2.50
	428940	75PSI Dry Chemical Ansul FE-36 Gauge	\$5.45
	426264	125PSI Dry Chemical Ansul FE-36 Gauge	\$5.25
	SF235PSI	235PSI Dry Chemical Strike First Gauge	\$4.25

FIRE EXTINGUISHER PARTS & ACCESSORIES

Halon Gauges

	Part Number	Compatible With Model Numbers	Price Ea.
	HL100G	100PSI Halon Gauge	\$7.35
	HL150G	150PSI Halon Gauge	\$7.65
	HL195G	195PSI Halon Gauge	\$6.80

Wet Chemical Gauges

	A17420	100PSI Wet Chemical Gauge	\$9.50
---	--------	---------------------------	---------------

Water Gauges



	WA100G	100PSI Water	\$2.80
	429536	100PSI Water and Wet Chem Gauge, Ansul	\$6.60

**** Call for BULK pricing on G100WS, G195 & 293266K Gauges.**



ADAPTERS

	A0155	Amerex Schrader Valve	\$2.50
---	-------	-----------------------	---------------

CO2 SAFETY DISKS

	A4000	Amerex Safety Disk & Washer	\$7.60
	79786	Ansul Safety Disk & Washer	\$9.20
	429515	Ansul Safety Disk & Washer	\$8.65
	24643	Kidde Burst Disc Washer & Nut Assembly	\$10.30





FIRE EXTINGUISHER PARTS & ACCESSORIES

	Part Number	Compatible With Model Numbers	Price Ea.
GENERIC CO2 PARTS			
	ODC	Diffuser Clip	\$0.35
	ODN	CO2 Diffuser for RDH10 & 15	\$4.16

ANSUL REDLINE PARTS

	77250	Cartridge Shipping Cap, Left Hand	\$4.50
	77251	Cartridge Shipping Cap, Right Hand	\$4.50
	3626	Cartridge Receiver Assembly	\$49.35
	1356	Cartridge Receiver Assembly, Right Hand	\$53.82
	1057	Rubber Cap, Cartridge Receiver	\$2.50
	418023	Cartridge Guard, Composite 10-G	\$28.95
	416346	Cartridge Guard, Composite 20-G	\$28.75
	418025	Cartridge Guard, Composite 30-G	\$30.45
	181	Gasket Cartridge Receiver	\$1.00
	7066	Ring Pin	\$2.25
	7095	Ring Pin and Chain	\$5.95
	6579A	Rivet, Carry Handle	\$0.50
	6169A	Carry Handle	\$7.92



FIRE EXTINGUISHER PARTS & ACCESSORIES

	Part Number	Compatible With Model Numbers	Price Ea.
	17999	Fill Cap with Indicator	\$48.96
	6190	Fill Cap Gasket	\$2.40
	6273	Fill Cap Quad Ring	\$2.10
	17633	Indicator Cap, Plastic	\$2.05
	27648	Stem, Indicator, Red	\$5.21
	17630	Quad Ring, Ansul Redline Indicator	\$0.17
	1239	Retaining Ring, Indicator	\$1.25
	13005	Ansul 10Lb Redline Hose	\$40.98
	7091	Ansul 20Lb Redline Hose	\$46.53
	7083	Ansul 30Lb Redline Hose	\$61.12
	3651	Hanger Hook, Ansul Redline	\$2.50
	3621	Rivet, Nozzle Handle	\$0.98
	1230A	Gasket, Nozzle Tip Assembly	\$0.54
	6263	10Lb Hose O-Ring	\$2.40
	6323	20Lb Hose O-Ring	\$1.50
	6324	30Lb Hose O-Ring	\$1.75
	15999	Inspection Seal Visual	\$0.60
	56117	Nozzle Plunger	\$6.46
	3469	O-Ring, Nozzle Assembly	\$0.57

Maintain the U.L. Listing of your Redline Unit with Genuine Ansul Replacement Labels.

FIRE EXTINGUISHER PARTS & ACCESSORIES

	Part Number	Compatible With Model Numbers	Price Ea.
	416373	Maintenance Name Plate (back) for all 10-E-G, A-10-E-G, K-10-E-G units	\$11.05
	416374	Maintenance Name Plate (back) for all 20-E-G, A-20-E-G, K-20-E-G units	\$11.05
	416375	Maintenance Name Plate (back) for all 30-E-G, A-30-E-G, K-30-E-G units	\$11.05
	30789	Nozzle Assembly, Standard	\$68.10
	30778	30Lb Nozzle Assembly	\$65.00
	25780	Tip, Nozzle, HF-A, HF-K (E-G) High Flow	\$13.50
	17908	Tip, Nozzle, Plus Fifty C (E-G)	\$13.50
	30790	Tip, Nozzle, Standard A&K	\$9.00



PULL PINS			
NPP			
	CPP	Common Pull Pins (Bags of 100) (Sold by each)	\$0.14
	82448PP	Pull Pins, Shearable Plastic (Sold by Each) (Minimum 100/Bag)	\$0.19

FIRE EXTINGUISHER PARTS & ACCESSORIES



	Part Number	Compatible With Model Numbers	Price Ea.
	A0532	Amerex Pull Pin Keeper (Sold by Each)	\$0.32
	23537	Large Loop Stainless Steel Pull Pin (Sold by Each)	\$1.15

FIRE EXTINGUISHER NOZZLES



Amerex

	A1926	2-1/2 Lb., Model 417	\$2.10
	A1253	5 Lb., Model 425	\$2.30





Ansul



	428269	2-1/2 Lb., Models AO2, AO2VB, CO2VB, PC2.5VB	\$2.00
	442405	2-1/2 Lb., Models AO2S	\$2.40



Badger

	23387	2.5 Lb. Nozzle, Model B250M	\$2.25
	23487	2.5 Lb. Nozzle, Model B250P	\$2.75
	23473	2.5 Lb. Nozzle, Model B275BC	\$1.95

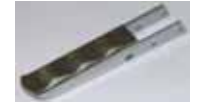

FIRE EXTINGUISHER PARTS & ACCESSORIES

	Part Number	Compatible With Model Numbers	Price Ea.
FIRE EXTINGUISHER HANDLES & LEVERS			
Amerex			
	A7762	Top Lever and Rivet Compatible w/Brass Head	\$4.70
	A9020	Bottom Handle & Rivet Compatible w/Brass Head	\$4.70
	A2625	Top Lever & Rivet Compatible w/Old Style Aluminum Head	\$2.10
	A11825	Top Lever & Rivet Compatible w/New Style Aluminum Head	\$2.95
	A11826	Bottom Lever & Rivet Compatible w/New Style Aluminum Head	\$2.10



Ansul			
	429096	Top Level Red Steel, Compatible w/ New Style Ansul Sentry Heads	\$2.30
	429097	Bottom Handle Red Steel, Compatible w/ New Style Ansul Sentry Heads	\$2.40

Badger			
	23351	Aluminum Top Lever (Small Valve Models)	\$2.40
	23353	Aluminum Bottom Handle (Small Valve Models)	\$2.40



FIRE EXTINGUISHER PARTS & ACCESSORIES

	Part Number	Compatible With Model Numbers	Price Ea.
	18361	Brass Large Bottom Handle	\$1.60
	16437	Aluminum Bottom Handle (Large Valve Models)	\$4.20
	16438	Aluminum Top Lever (Large Valve Models)	\$4.35

Buckeye

	900228W	Aluminum Bottom Handle	\$2.75
	900210W	Aluminum Top Lever	\$2.75



WHEELED UNIT MOISTURE SEALS

	A3787	Amerex Safety Disc Assembly	\$30.60
	14236	Ansul Wheeled Unit Moisture Seal	\$2.25
	14237	Ansul Wheeled Unit Moisture Seal	\$3.90









FIRE EXTINGUISHER SIPHON TUBES

	A15943	Amerex B240 Water Fire Extinguisher Siphon Hose	\$8.80
	A15941	Amerex B260 K Class Fire Extinguisher Siphon Hose	\$13.70
	439713	Ansul K Guard Siphon Hose	\$29.20

FIRE EXTINGUISHER HOSES

	428728	Ansul 5Lb Replacement Hose	\$5.65
	428732	Ansul 10Lb Replacement Hose	\$6.00
	428736	Ansul Hose and Nozzle Assembly, AA20	\$6.50
	439495	Ansul K Guard Hose & Nozzle Assembly	\$23.30
	A3339	Amerex Hose and Horn Assembly, A423	\$14.00
	A7641	Amerex Replacement Hose, A400	\$9.65
	A1178	Amerex Replacement Hose, B441 & B447	\$11.50
	A11221	Amerex Replacement Hose, A411	\$11.15
	A14849	Amerex Replacement Hose, B402	\$9.40
	A5564	Amerex Replacement Hose, B456	\$10.07



FIRE EXTINGUISHER PARTS & ACCESSORIES

	Part Number	Compatible With Model Numbers	Price Ea.
FIRE EXTINGUISHER WALL HANGERS			
Amerex			
	A1007	J-Hook	\$0.80
	A0546	5 Lb. CO2 Hook Bracket (Fits CO2 and Dry Chem)	\$0.75
	A0575A	10-15 Lb. CO2 Hook Bracket (Fits CO2 and Dry Chem)	\$0.75
	A0577	20 Lb. CO2 Hook Bracket (Fits CO2 and Dry Chem)	\$0.75
	A1521	5 Lb. Fork Bracket	\$1.05
	A5525	10 Lb. Fork Bracket	\$1.10
	A14220	Loop Hanger & Screw	\$0.90
	A15363	10 Lb. Loop Hanger & Screw	\$0.90

Ansul

	16819	5 Lb. Slot Bracket	\$3.00
---	-------	--------------------	---------------

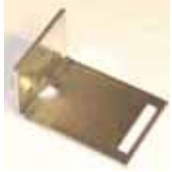
FIRE EXTINGUISHER PARTS & ACCESSORIES



	Part Number	Compatible With Model Numbers	Price Ea.
	25298	10 Lb. Slot Bracket	\$3.55
	30643	20 Lb. Slot Bracket	\$3.85
	428802	10 Lb. Hanger Adapter	\$1.50
	428800	20 Lb. Hanger Adapter	\$3.00

I-BEAM BRACKET





	IBA	I Beam Clamp to Mount Fire Extinguisher	\$1.30
--	-----	---	---------------

VEHICLE BRACKETS







Genuine Amerex

	A817	2-1/2 Lb.	\$4.90
	A818	5 Lb.	\$5.70

FIRE EXTINGUISHER PARTS & ACCESSORIES



	Part Number	Compatible With Model Numbers	Price Ea.
	A861H	5 Lb. Heavy Duty	\$15.70
	A860	HD Rubber Strap Bracket, Fits 2-1/2 Lb.	\$19.55
	A862	HD Rubber Strap Bracket, Fits 5 Lb. & 10 Lb.	\$22.30
	A864	HD Rubber Strap Bracket, Fits 20 Lb.	\$28.50
	A7802	HD Rubber Straps, Fits A864 Brackets	\$7.60
	A7166	HD Rubber Straps, Fits A860 & A862 Brackets	\$5.90

Ansul

	24610	2.5Lb Ansul Bracket	\$5.50
	14228	10Lb Ansul Redline Bracket	\$75.00
	30889	30Lb HD Ansul Redline Bracket	\$135.00
	30759	20Lb HD Ansul Redline Bracket	\$115.50
	30937	20Lb Ansul Sentry Bracket	\$55.20
	14091	20Lb Ansul Redline Bracket	\$78.50

FIRE EXTINGUISHER PARTS & ACCESSORIES

	Part Number	Compatible With Model Numbers	Price Ea.
HEAVY DUTY VEHICLE BRACKETS			
	A807	HD Black Metal Bracket, Fits 5 Lb.	\$24.80
	A809	HD Black Metal Bracket, Fits 10 Lb.	\$30.10
	A810	HD Black Metal Bracket, Fits 20 Lb.	\$32.25

EXTREME VEHICLE BRACKETS			
	UB10	HD Extreme Vehicle Bracket, 10 Lb.	\$32.15
	UB20	HD Extreme Vehicle Bracket, 20 Lb.	\$36.06

Universal Bracket			
	25SBKT	2-1/2 Lb. Universal Spring Bracket	\$3.50
	5SBKT	5 Lb. Universal Spring Bracket	\$4.00

CUSTOM LOGO FIRE EXTINGUISHER COVERS			
	ECSM	5 Lb. & 10 Lb. Dry Chemical Extinguisher Cover, 12-1/2" x 20"	\$7.75
	ECWSM	5 Lb. & 10 Lb. Dry Chemical Extinguisher Cover w/Window, 12-1/2" x 20"	\$8.00

FIRE EXTINGUISHER COVERS			
	ECSM	5 Lb. & 10 Lb. Dry Chemical Extinguisher Cover, 12-1/2" x 20"	\$7.75
	ECWSM	5 Lb. & 10 Lb. Dry Chemical Extinguisher Cover w/Window, 12-1/2" x 20"	\$8.00

FIRE EXTINGUISHER PARTS & ACCESSORIES

	Part Number	Compatible With Model Numbers	Price Ea.
	ECMD	20 Lb. and 30 Lb. Dry Chemical Extinguisher Cover, 6"x27"	\$8.50
	ECWMD	20 Lb. and 30 Lb. Dry Chemical Extinguisher Cover w/Window, 16" x 27"	\$9.50
	ECLG	15 Lb. and 20 Lb. Carbon Dioxide Extinguisher Cover, 16"x32"	\$10.00
	ECWLG	15 Lb. and 20 Lb. Carbon Dioxide Extinguisher Cover w/Window, 16"x32"	\$11.00
	ECHDSM	Heavy Duty 5 Lb. and 10 Lb. Dry Chemical Extinguisher Cover, 13"x20"	\$11.50
	ECHDMD	Heavy Duty 20 Lb. and 30 Lb. Dry Chemical Extinguisher Cover, 16" x 26"	\$14.00
	ECHD	Heavy Duty 15 Lb. and 20 Lb. Carbon Dioxide Extinguisher Cover	\$16.50

HIGH VISIBILITY - MEDIUM DUTY - ORANGE FIRE EXTINGUISHER COVERS

	ECOS	5Lb. and 10Lb. Dry Chemical Extinguisher Cover	\$11.50
	ECOM	20Lb. and 30Lb. Dry Chemical Extinguisher Cover	\$13.75
	ECOL	15Lb. and 20Lb. Carbon Dioxide Extinguisher Cover	\$14.50
	ECOWS	5Lb. and 10Lb. Dry Chemical Fire Extinguisher Cover	\$14.00
	ECOWM	20Lb. and 30Lb. Dry Chemical Extinguisher Cover	\$15.00
	ECOWL	15Lb. and 20Lb. Carbon Dioxide Extinguisher Cover	\$16.50

MSHA COMPLIANT HIGH VISIBILITY FIRE EXTINGUISHER COVERS W/WINDOW AND 2" REFLECTIVE STRIPE

	FE1HD	5Lb. - 10Lb. Orange Dry Chemical Extinguisher Cover	\$18.50
	FE2HD	20Lb. - 30Lb. Orange Dry Chemical Extinguisher Cover	\$20.25
	FE1HDR	5Lb. - 10Lb. Red Dry Chemical Extinguisher Cover	\$18.50
	FE2HDR	20Lb. - 30Lb. Red Dry Chemical Fire Extinguisher Cover	\$20.25

HOSE STRAPS

Amerex

	A15747	Small Strap with 3/8" Hose Clip. Fits 4-1/4" to 5" diameter cylinders	\$1.20
	A14778	Strap with 1/2" Hose Clip. Fits all 7" diameter cylinders	\$1.45
	A14871	Strap with 1/2" Hose Clip. Fits all 8" diameter cylinders	\$1.60

FIRE EXTINGUISHER PARTS & ACCESSORIES







	Part Number	Compatible With Model Numbers	Price Ea.
Universal			
	SSHC	Universal Hose Clip, Stainless Steel	\$0.60
	HS36	Universal Hose Strap, 36"	\$0.65

COVERS





	RE24	24" X 6" Vinyl Rack Cover	\$16.00
	WFE50HD	50lb Wheel Unit Heavy Duty Vinyl Cover	\$88.95
	WFE 125	125lb Wheel Unit Cover	\$51.00
	WFE150	150lb Wheel Unit Cover	\$55.00
	WFE350	300lb Wheel Unit Cover	\$65.00
	WFE350HD	300lb Wheel Unit Heavy Duty Cover	\$130.00

SERVICE EQUIPMENT







QUICK DISCONNECTS

	Part Number	Description	Price Ea.
	BPHC4-4F	Female without Plug	\$11.00
	BVHC44	Female with Plug	\$14.60
	BPHN42M	Male, 1/8" Thread	\$2.00
	BPHN4-4M	Male, 1/4" Thread	\$4.25
	H210	Hansen Female	\$10.15
	H2608	Hansen Male, 1/4"	\$3.05
	H2607	Hansen Male, 1/8"	\$3.05

RECHARGE ADAPTERS

	X21	OXARC Recharge Adapters w/XO8 – Fits Amerex aluminum head, Badger, General, Old Kidde & Pemall	\$5.50
	X22	OXARC Recharge Adapter w/XO8 – Fits Ansul Sentry (old style small valve)	\$5.50
	X23	OXARC Recharge Adapter w/XO95 – Fits Ansul, Buckeye, Pyronauts & Kidde (Ig Proline units)	\$5.50
	X24	OXARC Recharge Adapter w/XO10 – Fits Amerex, Ansul, Badger, General, Pemall, Buckeye, Flag, Powerpak & Rc Ind.	\$5.50

SERVICE EQUIPMENT

	Part Number	Compatible With Model Numbers	Price Ea.
	X25	OXARC Recharge Adapter w/XO115 – Fits Old Style Kidde units	\$5.50
	X26	OXARC Recharge Adapter w/XO95 – Fits RC Ind	\$5.50
	X27	OXARC Recharge Adapter w/XO8 – Fits Nylon valve Kidde with nozzle	\$7.00
	X30	OXARC Recharge Adapter w/XO17 – Fits All Old Style Large Valve Ansul Sentry units	\$5.50
	X35	OXARC Recharge Adapter w/XO9 – Fits New Ansul Sentry and Kidde Proline (small units)	\$5.50
	X36	OXARC Recharge Adapter w/XO36 – Fits Amerex 260, 262, 270, & 272	\$6.75

BLOW GUN

	F1051	Blow Gun	\$8.75
--	-------	----------	---------------



VERIFICATION OF SERVICE COLLARS

	SCSM	Green, 1-3/8" ID (100/pk), Small	\$5.00
	SCMD	Grey, 1-3/4" ID (100/pk), Medium	\$5.00
	SCLG	Blue, 2-1/2" ID (100/pk), Large	\$6.00

CUSTOMIZED VERIFICATION OF SERVICE COLLARS

					
Custom Service Collars			California Custom Service Collars		
UL Listed	CSCS	Custom Green Service Collar, 1-3/8" ID (100/pk)			\$9.50
	CSCM	Custom Grey Service Collar, 1-3/4" ID (100/pk)			\$10.50
	CSCL	Customer Blue Service Collar, 2-1/2" ID (100/pk)			\$11.50
	CASCS	California Green Customer Service Collar, 1-3/8" ID (100/pk)			\$9.50
	CASCM	California Grey Custom Service Collar, 1-3/4" ID (100/pk)			\$10.50
	CASCL	California Blue Customer Service Collar, 2-1/2" ID (100/pk)			\$11.50

SERVICE EQUIPMENT

	Part Number	Description	Price Ea.
BULLS EYE TAMPER SEALS			
	BSBK	Black (500/Bag)	\$30.15
	BSBR	Red (500/Bag)	\$30.15
	BSBY	Yellow (500/Bag)	\$30.15
	BSBO	Orange (500/Bag) (Heavy Duty)	\$30.15
	BSBW	White (500/Bag)	\$30.15
	BSBG	Green (500/Bag)	\$30.15
	BSBL	Blue (500/Bag)	\$30.15
	TSWH	Customized with your company logo	
		(12 Bags of 500)	\$40.00
		(20 Bags of 500)	\$37.50
		(60 Bags of 500)	\$36.00
		One Time Plate Charge	\$175.00

BULLS EYE II FLAG SEALS

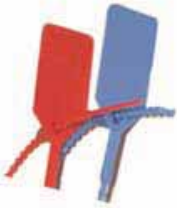
	DSRD-NON	Red (500/Bag)	\$22.50
	DSBL-NON	Blue (500/Bag)	\$22.50
	DSGR-NON	Green (500/Bag)	\$22.50
	DSBK-NON	Black (500/Bag)	\$22.50
	DSWH-NON	White (500/Bag)	\$22.50
	DSYW-NON	Yellow (500/Bag)	\$22.50
	DSOR-NON	Orange (500/Bag)	\$22.50

Heat Stamped, Two-Tone, Dated

	DSRD	Printed Seal, Red (500/Bag)	\$22.50
	DSGR	Printed Seal, Green (500/Bag)	\$22.50
	DSWH	Printed Seal, White (500/Bag)	\$22.50
	DSOR	Printed Seal, Orange (500/Bag)	\$22.50
	DSYW	Printed Seal, Yellow (500/Bag)	\$22.50
	DSBK	Printed Seal, Black (500/Bag)	\$22.50
	DSRD	Printed Seal, Red (500/Bag)	\$22.50
	DSCU	Customized with your logo, Dated or Non-Dated (500/Bag)	\$32.00
		One Time Plate Charge for Custom Seals Only	\$175.00

CUSTOM SERVICE TAGS



	CSTAGG CSTAGR CSTAGB CSTAGO CSTAGW	Weather resistant V-Max material withstands most elements Customized with your company information and most logos Available in Green, Red, Blue, Orange or White	\$14.00 per Roll of 100 Qty. Discounts Available
---	--	--	---

SERVICE EQUIPMENT



	Part Number	Description	Price Ea.
SIX YEAR MAINTENANCE LABELS - CUSTOMIZED			
	C6YR	Customized with your company name & address	
	(Sold by each)	(Roll of 100 - \$14.00)	\$0.140
		(Roll of 250 - \$32.50)	\$0.130
		(Roll of 500 - \$50.00)	\$0.100
		(Roll of 1000 - \$90.00)	\$0.090
		<i>One Time Plate Charge</i>	\$15.00

HYDROTEST/6-YEAR COMBO LABELS			
	HYDRO-COMBO	Roll of 1-499	\$0.14
	(Sold by Each)	Roll of 500-999	\$0.13
		Roll of 1000+	\$0.11
		<i>One Time Plate Charge</i>	\$15.00



HYDROTEST LABELS - CUSTOMIZED			
	CHYDRO	Customized with your company name & address	
	(Sold by each)	(Roll of 100 - \$14.00)	\$0.140
		(Roll of 250 - \$32.50)	\$0.130
		(Roll of 500 - \$50.00)	\$0.100
		(Roll of 1000 - \$90.00)	\$0.090
	<i>One Time Plate Charge</i>	\$15.00	

CALIFORNIA HYDROTEST LABELS- CUSTOMIZED			
	CCA HYDRODOT	DOT Customized with your company name & address	
	(Sold by each)	(Roll of 100 - \$11.00)	\$0.110
		(Roll of 250 - \$25.00)	\$0.100
		(Roll of 500 - \$45.00)	\$0.090
		(Roll of 1000 - \$80.00)	\$0.080
		<i>One Time Plate Charge</i>	\$15.00
	CCA HYDRONON	NON-DOT Customized with your company name & address	
	(Sold by each)	(Roll of 100 - \$11.00)	\$0.110
		(Roll of 250 - \$25.00)	\$0.100
		(Roll of 500 - \$45.00)	\$0.090
	(Roll of 1000 - \$80.00)	\$0.080	
	<i>One Time Plate Charge</i>	\$15.00	
	OXSS	Adhesive Extinguisher Tag Custom tag with monthly quick check Ships within 48 hours!	
			100 \$0.15 ea
			500 \$0.14 ea
			1000 \$0.13 ea





SERVICE EQUIPMENT

	Part Number	Description	Price Ea.
“TAMPER-EVIDENT” ADHESIVE LABELS - CUSTOMIZED			
	CELTR (Sold by each)	Emergency Lighting Testing Customized with your company name & address (Roll of 100 - \$14.00) (Roll of 200 - \$20.00) (Roll of 300 - \$24.00) <i>One Time Plate Charge</i>	\$0.140 \$0.100 \$0.080 \$15.00
	CCTL (Sold by each)	Conductivity Testing Customized with your company name & address (Roll of 100 - \$14.00) (Roll of 200 - \$20.00) (Roll of 300 - \$24.00) <i>One Time Plate Charge</i>	\$0.140 \$0.100 \$0.080 \$15.00
	CHHTL (Sold by each)	Hose Hydro-Testing Customized with your company name & address (Roll of 100 - \$14.00) (Roll of 200 - \$20.00) (Roll of 300 - \$24.00) <i>One Time Plate Charge</i>	\$0.140 \$0.100 \$0.080 \$15.00





HOLE PUNCHES

	HPLD	Light Duty Hole Punch, 1/8" Round	\$3.75
	HPMD	Standard Hole Punch, 2" Reach, 1/8" Round	\$6.75
	HPHD	Industrial Hole Punch, 1/8" Round	\$27.65





SERVICE EQUIPMENT

	Part Number	Description	Price Ea.
VALVE CLEANING BRUSHES			
	NRB	Nylon Round Brush	\$3.00
	NTB	Nylon Tooth Brush	\$1.00
	SSRB	Stainless Steel Round Brush	\$2.75
	BRB	Brass Round Brush	\$3.25
	K4WP	O-Ring Pick	\$5.50

TAGS, DIAMOND CLIPS & WIRES



	PIT	One-Year Plastic Tags, Monthly (Made in the USA)	\$0.32
	4ATAG	Non-Dated, Four-Year Metal Tags, Monthly Add date with a Sharpie or Paint Pen for more longevity on Industrial Accounts. (Made in the USA) Don't get caught with Outdated Tags!	\$0.35
	4PIT	Non-Dated, Four-Year Plastic Tags, Monthly (Made in the USA)	\$0.20
	4AIT	Non-Dated, Four-Year Adhesive Labels, Monthly	
		(Roll of 100 - \$14.00) Sold by each	\$0.12
		(Roll of 200 - \$20.00) Sold by each	\$0.10
		(Roll of 300 - \$24.00) Sold by each	\$0.08

SERVICE EQUIPMENT





	Part Number	Description	Price Ea.
	MPT-5	Tag Seal (Bag of 500) Sold by each	\$6.00
	96873	Black, Fine Tipped Paint Pen	\$3.60
	CRTAG	Customer Repair Tags, Sequentially Numbers, Looped String Attached, Perforated Customer Claim Check (100/pk) (Sold by each)	\$0.10
	TAGBAG	Tag Bag with Grommet	
		Under 250	\$.22 ea
		250-499	\$.19 ea
		500+	\$.17 ea
	DC1000	Diamond Clips (1,000/Box)	\$17.50
	W12	12" Tag Wire (1,000/Bundle)	\$9.00

SPRAYS & LUBES

Replace your Beco Lube & Crazy Kleen!

	XSA1	CRC Spray Adhesive, 16.25oz Aerosol	\$14.25
	XSL2	Alum A Lube – All Purpose Lubricating Cleaner, 9.4oz Aerosol	\$8.30
	14400	CRC Citrus Foaming Cleaner, 18oz Aerosol	\$7.55
	14424	CRC Stainless Steel Cleaner, 1 Lb., 2oz Aerosol	\$8.05



SERVICE EQUIPMENT

	Part Number	Description	Price Ea.
	SMOKE	Smoke Detector Tester, 2.5oz Can	\$11.80
	SNP8	Snoop Leak Detector, 8oz Bottle	\$6.95
	PLUBE	Parker O-Lube, 4oz Tube	\$9.50
	I-Shield	Inspecta Shield 1 Quart Bottle or 1 Gallon Jug	\$19.95 1 Qt Bottle
			\$43.50 1 G Jug
	A6247	Visilox Silicon Grease, 5oz Tube	\$27.50



REGULATORS

	25-500C-580	Nitrogen High Performance Industrial Compressed Regulator, Single & Multi-Stage	\$121.00
	5741PMHP	Carbon Dioxide Pop Regulator	\$76.05
	742	Carbon Dioxide Beer Gas Regulator	\$78.80

SERVICE EQUIPMENT

	Part Number	Description	Price Ea.
SCALES			
	T4	4Lb Portable Hanging Scale	\$53.85
	T-50	50Lb Portable Hanging Scale	\$46.00
	DIGITALSCALE	Portable Digital Hanging Scale with Hook	\$15.95
	S-15287	1Lb. Cast Iron Scale Calibration Weight	\$81.95
	S-15290	10Lb. Cast Iron Scale Calibration Weight	\$111.15

INSPECTION LIGHTS

	15150A	24" Cylinder Inspection Light, Krypton Lamp	\$41.50
	12110	Replacement Bulb for 24" Cylinder Inspection Light	\$9.50
	10150A	16" Cylinder Inspection Light, Standard Lamp	\$23.50
	12100B	Replacement Bulb for 16" Cylinder Inspection Light	\$8.00
	EMF-2	Extendable Magnetic LED Flashlight	\$18.10







THERMOMETER

	IR1000	Infrared Thermometer (-58F to 1000F)	\$95.00
--	--------	--------------------------------------	---------

WHEELED UNIT KIT

	FPS 30/350	Wheeled Unit Kit	\$464.00
---	------------	------------------	----------



SERVICE EQUIPMENT

	Part Number	Description	Price Ea.
SIGNS			
OXARC's vinyl signs are made of 3.5mil flexible white vinyl with highly flexible, high gloss UV resistant ink and permanent pressure-sensitive acrylic adhesive that bonds well to a variety of surfaces. Service temperature ranges from -40° F to 176° F.			
	V44FI	"Fire Extinguisher Inside", 4x4, Vinyl	\$0.28
	V34FIW	"Fire Extinguisher Inside", 3x4, Vinyl	\$0.28
	V44W500	"Warning \$500.00 Fine", 4x4, Vinyl	\$0.20
	V112EXW	EXIT, Red on White, 8x11, Vinyl	\$1.05
	V112EX	EXIT, White on Red, 8x11, Vinyl	\$1.05
	V26FBG	"Fire Extinguisher - In Case of Fire Break Glass", 2x6, Vinyl	\$0.28
	V412FA	"Fire Extinguisher Arrow", 4"x12", English, Vinyl	\$0.34
	V412FASP	"Fire Extinguisher Arrow", 4"x12", Spanish, Vinyl	\$0.34
	V418FA	"Fire Extinguisher Arrow", 4"x18", English, Vinyl	\$0.45
	V418FASP	"Bi-Lingual Fire Extinguisher Arrow", 4"x18", Spanish, Vinyl	\$0.45



SERVICE EQUIPMENT

	Part Number	Description	Price Ea.
	V46FA	Fire Extinguisher Arrow, 4" x 6", Vinyl Adhesive	\$0.50
	V812FA	Fire Extinguisher Arrow, 8" x 12", Vinyl Adhesive	\$0.55
	V69FI	"Fire Extinguisher Inside" Sign, 6"x9", Vinyl	\$0.60
	V1224PR	"Fire Extinguisher Arrow", Pole Wrap, 12-1/2"x24-1/4", Vinyl	\$3.85
	P412FA	Rigid Plastic "Fire Extinguisher Arrow", 4"x12"	\$1.05
	P418FA	Rigid Plastic "Fire Extinguisher Arrow", 4"x18"	\$1.35
	A412FA	Aluminum "Fire Extinguisher Arrow", 4"x12"	\$2.00
	A418FA	Aluminum "Fire Extinguisher Arrow", 4"x18"	\$2.65
	P123DFA	Three Dimensional Plastic Sign, 8"x12"	\$2.50
	P183DFA	Three Dimensional Plastic Sign, 8"x18"	\$3.70
	P412AFA	90° Plastic Sign, 12"	\$2.50
	P418AFA	90° Plastic Sign, 18"	\$3.00
	P63DFA	5"x6" 3D Fire Extinguisher Sign	\$3.00
	UN1044L	Fire Extinguisher Sticker	\$0.14
	BL188	UN1066 Nitrogen Compressed Sticker	\$0.14

SERVICE EQUIPMENT

	Part Number	Description	Price Ea.
RESTAURANT SYSTEM SIGNS			
	A35RPS	Remote Pull Station, 3'x5'	\$3.75
	A35FSA	Fire System to be Activated, 3"x5"	\$3.75
	A24F	Fryer, 2"x4"	\$3.00
	A24G	Griddle, 2"x4"	\$3.00
	A24H1	Hood #1, 2"x4"	\$3.00
	A24H2	Hood #2, 2"x4"	\$3.00
	A24H3	Hood #3, 2"x4"	\$3.00
	A24H4	Hood #4, 2"x4"	\$3.00
	A25CEF	"Caution Exhaust Fan Must Be Turned On Before Turning On Cooking Appliances" Sign, 2"x5", Adhesive Backed Aluminum	\$1.10

FIRST AID SIGNS

	VFAK1	"First Aid Kit Inside", 3-1/2"x5"	\$0.50
	VFAS1	"First Aid Station Arrow", 8"x11-1/4"	\$1.00
	VEEWI	"Emergency Eye Wash Inside" Sign	\$1.75
	FASRP	"First Aid Station" Plastic Sign, 10"X14"	\$3.00

FIRE EXTINGUISHERS

ANSUL SENTRY FIRE EXTINGUISHERS





Drop shipped to you from one of Ansul's five strategically located warehouses



Foray ABC

Foray ABC				
	Part Number	Description	0-100	100+
	438735	2-1/2 Lb. 1A10BC (A02VB)	\$29.37	\$27.15
	442235	5 Lb. 2A10BC (A05)	\$36.21	\$34.40
	442236	5 Lb. 2A10BC w/Vehicle Bracket (A05VB) - (98/Pallett)	\$38.32	\$36.41
	442257	5 Lb. ABC 3A40BC (AA05) (98/Pallett)	\$36.21	\$34.40
	442258	5 Lb. ABC 3A40BC w/Vehicle Bracket (AA05VB) – (98/Pallett)	\$38.31	\$36.40

FIRE EXTINGUISHERS



	Part Number	Description	0-100	100+
	436500	10 Lb. ABC 4A60BC (AA10S) (63/Pallet)	\$56.94	\$54.10
	434747	20 Lb. ABC 20A120BC (AA20) (48/Pallet)	\$106.27	\$100.96

K-Guard				
	434909	K-Guard Kitchen Ext. (K01-2) (30/Pallet)	\$166.90	\$158.56

Purple K				
	429008	5 Lb. 60BC (PK05) (98/Pallet)	\$46.75	\$43.15
	436494	10 Lb. 80BC (PK10) (72/Pallet)	\$72.25	\$66.69
	429011	20 Lb. 120BC (PK20) (48/Pallet)	\$116.17	\$107.23

FIRE EXTINGUISHERS



Plus 50C

	Part Number	Description	0-100	100+
	429014	5 Lb. 40BC (CO5) (98/Pallet)	\$40.60	\$37.47
	436497	10 Lb. 40BC (C10) (72/Pallet)	\$69.03	\$63.71
	429017	20 Lb. 80BC (C20) (48/Pallet)	\$107.92	\$99.61



Water

	430847	2-1/2 Gallon Water 2-A (W02-1) (90/Pallet)	\$116.69	\$107.70
--	--------	---	-----------------	-----------------





Clean Guard / FE36

	429107	2-1/2 Lb. ABC (FE02VB) (80/Pallet)	\$113.09	\$105.76
	429020	5 Lb. 5BC (FE05) (80/Pallet)	\$170.52	\$159.44
	429021	9 Lb. 1A10BC (FE09) (40/Pallet)	\$346.81	\$324.28

FIRE EXTINGUISHERS

	Part Number	Description	0-100	100+
	429022	13 Lb. 2A10BC (FE13) (40/Pallet)	\$570.28	\$533.24
	432893	13 Lb. 2A10BC (FE13NM) (40/Pallet)	\$575.44	\$537.83

Carbon Dioxide (Aluminum)

	431553	5 Lb. 5BC (CD05A) (35/Pallet)	\$123.62	\$114.10
	431554	10 Lb. 10BC (CD10A) (15/Pallet)	\$172.23	\$158.97
	431555	15 Lb. 10BC (CD15A) (15/Pallet)	\$201.39	\$185.89
	431556	20 Lb. 10BC (CD20A) (12/Pallet)	\$248.62	\$229.48

****Freight PAID on orders of 125 or more fire extinguishers!**

****Best Price on 100+ orders!**

FIRE EXTINGUISHERS

AMEREX FIRE EXTINGUISHERS

Drop Shipped to you from Seattle, WA or Los Angeles, CA

Aluminum Valve ABC

(California, Oregon, Washington and Nevada Only)



	Part Number	Description	0-100	100+
	B417T	2.5 Lb. ABC w/Vehicle Bracket	\$28.50	\$26.30
	B500	5 Lb. ABC	\$37.25	\$34.36
	B500T	5 Lb. ABC w/Vehicle Bracket	\$37.95	\$35.00
	B402	5 Lb. ABC	\$37.25	\$34.36
	B402T	5 Lb. ABC w/Vehicle Bracket	\$37.95	\$35.00
	B443	6 Lb. ABC	\$57.25	\$52.85
	B456	10 Lb. ABC	\$56.25	\$51.95
	A411	20 Lb. ABC	\$106.25	\$98.10

Brass Valve ABC

	B424	5 Lb. ABC	\$60.50	\$55.85
	B461	6 Lb. ABC	\$71.90	\$66.35
	B441	10 Lb. ABC	\$72.95	\$67.35
	A423	20 Lb. ABC	\$120.15	\$110.90

Regular Dry Chemical

	A620T	1 Lb. BC w/Vehicle Bracket	\$28.50	\$26.30
	B403T	2-1/2 Lb. BC w/Vehicle Bracket	\$29.60	\$27.35
	B409T	5 Lb. BC w/Vehicle Bracket	\$41.20	\$38.05
	B453	5-1/2 Lb. BC	\$42.30	\$39.05
	B457	10 Lb. BC	\$62.45	\$57.65
	A412	20 Lb. BC	\$106.00	\$97.85
	B462	6 Lb. BC	\$59.90	\$55.30
	B447	10 Lb. BC	\$75.80	\$69.95
	B408	20 Lb. BC	\$116.40	\$107.45

FIRE EXTINGUISHERS

Aluminum Valve Purple K

	Part Number	Description	0-100	100+
	B410T	2-1/2 Lb. Purple K w/Vehicle Bracket	\$36.75	\$33.95
	B479T	5 Lb. Purple K w/Vehicle Bracket	\$53.30	\$49.20
	A413	20 Lb. Purple K w/Vehicle Bracket	\$129.35	\$119.40

Brass Valve Purple K

	B460	10 Lb. Purple K	\$86.25	\$79.65
	A415	20 Lb. Purple K	\$139.20	\$128.50

Water, Water Mist & Wet Chemical

	A240	2.5 Gallon Pressure Water	\$94.05	\$86.80
	B270	1.75 Gallon Water Mist	\$129.55	\$119.60
	B272	2.5 Gallon Water Mist	\$142.85	\$131.90
	B260	6 Liter Wet Chemical	\$152.60	\$140.85
	B262	2.5 Gallon Wet Chemical	\$181.60	\$167.65

Halotron 1

	A384T	1.4 Lb. Halotron w/Vehicle Bracket	\$84.60	\$78.10
	B385TS	2.5 Lb. Halotron w/Vehicle Bracket	\$99.80	\$92.15
	B386T	5 Lb. Halotron w/Vehicle Bracket	\$161.15	\$148.75
	B394TS	5.5 Lb. Halotron	\$216.30	\$196.90
	A397	11 Lb. Halotron	\$333.85	\$308.15
	A398	15.5 Lb. Halotron	\$481.70	\$444.65

Halon 1211

	A344T	1.25 Lb. BCF	\$129.45	\$119.50
	C352TS	2.5 Lb. BCF	\$158.30	\$146.10
	C354TS	3 Lb. BCF	\$180.50	\$166.65
	B355T	5 Lb. BCF	\$206.05	\$190.20
	B369	9 Lb. BCF	\$359.55	\$331.90
	B371	13 Lb. BCF	\$490.95	\$453.15
	B361	17 Lb. BCF	\$623.45	\$575.50



FIRE EXTINGUISHERS

	Part Number	Description	0-100	100+
Carbon Dioxide				
	A322	5 Lb. Carbon Dioxide Swivel Horn	\$130.60	\$120.55
	A330	10 Lb. Carbon Dioxide	\$191.85	\$177.10
	A331	15 Lb. Carbon Dioxide	\$232.25	\$214.40
	A332	20 Lb. Carbon Dioxide	\$282.10	\$260.40
**Freight PAID on orders of 125 or more fire extinguishers! **Best Price on 100+ orders!				

BADGER FIRE EXTINGUISHERS

Drop Shipped to you from Badger's warehouse in North Carolina

Aluminum Valve ABC				
	22430	2-1/2 Lb. ABC	\$30.60	\$28.25
	22435	5 Lb. ABC Wall Hook	\$38.25	\$35.31
	22486	5 Lb. ABC Vehicle Bracket	\$41.90	\$38.70
	22603	10 Lb. ABC Wall Hook	\$63.20	\$58.35
	22682	20 Lb. ABC Wall Hook	\$111.64	\$103.06

Brass Valve ABC				
	23384	2-1/2 Lb. ABC	\$35.82	\$33.10
	23390	5 Lb. ABC Wall Hook	\$45.25	\$41.75
	23463	5 Lb. ABC Vehicle Bracket	\$47.20	\$43.56
	23396	10 Lb. ABC Wall Hook	\$66.10	\$61.00
	23497	20 Lb. ABC Wall Hook	\$116.77	\$107.79
	21006158	10Lb. ABC High Flow	\$95.98	\$88.60
	21006160	20Lb. ABC High Flow	\$142.46	\$131.50

FIRE EXTINGUISHERS

	Part Number	Description	0-100	100+
Water and K Class				
	16888	2-1/2 Gallon Water	\$95.75	\$88.40
	25064	K-Class	\$154.07	\$142.22

Carbon Dioxide				
	21111	5 Lb. Carbon Dioxide	\$123.87	\$114.34
	21106	10 Lb. Carbon Dioxide	\$174.17	\$160.77
	21103	15 Lb. Carbon Dioxide	\$210.63	\$194.43
	21096	20 Lb. Carbon Dioxide	\$256.55	\$236.81

Halotron				
	24563	2-1/2 Lb. Halotron	\$93.75	\$86.55
	24567	5 Lb. Halotron	\$156.85	\$144.78
	23082	11 Lb. Halotron	\$324.20	\$299.25
	23097	15-1/2 Lb. Halotron	\$471.15	\$434.90

**Freight PAID on orders of 125 or more fire extinguishers! **Best Price on 100+ orders!

BUCKEYE FIRE EXTINGUISHERS



ABC				
	13315	2.5 Lb. ABC w/Vehicle Bracket	\$26.40	\$24.36
	10914	5 Lb. ABC	\$31.95	\$29.50
	25614	5 lb. ABC w/Vehicle Bracket	\$34.75	\$32.06
	11340	10 Lb. ABC	\$48.62	\$44.89
	12120	20 Lb. ABC	\$90.28	\$83.35

FIRE EXTINGUISHERS

	Part Number	Description	0-100	100+
Carbon Dioxide				
	45100	5 Lb. CO2	\$118.06	\$109.20
	45600	10 Lb. CO2	\$170.86	\$158.02
	46100	15 Lb. CO2	\$204.17	\$188.85
	46600	20 Lb. CO2	\$259.58	\$240.11

K Class				
	50006	6 Liter Class K	\$131.95	\$121.80



Mini-Guard Automatic Fire Extinguishers				Ea.
	80251	2.5 Lb. ABC 14.25"x3.375", 120CF, Horizontal	\$214.87	
	80250	2.5 Lb. ABC 15.25"x3.375", 120CF, Vertical	\$173.20	
	80521	5 Lb. ABC 17.25"x4.25", 180CF, Horizontal	\$288.34	
	80501	5 Lb. ABC 17.25"x4.25" 180CF, Vertical	\$246.67	
	81021	10 Lb. ABC 20.875"x5.125", 1300CF, Horizontal	\$385.84	
	81001	10 Lb. ABC 17.625"x6", 1300CF, Vertical	\$344.17	
	82021	20 Lb. ABC 21.875"x7.5", 2184CF, Horizontal	\$501.53	
	82001	20 Lb. ABC 21.875"x7.5", 2184CF, Vertical	\$459.87	
	87105	18 Lb. Halotron I, 17.875"x7", 500CF, Horizontal	\$796.05	
	87100	18 Lb. Halotron I, 17.875" x 7", 500CF, Vertical	\$754.38	
87205	25 Lb. Halotron I, 21.875"x7.5", 700CF, Horizontal	\$976.95		
87200	25 Lb. Halotron I, 21.875"x7.5", 700CF, Vertical	\$935.28		

Maximum Local Application Height Above Hazard is 4 Feet For All Models



WET & DRY CHEMICALS

WET CHEMICALS



****Wet & Dry Agents NOT included in free freight policy**

Amerex	Part Number	Description	Price Ea.
	A530	6 Liter Wet Chemical, Liquid Recharge (B260), Each	\$46.75
	670-2	1.8 Gal De-ionized Water, Amerex, Each	\$11.15
	671-2	2.5 Gal De-ionized Water, Amerex, Each	\$12.60
	A502	AFFF Recharge for 250, 254 & 252	\$14.75
	A534	2 Gallon AFFF 3X6 (630)	\$135.30
	A506	Loaded Stream Anti Freeze (240)	\$53.60
	A660	1-1/2 Gallon Wet Chemical, Liquid (B262)	\$52.40
	16924	2.75 Gal KP Recharge Model 547	\$68.69
	A12866	3.75 Gal KP Recharge Model 544	\$98.69
	A17450	4.75 Gal KP Recharge Model 656	\$111.61
	A15416	6.14 Gal KP Recharge Model 664	\$157.37

Ansul

	79656	Flushing Concentrate	\$15.50
	79694	1-1/2 Gallon K-Guard Recharge (Ansulex)	\$81.82
	79372	3 Gallon Ansulex	\$139.30
	430182	6 Liter PRX	\$49.75

WET & DRY CHEMICALS

Badger			
	423320	5 Gallon PRX	\$160.50
	25092	6L Wet Chemical, For Badger K, Each	\$44.75
	97257	2-1/2 Gallon Karbaloy	109.80
	RG96991	4 Gallon Karbaloy	\$149.95
	B120033	6 Gallon Karbaloy	\$193.65

PyroChem			
	551188	3 Gallon Kitchen Knight Agent	\$120.15
	553176	1.6L Kitchen Knight Agent	\$73.25

DRY CHEMICALS

ANSUL			
	9335	40Lb. Pail, Purple K (36/Pallett)	Call for Pricing
	9336	50 Lb. Pail, Plus 50C (36/Pallett)	
	53080	45 Lb. Pail, Foray (ABC) (36/Pallett)	
	415788	45 Lb. Pail, Foray AA (3A40BC) (36/Pallett)	

AMEREX			
	A540-4	50 Lb. CTN, ABC (4x10)	Call for Pricing
	A550	50 Lb. Pail, ABC	
	A541	40 Lb. CTN, BC	
	A512	50 Lb. Pail, BC	
	A515	50 Lb. Pail, Purple K	
	A555	50 Lb. Pail, ABC	

BADGER <i>**Wet & Dry Agents NOT included in free freight policy</i>			
	18905	50 Lb. Pail, ABC	Call for Pricing
	18903	50 Lb. Pail, BC	
	18907	50 Lb. Pail, Purple K	

RECLAIMED CHEMICALS			
	R-POWDER	ABC & BC Reclaimed Chemicals	\$28.50 Call for Availability

FIRE SYSTEM PARTS & ACCESSORIES

GENUINE GLOBE FUSIBLE LINKS

Globe Model ML *Load Range 10lbs.-40lbs.*

	Part Number	Description	Price Ea.
	G165ML	165° Model ML	\$2.84
	G212ML	212° Model ML	\$2.84
	G280ML	280° Model ML	\$2.84
	G360ML	360° Model ML	\$2.84
	G450ML	450° Model ML	\$2.84
	G500ML	500° Model ML	\$4.88

Globe Model A *Load Range 3lbs.-45lbs.*

	G360A	360° Model A	\$2.50
	G450A	450° Model A	\$2.71





Globe Model K (Ansul) *Load Range 3lbs.-50lbs.*

	G165K	165° Model K (Ansul)	\$2.32
	G212K	212° Model K (Ansul)	\$2.32
	G280K	280° Model K (Ansul)	\$2.32
	G360K	360° Model K (Ansul)	\$2.32
	G450K	450° Model K (Ansul)	\$2.32





Ansul HL Link

	439227	165° Model HL (Ansul)	\$2.89
	439228	212° Model HL (Ansul)	\$2.89
	439229	280° Model HL (Ansul)	\$2.89
	439230	360° Model HL (Ansul)	\$2.89
	439231	450° Model HL (Ansul)	\$2.89
	439232	500° Model HL (Ansul)	\$4.78

FIRE SYSTEM PARTS & ACCESSORIES

Colored Links (Ansul)			
	439085	165° Black (Ansul)	\$2.34
	439086	212° White (Ansul)	\$2.34
	439087	280° Blue (Ansul)	\$2.34
	439088	360° Red (Ansul)	\$2.34
	439089	450° Green (Ansul)	\$2.34

System Service Reports			
	RHSR	Rangehood Fire System Service Report 3-Part Form, Package of 100	\$13.25
	ISSR	Industrial Fire System Service Report 3-Part Form, Package of 25	\$3.50
	ORVSR	Vehicle Fire System Service Report 3-Part Form, Package of 25	\$3.50
	Custom System Service Reports		
	CSSR	<i>Customize any one of the above Service Reports – Minimum Order 250</i>	
		250 – 499	\$0.75 ea
	500 – 999	\$0.70 ea	
	1000+	\$0.60 ea	

ANSUL R-102 SYSTEM PARTS			
Nozzles & Nozzle Accessories			
	439836	1F Nozzle	\$25.75
	439837	½ N Nozzle	\$25.95
	439838	1 N Nozzle	\$23.40
	439839	1W Nozzle	\$22.45



FIRE SYSTEM PARTS & ACCESSORIES



	Part Number	Description	Price Ea.
	439840	2W Nozzle	\$22.45
	439841	3N Nozzle	\$27.90
	439842	230 Nozzle	\$22.70
	439843	245 Nozzle	\$22.70
	439844	260 Nozzle	\$23.30
	439845	290 Nozzle	\$23.30
	439846	2120 Nozzle	\$27.10
	423572	Nozzle Swivel Adapter	\$14.25
	77695	Ansul-Style Rubber Blow Off Cap, Non UL Listed	\$0.90
	77695A	Genuine Ansul Rubber Blow Off Cap	\$1.40
	433208	Genuine Ansul Metal Blow Off Cap w/O-Ring	\$8.65
	ASBOC	Ansul-Style Metal Blow Off Cap w/O-Ring	\$4.60
	439861	Genuine Ansul Metal Blow Off Cap – New Style	\$8.85
	AMNS	Ansul-Style Metal Blow Off Cap – New Style	\$4.60
	439848	Genuine Ansul O-Ring for new style cap	\$1.10

FIRE SYSTEM PARTS & ACCESSORIES

	Part Number	Description	Price Ea.
Series Detectors			
	435547	Series Detector w/New Stainless Scissor	\$23.25
	435545	Scissor Linkage	\$10.90

Cocking Lever			
	441041	Ansul Cocking Lever	\$34.00
	441042	Ansul Short Cocking Lever	\$30.70
	14985	Ansul Lock Bar	\$9.75





Cartridges, Ansul ** Cartridges NOT included in free freight policy			
	17492	Carbon Dioxide, 101-20	\$79.25
	15851	Carbon Dioxide, 101-30	\$99.00
	7032	Nitrogen LT20-R	\$73.50
	5373	Nitrogen LT30-R	\$79.85
	73022	Nitrogen R-102 Double Tank	\$244.10
	417911	Bursting Disc	\$5.30
	68800	Vent Plug	\$13.00

Miscellaneous Parts			
	418511	Hose & Grommet Kit	\$26.50
	79007	Hose Only	\$15.75
	434618	Ansul Remote Pull	\$44.00
	24915	Ansul Break Rod (10/pk - \$7.00)	\$0.75

FIRE SYSTEM PARTS & ACCESSORIES



	Part Number	Description	Price Ea.
	79318	Ansul R-102 Replacement Regulator	\$128.00
	55598	Ansul Gas Valve, 3/4"	\$216.00
	55601	Ansul Gas Valve, 1"	\$232.00
	55604	Ansul Gas Valve, 1-1/4"	\$245.00
	55607	Ansul Gas Valve, 1-1/2"	\$259.00
	55610	Ansul Gas Valve, 2"	\$272.00
	25937	Gas Valve, 2-1/2"	\$611.00
	25938	Gas Valve, 3"	\$672.00





Micro Switches			
	423878	Electric SPDT	\$17.34
	423879	Electric DPDT	\$33.70
	423880	Electric 3PDT	\$39.00
	423881	Electric 4PDT	\$69.30
	428311	Alarm Initiating Switch	\$22.60

RANGEGUARD SYSTEM PARTS			
Nozzles			
	KR97054	RangeGuard Style Foil Nozzle Seals (10/pk - \$16.50) (Sold by each)	\$1.65
	9197054	Genuine RangeGuard Foil Nozzle Seals (10/pk - \$33.50) (Sold by each)	\$3.38
	B120016	ADP Nozzle	\$27.95
	B120017	F Nozzle	\$27.95
	B120018	GRW Nozzle	\$27.95
	B120019	R Nozzle	\$27.95
	B120020	DM Nozzle	\$31.12
	B120023	LPF Nozzle	\$31.12
	B120025	LPR Nozzle	\$37.50
	9197290	Nozzle Disc Cap	\$1.95

FIRE SYSTEM PARTS & ACCESSORIES

	Part Number	Description	Price Ea.
Gas Valves			
	B120071	3/4" Mechanical Gas Valve	\$154.66
	B120072	1" Mechanical Gas Valve	\$165.28
	B120073	1-1/4" Mechanical Gas Valve	\$187.71
	B120074	1-1/2" Mechanical Gas Valve	\$204.25
	B120075	2" Mechanical Gas Valve	\$216.65





System Trim			
	B875572	Mechanical Remote Manual Release	\$49.68
	120064	Standard Detector Kit w/Bracket (2) "S" Hooks & (2) Cable Crimps	\$10.76
	844908	Discharge Adapter Kit	\$18.31
	B120043	Nitrogen Cartridge for Universal Control Head	\$23.05
	06-235557-001	12 Gram Carbon Dioxide Cartridge for A+ Control Head	\$5.70
	12GRCO2	12 Gram Carbon Dioxide Cartridge, Generic	\$4.30
	B120042	System Valve Actuator	\$62.00
	B120067	System Valve Rebuild Kit	\$56.67
	B120045	High Pressure Hose	\$24.85
	9196984	Vent Plug (Wet Chem only)	\$10.65

AMEREX SYSTEM PARTS			
	A12738	Amerex KP Lock Out Tool	\$47.23
	A10134	Amerex KP Manual Actuator	\$104.60
	A9902	Amerex KP Recharge Adapter	\$35.64
	A13341	Amerex MRM Cocking Tool	\$52.23
	TL	Amerex Test Link	\$0.40
	A12856	10 cubic inch N2 Cylinder w/Gauge	\$102.80
	16924	2.75 Gal KP Recharge Model 547	\$68.69



FIRE SYSTEM PARTS & ACCESSORIES

	Part Number	Description	Price Ea.
	A12866	3.75 Gal KP Recharge Model 544	\$98.69
	A17450	4.75 Gal KP Recharge Model 656	\$111.60
	A15416	6.14 Gal KP Recharge Model 664	\$157.37
	16557	25ft KP Detection Tubing	\$125.00
	A16551	50ft KP Detection Tubing	\$237.50
	A16579	100ft KP Detection Tubing	\$472.24
	A12508	Detector (includes bracket, linkage & conduit fittings)	\$10.98
	A16501	Tubing Clip	\$1.05
	A13729	Nozzle – Fryer, Griddle, 2 Flow Points	\$17.95
	A11982	Nozzle – Appliance, Plenum – 1 Flow Point	\$17.95
	A11983	Nozzle – Solid Fuel Charbroiler/Duct – 1.5 Flow Points	\$17.95
	A11984	Nozzle – Upright Charbroiler – 0.5 Flow Points	\$17.95
	A16416	Nozzle – Duct – 1 Flow Point	\$17.95
	A14178	Nozzle–ZD Appl. & 4 Burner Range/4' Griddle–2 Flow Point	\$25.70
	A12524	Micro Switch SPDT	\$17.25
	A12504	Amerex Metal Blow Off Cap	\$10.98
	A12334	Rubber Blow Off Cap	\$2.30
	A13600	Amerex KP 3.75 Valve Stem	\$13.55
	A10134	Amerex KP600 Recharge Tool / T-Handle	\$104.60
	A12855	Amerex KP2.75, 3.75 and 4.75 Recharge Tool/T-Handle	\$60.07
	A10095	Amerex Vehicle System Valve Stem	\$15.00
	5240/OR29	Amerex Collar O-Ring: Fits KP2.75, 3.75, 4.75 & 50Lb Stored Pressure	\$1.05
	A5239	Amerex Collar Quad Ring: Fits KP600, IS System Tanks & 125/150Lb	\$3.00

PYRO-CHEM SYSTEM PARTS

Kitchen Knight			
	551026	Pyro-Chem Nozzle, 1L	\$28.27
	551038	Pyro-Chem Nozzle, 2D	\$28.27
	551028	Pyro-Chem Nozzle, 2H	\$28.27
	551029	Pyro-Chem Nozzle, 1H	\$28.27

FIRE SYSTEM PARTS & ACCESSORIES

	Part Number	Description	Price Ea.
	550016	Genuine Pyro-Chem Rubber Blow Off Cap	\$2.30
	551528	Genuine Pyro-Chem Steel Blow Off Caps	\$4.00
	551530	Genuine Pyro-Chem O-Rings, Wet Nozzle	\$1.25
	550698	Wet Valve Rebuild Kit	\$30.00
	551240	Wet Recharge Adapter Kit	\$37.25

Kitchen Knight & Monarch

	550876	Fusible Link Hanger	\$4.00
	551059	16 Gram Cartridge – Genuine Pyro-Chem	\$11.90
	16GRCO2	16 Gram Carbon Dioxide Cartridge - Generic	\$4.56
	550054	MB-15 Bracket	\$55.21
	550077	Alarm Initiating Switch Assembly	\$16.40
	551154	One Switch Assembly	\$17.90
	551155	Two Switch Assembly	\$35.07
	552173	Micro Switch Ext Unit	\$12.00
	550053	MB-1 Bracket	\$61.51
	550853	Control Head Mounting Bracket	\$31.30

Monarch

	550324	MBU-8 Bracket	\$36.81
	550383	MF-U10	\$42.50
	550638	MB-U12 Assembly	\$52.45
	551651	NV-UF Nozzle	\$49.31
	551074	Remote Pull Station	\$51.75
	551101	N-DLT Nozzle	\$49.31
	551653	NV-D/P2 Nozzle	\$49.31
	552175	NV-SW Nozzle	\$49.31
	551100	N-PLU Nozzle	\$49.31
	551099	N-OTF Nozzle	\$49.31
	551098	N-SCR Nozzle	\$49.31

FIRE SYSTEM PARTS & ACCESSORIES

UL LISTED PIPE SEALS

	Part Number	Description	Price Ea.
	HS1	3/8" Pipe, 7/8" Hole	\$8.25
	HS38	3/8" Pipe, 1-1/8" Hole	\$9.00
	HS5	1/4" Pipe, 7/8" Hole	\$7.80
	XHS2	1/2" Pipe	\$8.70
	HS3	3/4" Pipe	\$12.95
	HS4	1" Pipe	\$19.75

UL LISTED COMPRESSION SEALS

	CS8	5/8" Tube, 3/8" Pipe	\$10.75
	CS9	1/2" EMT	\$10.75
	CS10	1/2" Pipe	\$11.75
	CS11	3/4" Pipe	\$16.50



UL LISTED CORNER PULLEY SEALS

	CPS12	Fits Brooks CP5	\$8.25
	CPS13	Fits Ansul, Badger, Kidde and Heiser	\$8.25





UL LISTED HOOD PATCH SEALS

	HPS1	3/4" to 7/8"	\$7.00
	HPS2	7/8" to 1"	\$7.00
	HPS3	1-1/8" to 1-5/16"	\$7.25
	HPS4	1-3/8" to 1-9/16"	\$12.00
	HPS5	1-5/8" to 1-7/8"	\$17.75

MISCELLANEOUS FIRE SYSTEM PARTS



	423251	Corner Pulley	\$4.00
	SHK	S-Hooks (100/Bag)	\$10.85
	16CRIMP	1/16" Cable Crimps (100/Bag)	\$10.08
	T520	1/2" x 520" Teflon Tape	\$0.75
	316H	Cutter	\$20.00
	1404	1/4" Quik-Fastener w/ 1/8" Pilot (25/pk)	\$22.16

FIRE SYSTEM PARTS & ACCESSORIES

	Part Number	Description	Price Ea.
	116H	Crimper	\$23.00
	576	Stop Sleeve, 1/16" (100/case)	\$19.74
	BDA	Burst Disc Assembly	\$2.90
	PG1	Surface Mount Pull Station Guard	\$4.25
	PG2	Recessed Remote Pull Station Guard	\$10.25
	551265	Laser Aiming Device	\$140.00
	431186	Laser Aiming Device Bracket – Old Style Nozzle	\$23.75
	439876	Laser Aiming Device Bracket – New Style Nozzle	\$23.75
	AA112	Hitorquer Nutcert Tool	\$75.00
	AAT202-420	Hitorquer Mandrel for 1/4"-20 Nutcerts	\$33.00
	ALS4-420-165B	1/4"-20 Nutcerts	\$0.38
	79653	Genuine Ansul 1/16" SS Wire – 500 Feet	\$99.75
	15821	Genuine Ansul 1/16" SS Wire – 50 Feet	\$24.50

CABINETS

LOCKS

	Part Number	Description	Price Ea.
	1635AB	Abus Lock	\$3.00
	PLB	Brass Padlock	\$3.75

CATO CHIEF EXTINGUISHER CABINETS





Features: A body and frame of injection molded high-impact crystal polystyrene with a .11 wall thickness and ultraviolet inhibitors. Each cabinet also includes a chromium-plated brass cylinder lock and key with weatherproof lock cover. Breaker bar included.

	105-5WWC-0	5 Lb. White Cabinet, 19"x8"x6-3/8"	\$32.25
	105-5RRC-0	5 Lb. Red Cabinet, 19"x8"x6-3/8"	\$32.95
	105-10WWC-0	10 Lb. White Cabinet, 23"x9"x7"	\$36.05
	105-10RRC-0	10 Lb. Red Cabinet 23"x9"x7"	\$35.95
	105-20RRC-0	20 Lb. Red Cabinet 11" x 8" x 30"	\$59.30
	12075	20 Lb. Replacement Panel	\$11.85
	10575	5 Lb. Clear Front Replacement Panel, Fits 105-5 Models	\$6.95
	11075C	10 Lb. Clear Front Replacement Panel, Fits 105-10 Models	\$8.50

****Cabinets are not included in Free Freight – Cabinets & Covers subject to availability.**

WEST PLASTIC EXTINGUISHER CABINETS

Features: An economically-minded alternative for your cabinetry needs. This plastic surface-mounted cabinet features a pre-scored clear acrylic panel and outer bezel with a theft-deterrent cylinder lock.

	F1133RK	5 Lb. Red Cabinet, 19"x8"x6-3/8"	\$22.75
	F1133WK	5 Lb. White Cabinet, 19"x8"x6-3/8"	\$22.75
	F11322	5 Lb. Clear Acrylic Replacement Panel	\$5.00
	F11321	Stainless Steel Breaker Bar Assembly	\$2.80

CABINETS

	Part Number	Description	Price Ea.
	10011R	Red Plastic Breaker Hammer Assembly	\$5.50

****Cabinets are not included in Free Freight – Cabinets & Covers subject to availability.**

JL FIRE EXTINGUISHER CABINETS

Surface Mounted

EconomyLine – Interior

Features: A gray hammer-tone basic steel cabinet with breaker bar and slide-in clear acrylic front panel held in by a retainer clip. Pre-drilled holes for padlock (sold separately).

	5013N20	5 Lb. Hammer-tone, 8.5"W x 18"H x 5-1/2"D	\$30.30
	5113N20	10 Lb. Hammer-tone, 9-1/8"W x 24"H x 5-1/2"D	\$40.33
	5213N20	20 Lb. Hammer-tone, 10-1/8"W x 28"H x 1-1/4"D	\$57.86

Classic Series –Interior/Exterior

Features: A white powder-coated cabinet with galvanized steel construction for greater durability, slide-in clear acrylic front panel, breaker bar, and cylinder lock for theft deterrence.

	99G	5 Lb. White, 8.5"W x 19.81"H x 6.25"D	\$41.50
	999G	10 Lb. White, 9.5"W x 25.75"H x 6.25"D	\$46.95
	104G	20 Lb. White, 10.5"W x 29.75"H x 8.25"D	\$63.35

Corner Vu – Interior

Features: A white powder-coated steel cabinet fits snugly into the corner. Hinged door with pull handle, zinc-plated roller latch, and clear acrylic window.

	8913F10	5 Lb. White, 15-3/4"W x 18"H x 8-1/8"D	\$62.73
	8813F10	10 Lb. White, 15-3/4"W x 24"H x 8/1/8"D	\$64.50

CABINETS

SMB (Surface Mounted Bubble) Series – Interior

	Part Number	Description	Price Ea.
--	-------------	-------------	-----------

Features: A faux semi-recessed cabinet made of cold rolled steel in your choice of seven finishes, flush cabinet doors with a zinc-plated handle and roller catch and an acrylic bubble that offers 180degree visibility. The cabinet and bubble combined offer a 5-1/2" tub depth. **Note that extinguishers must be mounted inside the cabinet as there is not a shelf to sit on.**



	SMB-W25	10 Lb. White, 13-15/16"W x 27-7/16"H x 5-1/2"D	\$88.93
	SMB-GH25	10 Lb. Gray, 13-15/16"W x 27-7/16"H x 5-1/2"D	\$88.93
	SMB-R25	10 Lb. Red, 13-15/16"W x 27-7/16"H x 5-1/2"D	\$88.93
	SMB-BK25	10 Lb. Black, 13-15/16"W x 27-7/16"H x 5-1/2"D	\$88.93
	SMB-BRA25	10 Lb. Brass, 13-15/16"W x 27-7/16"H x 5-1/2"D	\$95.93
	SMB-B25	10 Lb. Bronze, 13-15/16"W x 27-7/16"H x 5-1/2"D	\$95.93
	SMB-SI25	10 Lb. Silver, 13-15/16"W x 27-7/16"H x 5-1/2"D	\$95.93

Decorline Series Surface Mount – Interior/Exterior

Features: A white powder-coated steel cabinet. The door features a clear acrylic window with a zinc-plated pull handle and optional cylinder lock for theft deterrence.



	5019F20	5 Lb White w/Door 8"W x 17-7/8"H x 5-5/8"D	\$48.15
	5019G20	5 Lb White w/Door & Lock 8"W x 17-7/8"H x 5-5/8"D	\$53.20
	5119F20	10 Lb. White w/Door, 9"W x 23-7/8"H x 5-5/8"D	\$55.70
	5119G20	10 Lb. White w/Door & Lock, 9"W x 23-7/8"H x 5-5/8"D	\$66.70

Semi-Recessed

Decorline Series Semi-Recessed – Interior/Exterior

Features: A white powder-coated steel cabinet. Available with either a hinged door with 3" trim or a slide-in clear acrylic panel with a retainer clip and 2.5" trim. The door features a clear acrylic window with a zinc-plated pull handle and optional cylinder lock for theft deterrence.



	501AN20	5 Lb. White w/Acrylic Panel, 8-1/8"W x 18"H x 5-1/2"D	\$51.85
		2.5" Trim, Wall Opening: 9"W x 19"H x 4"D	
	511AN20	10 Lb. White w/Acrylic Panel, 9-1/8"W x 24"H x 5-1/2"D	\$56.77
		2.5" Trim, Wall Opening: 10"W x 25"H x 4"D	
	521AN20	20 Lb. White w/Acrylic Panel, 10-1/8"W x 28"Hx8-1/4"D	\$69.70
		2.5" Trim, Wall Opening: 11"Wx29"Hx6"D	
	5017F20	5 Lb. White w/Door, 8"Wx17-7/8"Hx5x5/8"D	\$58.15
		3" Trim, Wall Opening: 9"Wx19"Hx3-1/4"D	

CABINETS

	Part Number	Description	Price Ea.
	5117F20	10 Lb. White w/Door, 9"Wx23-7/8"Hx5-5/8"D	\$65.30
		3" Trim, Wall Opening: 10"Wx25"Hx3-1/4"D	
	5017G20	5 Lb. White w/Door & Lock, 8"Wx17-7/8"Hx5-5/8"D	\$59.65
		3" Trim, Wall Opening, 9"Wx19"Hx3-1/4"D	
	5117G20	10 Lb. White w/Door & Lock, 9"Wx23-7/8"Hx5-5/8"D	\$69.70
		3" Trim, Wall Opening: 10"Wx25"Hx3-1/4"D	

STRIKE FIRST APEX SEMI-RECESSED CABINETS

Features: A non-rated semi-recessed extinguisher cabinet made of 16 gauge cold rolled steel welded to 22 gauge cold rolled steel tubs. The doors have a Vertical Duo style thin window with a pull handle.

	SR5VD	5 Lb. White, 8"Wx17"Hx5"D, DOES NOT FIT ANSUL	\$70.50
		1" Trim, Wall Opening: 8-1/4"Wx17-1/4"Hx4"D	
	SR10VD	10 Lb. White, 9-1/2"Wx24"Hx6"D	\$104.62
		2.5" Trim, Wall Opening: 9-3/4"Wx24-1/4"Hx3-1/2"D	

CABINETS TO FIT ANY JOB SPECIFICATION!

INCLUDES SAMSON, JL, POTTER ROMEN & LARSON CABINETS Call for Quote

REPLACEMENT GLASS

JL Replacement Acrylic & Breaker Bars

	1122	Replacement Acrylic for 99G and 5013N20	\$5.00
	1123	Replacement Acrylic for 999G and 5133N20	\$6.00
	1124	Replacement Acrylic for 104G	\$7.00
	HCM	Breaker Bar with Magnet	\$3.95
	BB5F25	Replacement Acrylic Bubbles for SMB Cabinets, Clear	\$18.50
	BB5F26	Replacement Acrylic Bubbles for SMB Cabinets, Red	\$37.25
	BB5F27	Replacement Acrylic Bubbles for SMB Cabinets, Bronze	\$42.75

Replacement Plexi Glass



	CLASSIC100RA	Replacement Glass, 99G	\$10.50
	C999RA	Replacement Acrylic for Cabinet, 999G	\$12.50

CABINETS



	Part Number	Description	Price Ea.
Bubbles			
	BXS	Extra Small Fire Extinguisher Cabinet Bubble 21-1/2 x 6-3/4 x 4	Call for Pricing
	BS	Small Fire Extinguisher Cabinet Bubble 22-1/4 x 8-1/2 x 4	
	BL	Large Fire Extinguisher Cabinet Bubble 28-1/2 x 12 x 5	
	BVPS	Small Vandal Proof Polycarbonate Bubble 22-1/4 x 8-1/2 x 4	
	BVPL	Large Vandal Proof Polycarbonate Bubble 28-1/2 x 12 x 5	

FSP INDUSTRIAL PRODUCTS EXTINGUISHER CABINETS

Cabinets come standard with the viewing window. 003 Break glass are a standard feature with key lock units.

	CFE250R	5.5 Lb., 10 13/16"W x 7/18"D x 20 1/4"H	\$68.25
	CFE450R	10 Lb., 12 1/4"W x 12 1/4" D x 26"H	\$104.50
	CFE900R	20 Lb., 12 1/4"W x 12 1/4" D x 31 1/2"H	\$122.20
**Cabinets are not included in Free Freight.			



CABINETS

CABINETS			
	Part Number	Description	Price Ea.
Fire Extinguisher Stand			
	CFESTAND	Portable extinguisher stand. Holds up to 20Lb. extinguisher. 19 1/4"W x 19 1/4"D x 29 1/2"H	\$103.86
Safety Flag			
	SFLAGKIT	Safety Flag Kit includes 4-piece pole, flag, coupling and mount spring. Modular system.	\$66.75

FIRE HOSE & NOZZLES

PIN RACK & REEL HOSE

We can meet any spec of fire hose!

	Part Number	Description	Price Ea.
	RR1550RPN	1-1/2", 500 PSI, 55' Rack & Reel Fire Hose Lightweight pre-folded manufactured to NFPA 1961 and 1962 Standards, FM Approved. Each section comes pre-folded for ease of installation on pin racks. Pressure tested at 500psi.	\$68.00
	RR1575RPN	1-1/2", 500 PSI, 75' Rack & Reel Fire Hose Lightweight pre-folded manufactured to NFPA 1961 and 1962 Standards, FM Approved. Each section comes pre-folded for ease of installation on pin racks. Pressure tested at 500psi.	\$88.00
	RR15100RPN	1-1/2", 500 PSI, 100' Rack & Reel Fire Hose Lightweight pre-folded manufactured to NFPA 1961 and 1962 Standards, FM Approved. Each section comes pre-folded for ease of installation on pin racks. Pressure tested at 500psi.	\$109.50

****Fire Hoses are not included in Free Freight – Fire Hoses are subject to availability.**

HOSE NOZZLES - POLYCARBONATE

	1030NST	1" Combination Stream, Fog Nozzle, Hose Thread	\$10.35
	1030NPSH	1" Combination Stream, Fog Nozzle, Pipe Thread	\$10.35
	1575NST	1-1/2" Combination Stream, Fog Nozzle, Hose Thread	\$10.00
	1575NPSH	1-1/2" Combination Stream, Fog Nozzle, Pipe Thread	\$10.50

PLASTIC CAPS FOR HYDRANTS & STANDPIPES







	AHYW1	3" Hydrant Wrench	\$22.60
	1500	Plastic Cap, 1.5" Thread	\$5.20
	2500	Plastic Cap, 2.5" Thread	\$5.25
	2500U	Plastic Cap, 2.5" Universal Thread	\$5.50
	2502BC	2.5" Plastic Break Cap	\$2.25
	2501AP	2.5" Plastic Adjust-A-Plug	\$2.50
	2502EB/HN	1 Bolt & Hex Nut Set	\$1.45

ALUMINUM, BRASS OR STEEL COUPLERS, ADAPTERS, CAPS & PLUGS

		Multiple Options Available: Call with thread, size and material requirements	Call for Pricing and Availability
---	--	---	--



EMERGENCY LIGHTING

CONTRACTOR GRADE THERMOPLASTIC LED UNITS

	Part Number	Description	Price Ea.
	OX-LED-90	Thermoplastic LED Emergency Lighting Unit	Call for Pricing
	OX-LED-60	Thermoplastic LED Emergency Lighting Unit	
	OX-VLED-1	Thermoplastic Combination LED Exit & LED Lamps, Single Face	
	OX-VLED-U	Thermoplastic Combination LED Exit & LED Lamps, Universal	
	OX-CLED-1	Thermoplastic Combination LED Light Bar Exit, Single Face	
	OX-CLED-U	Thermoplastic Combination LED Light Bar Exit, Universal	
	OX-TEM	Thermoplastic LED Combo Exit	
	OX-NAV-C-6-42	Vandal Resistant, Wet Location LED Combo Exit, 6-Volt, 42 Watts	
	OX-NAV-C-12-45	Vandal Resistant, Wet Location LED Combo Exit, 12-Volt, 45 Watts	

BARRIERS

FSP INDUSTRIAL PRODUCTS SAFETY BARRIERS







	Part Number	Description	Price Ea.
	SEDF	Pedestrian/Traffic/Control Barrier 78 3/4" x 3 1/2" x 47 1/4" (with plastic feet)	\$192.50
	DBDF	Dirt Bag Barrier – Can be stabilized with sand bags, dirt or any other material when water is not available. 45"W x 22 1/2"D x 27 1/2" (without sign) 39 3/8" (with sign)	\$156.00

SAFETY & PERSONAL PROTECTIVE EQUIPMENT

GLOVES

	Part Number	Description	Price Ea.
	N5201-S	NITRILE P/F Multi-purpose 4 Mil Small Blue Gloves, 100/Bx	\$4.72
	N5201-M	NITRILE P/F Multi-purpose 4 Mil Medium Blue Gloves, 100/Bx	\$4.72
	N5201-L	NITRILE P/F Multi-purpose 4 Mil Large Blue Gloves, 100/Bx	\$4.72
	N5201-XL	NITRILE P/F Multi-purpose 4 Mil X-Large Blue Gloves, 100/Bx	\$4.72
	N5201-XXL	NITRILE P/F Multi-purpose 4 Mil 2X-Large Blue Gloves, 100/Bx	\$4.72
	11-6007	ANSELL HyFlex Glove, Size 7 Black	\$2.60
	11-6008	ANSELL HyFlex Glove, Size 8 Black	\$2.60
	11-6009	ANSELL HyFlex Glove, Size 9 Black	\$2.60

SAFETY & PERSONAL PROTECTIVE EQUIPMENT

	Part Number	Description	Price Ea.
	11-60010	ANSELL HyFlex Glove, Size 10 Black	\$2.60
	11-60011	ANSELL HyFlex Glove, Size 11 Black	\$2.60
	BO500B- S	SHOWA Best Hi-Tech Glove Black, Small	\$1.94
	BO500B-M	SHOWA Best Hi-Tech Glove Black, Medium	\$1.94
	BO500B-L	SHOWA Best Hi-Tech Glove Black, Large	\$1.94
	BO500B-XL	SHOWA Best Hi-Tech Glove Black, X-Large	\$1.94
	BO500B-XXL	SHOWA Best Hi-Tech Glove Black, XX-Large	\$1.94

SAFETY & PERSONAL PROTECTIVE EQUIPMENT



VESTS

	Part Number	Description	Price Ea.
	SV2ZO-S	RADIANS Orange Mesh Vest W/Zipper, Small	\$4.68
	SV2ZO-M	RADIANS Orange Mesh Vest W/Zipper, Medium	\$4.68
	SV2ZO-L	RADIANS Orange Mesh Vest W/Zipper, Large	\$4.68
	SV2ZO-XL	RADIANS Orange Mesh Vest W/Zipper, X- Large	\$4.68
	SV2ZO-2XL	RADIANS Orange Mesh Vest W/Zipper, XX-Large	\$4.68
	SV2ZO-3XL	RADIANS Orange Mesh Vest W/Zipper, XXX-Large	\$4.68
	SV2ZG-S	RADIANS Class 2 Green Safety Vest w/ Zipper, Small	\$4.68

SAFETY & PERSONAL PROTECTIVE EQUIPMENT

	Part Number	Description	Price Ea.
	SV2ZG-M	RADIANS Class 2 Green Safety Vest w/ Zipper, Medium	\$4.68
	SV2ZG-L	RADIANS Class 2 Green Safety Vest w/ Zipper, Large	\$4.68
	SV2ZG-XL	RADIANS Class 2 Green Safety Vest w/ Zipper, X-Large	\$4.68
	SV2ZG-2XL	RADIANS Class 2 Green Safety Vest w/ Zipper, 2X-Large	\$4.68
	SV2ZG-3XL	RADIANS Class 2 Green Safety Vest w/ Zipper, 3X-Large	\$4.68
	SV2ZG-4XL	RADIANS Class 2 Green Safety Vest w/ Zipper, 4X-Large	\$4.68
	SV2ZG-5XL	RADIANS Class 2 Green Mesh Safety Vest w/ Zipper, 5X-Large	\$5.15





SAFETY & PERSONAL PROTECTIVE EQUIPMENT

	Part Number	Description	Price Ea.
	SV2ZGS-M	RADIANS Class 2 Green Solid Vest w/Zipper, Medium	\$4.68
	SV2ZGS-L	RADIANS Class 2 Green Solid Vest w/Zipper, Large	\$4.68





SAFETY GLASSES

	BK110	Crews BearKat Safety Glasses, Clear Frame/Lens	\$1.23
---	-------	--	---------------

HARD HATS

	E2RWBLK	Fibre Metal E2RW Hard Hat - Ratchet Suspension, Black	\$14.50
	E2RWBLU	Fibre Metal E2RW Hard Hat - Ratchet Suspension, Blue	\$14.50
	E2RWGRN	Fibre Metal E2RW Hard Hat - Ratchet Suspension, Green	\$14.50
	E2RWGRY	Fibre Metal E2RW Hard Hat - Ratchet Suspension, Gray	\$14.50



SAFETY & PERSONAL PROTECTIVE EQUIPMENT

	Part Number	Description	Price Ea.
	E2RWORG	Fibre Metal E2RW Hard Hat - Ratchet Suspension, Orange	\$14.25
	E2RWRED	Fibre Metal E2RW Hard Hat - Ratchet Suspension, Red	\$14.25
	E2RWWHT	Fibre Metal E2RW Hard Hat - Ratchet Suspension, White	\$14.25
	E2RWSOA	Fibre Metal E2RW Hard Hat – American Eagle	\$32.50

UTILITY KNIFE

	704526	18mm Plastic Snap Off Utility Knife	\$1.50
---	--------	-------------------------------------	---------------

PROTECTIVE SUITS

	M2208S	MELBRAN Yellow Jacket I/O Cuff, Small	\$19.63
	M2208M	MELBRAN Yellow Jacket I/O Cuff, Medium	\$19.63
	M2208L	MELBRAN Yellow Jacket I/O Cuff, Large	\$19.63

SAFETY & PERSONAL PROTECTIVE EQUIPMENT

	Part Number	Description	Price Ea.
	M2208XL	MELBRAN Yellow Jacket I/O Cuff, X-Large	\$19.63
	M22082X	MELBRAN Yellow Jacket I/O Cuff, 2X-Large	\$19.63
	M22083X	MELBRAN Yellow Jacket I/O Cuff, 3X-Large	\$21.65
	M2211XS-KP	MELBRAN Yellow Overall w/Patch and Knee Pad Pockets, X-Small	\$19.63
	M2211S-KP	MELBRAN Yellow Overall w/Patch and Knee Pad Pockets, Small	\$19.63
	M2211M-KP	MELBRAN Yellow Overall w/Patch and Knee Pad Pockets, Medium	\$19.63
	M2211L-KP	MELBRAN Yellow Overall w/Patch and Knee Pad Pockets, Large	\$19.63
	M2211XL-KP	MELBRAN Yellow Overall w/Patch and Knee Pad Pockets, X-Large	\$19.63
	M22112X-KP	MELBRAN Yellow Overall w/Patch and Knee Pad Pockets, 2X-Large	\$19.63
	M22113X-KP	MELBRAN Yellow Overall w/Patch and Knee Pad Pockets, 3X-Large	\$19.63

FIRST AID



NORTH

ADHESIVE BANDAGES

	Part Number	Description	Price
	6710BF	Butterfly Bandage, 10/bag	\$2.05
	016407	Mini Woven, 7/8x1-1/2, 50/box, 12 boxes/case	\$2.50
	010813	Fingertip Bandage Woven, 40/box, 24 boxes/case	\$3.90
	010812	Fingertip Bandage, Large, 25/box, 24 boxes/case	\$3.90
	010811	Knuckle Bandage, 40/box, 24 boxes/case	\$4.75
	010150	Plastic Bandage Strip, 1x3, 50/box 24 boxes/case	\$2.00
	012315	Elastaband, 1x3, 50/box, 24 boxes/case	\$2.90
	010810	Bandage Woven, 7/8x3, 50/box 24 boxes/case	\$3.90
	0198998	Finger Wrap, 3/4"x4-3/4", 24/case	\$1.70
	010819	Woven Patch, 2x3, 25/box, 24 boxes/case	\$3.95
	011325B	Fingertip "8" Woven Blue, 25/box, 72 boxes/case	\$6.60
	013940B	Woven Knuckle Blue, 40/box, 24 boxes/case	\$6.30
	015059B	1x3 Blue Plastic, 100/box, 12 boxes/case	\$5.75
	016459B	1x3 Blue Woven, 100/box, 12 boxes/case	\$7.25

WOUND CARE PRODUCTS

	150910	Antiseptic Wipes, 20/box, 24 boxes/case	\$1.20
	12803V	Cotton Tip App. 25/Vial, 50 Vials/case	\$1.30
	12803VI	Med Swabs (q-tips), 50/Vial, 100 vials/case	\$1.80
	151011	Band Aid Spray, 20oz, 12/case	\$3.90
	151020	First Aid Cream, 10/box, 24 boxes/case	\$2.75
	032205	Hydrogen Peroxide Spray Pump, 2oz, 12/case	\$4.00
	154818	Alcohol Wipes, 50/box, 24 boxes/case	\$1.60
	032203	First Aid Pump Spray, 2 oz, 12/case (case only)	\$5.35
	151019	First Aid Aerosol Spray, 12/case (case only)	\$3.65
	233020	Hydrocortisone 1%, 20/box, 24 boxes/case	\$3.05
	232124	Triplebiotic 1/32oz, 20/box, 24 boxes/case	\$2.85
	1503180	Wound Wipes, 25/box, 24 boxes/case	\$3.70
	28UOC351S	Urgent QR for Cuts and Punctures, 2/Pkg	\$7.75
	269214	Hand and Skin Lotion, 20/box, 24 boxes/case	\$3.30
	281026	Cold Spray, 4oz, 12/case	\$2.40

FIRST AID

ELASTIC WRAPS, GAUZE ROLLS AND TAPES

	Part Number	Description	Price
	028105	Elastic Tape, 1"x5yds, Sold by each or 24/case	\$2.40
	023143	1/2"x5yd tape, Sold by each or 12/case	\$1.40
	032170	Trip-Cut Tape, Sold by each or 12/case	\$3.75
	051820	2" Gauze Roll, Sold by each or 50/case	\$0.30
	051830	3" Gauze Roll, Sold by each or 50/case	\$0.60
	067422	Gauze Pad, 2x2, 10/box, 72 boxes/case	\$1.35
	067433	Gauze Pad, 3x3, 10/box, 36 boxes/case	\$1.40
	067444	Gauze Pad, 4x4, 10/box, 24 boxes/case	\$1.95
	103200T	Co Flex, 2"x5yd, Sold by each or 36/case	\$2.00
	103300T	Co Flex Adhesive, 3"x5yd, Sold by each or 24/case	\$2.65
	103400T	Co Flex Adhesive, 4"x5yd, Sold by each or 18/case	\$2.90

TRAUMA DRESSING

	061910	Bloodstopper Bandage, 60/case	\$2.50
--	--------	-------------------------------	---------------

LATEX GLOVES

	MF-300S	Latex Exam Gloves, Small, 100/box	\$13.90
	MF-300M	Latex Exam Gloves, Medium, 100/box	\$13.90
	MF-300L	Latex Exam Gloves, Large, 100/box	\$13.90
	MF-30XL	Latex Exam Gloves, XLarge, 100/box	\$13.90

MISCELLANEOUS

	045027	First Aid Booklet	\$0.80
	7751H	Finger Cots, Medium, 144/box, 24 boxes/case	\$4.35
	7752	Finger Cots, Large, 144/box, 24 boxes/case	\$4.50
	320001	Splinter out, 10/box, 50 boxes/case	\$2.10
	32190EP	Tweezers with Magnifier, Sold by each or 24/case	\$4.60
	3249320	Tweezer Kit, 3 Slant End, Sold by each or 50/case	\$0.80
	325701P	Bandage Scissors, 5-1/2", Sold by each or 12/case	\$3.00
	3253874	Paramedic Utility Shears, Sold by each or 400/case	\$2.75

FIRST AID

TABLETS

	Part Number	Description	Price
	161512	Aspirin, 2/env., 250/box, 12 boxes/case 325mg	\$6.15
	163250	Pain Stipper, Extra Strength, 250/box, 12 boxes/case	\$9.25
	161617	Aypanal, Extra Strength, 250/box, 12 boxes/case	\$8.85
	166183	Cedaprin, 250/box, 12 boxes/case	\$11.35
	80248	Medique Antacid, 250/box, 12 boxes/case	\$8.20
	210100	Cough Drops, Cherry, 100/box, 12 boxes/case	\$5.45
	2106250	Sinus Decongestant, 250/box, 12 boxes/case	\$8.70
	2107250	Sinus Pain Tablets, 250/box, 12 boxes/case	\$11.95
	2108250	Multi-Symptom Cold Tablets, 250/box, 12 boxes/case	\$17.00
	2799250F	Electrolyte Tablets, 250/box, 12 boxes/case	\$7.35

BURN CARE PRODUCTS

	SD6	Burn Free Dispenser, 6/box	\$1.95
	SD25	Burn Free Dispenser, 25/box	\$8.15
	200206	Water Jel, 2x6, Sold by each, 15/box or 60 boxes/case	\$3.80
	032204	Burn Pump Spray, 2oz, Sold by each or 12/case	\$5.10
	201005	Burn Spray Aerosol, 3oz, Sold by each or 12/case	\$3.35

HOT/COLD PACKS

	30211HB	Kwik Heat Hot Pak, Sold by box of 4, 3boxes/case	\$4.15
	30100K	Cold Pack 6x9 Packet, 1/box, 20 boxes/case	\$1.20
	020667	Cold Pack Unit Refill, 1/box, 50 boxes/case	\$0.90

FIRST AID

EYE WASH/SKIN FLUSHING PRODUCTS

	Part Number	Description	Price
	451F	1oz Swifteez Eye Wash, Single Use, 144/case	\$2.10
	452F	4oz Swifteez Eye Wash, Single Use, 48/case	\$3.20
	454F	Iso Tone Neutralizer, 16 oz, Sold by each, 12/case	\$7.00
	455F	Iso Tone Neutralizer (Tall), 32oz, Sold by each, 12/case	\$9.70
	24906S	Eye Cups, Sold by vial, 6/vial, 24 vials/case	\$2.10
	326734G	Eye Magnet w/Loop, Sold by each, 24/case	\$7.80
	5135	SAS 15 min Flow Gravity Fed Eye Wash, each	\$155.60

LENS CLEANING

	8574GM	Sight Savers, 100/box, 12 boxes/case	\$11.15
--	--------	--------------------------------------	----------------

CPR PRODUCTS AND OXYGEN

	121055	CPR Mask, Gloves, Wipes (Bulk Fill), 50/case	\$9.40
	4270190	CPR Mask, Keychain, 50/case	\$10.55
	LMCB-MBB	CPR Mask, Belt Pouch	\$12.75

FIRST AID

UNITIZED FIRST AID

	Part Number	Description	Price
	020855	Fingertip Bands, 8/box, 100 boxes/case	\$1.20
	020020	Knuckle, 8/box, 100 boxes/case	\$1.15
	020795	Adhesive Bandage, 1x3, Sheer, 16/box, 100 boxes/case	\$0.95
	028001	Elastic Bandage, 1x3, 16/box, 100 boxes/case	\$1.15
	021000	Combo Pak, 25/box, 100 boxes/case	\$3.85
	021201	Iodine Wipe Unitized, 10/box, 100 boxes/case	\$1.20
	020430	3x3 Compress, Gauze Pad	\$1.20
	35144TC	4" Compress	\$1.30
	020370	Triangle Bandage, 40" Cloth, 1/box, 100 boxes/case	\$1.90
	021640	Medical Glove, 2/bag, 250 bags/case	\$2.00
	35134SS	Nox a Sting Swabs, 10/box, 100 boxes/case	\$3.05
	020225	Ammonia Inhalants Unit, 10/box, 100 boxes/case	\$3.55
	020550	Scissors & Forceps, 100/case	\$1.55
	020618	Rescue Space Blanket, 1/box, 50 boxes/case	\$3.45
	020380	Wire Splint, Arm/Leg, 1/box, 100 boxes/case	\$2.80
	020956	Eye Dressing Pads	\$3.35

FIRST AID

FIRST AID KITS



68-100X	FA Kit, 10 Unit w/OXARC Logo (7-1/2x4-1/2x2-3/8)	\$30.75
68-160X	FA Kit, 16 Unit w/OXARC Logo (6-5/16x9-1/16x2-3/8)	\$40.50
68-240X	FA Kit, 24 Unit w/OXARC Logo (9-1/16x9-1/16x2-3/8)	\$52.75
68-360X	FA Kit, 36 Unit w/OXARC Logo (13x11/16x9-1/8x2-3/8)	\$70.75
68116WAOX	FA Kit, Office w/OXARC Logo (7-3/4x9-3/4x3-1/4)	\$69.00
68140LWAOX	Industrial FA Kit, Small OXARC (15-1/2x10-1/2x4-3/4)	\$122.50
68180LWAOX	Industrial FA Kit, Medium OXARC (15x17x15-1/2)	\$165.25
68400LWAOX	Industrial FA Kit, Large OXARC (15x22x5-1/2)	\$197.05
68600LWAOX	Industrial FA Kit, xtra Large OXARC (19-1/2x28-1/4x6-5/8)	\$319.70
340001F	Truck Kit, Bulk, 10 Unit Box, Plastic	\$21.15
242020	Emergency Eye Wash Kit (15-1/2x10-1/2x4-3/4)	\$66.50
202020	Burn Kit	\$119.75
34-6200	Major Emergency Kit	\$110.40
55BF129	Body Fluid Disposal Kit	\$16.25
35230B	Snake/Insect Bite Kit (4x2-1/2x1-1/2)	\$15.75



PARTS LIST

for

1 - 5 lb. Dry Chemical (Fixed Nozzle)

Aluminum Valve Models

- | | |
|-------------------------|----------------------|
| A620 - 1lb. REG | A/B410 - 2 1/2lb. PK |
| 417 - 2 1/2lb. ABC | 425 - 5lb. ABC |
| A/B417 - 2 1/2lb. ABC | 409 - 5lb. REG |
| 403 - 2 1/2lb. REG | A/B409 - 5lb. REG |
| A/B/C403 - 2 1/2lb. REG | 416 - 5lb. PK |
| 410 - 2 1/2lb. PK | A/B416 5lb. PK |

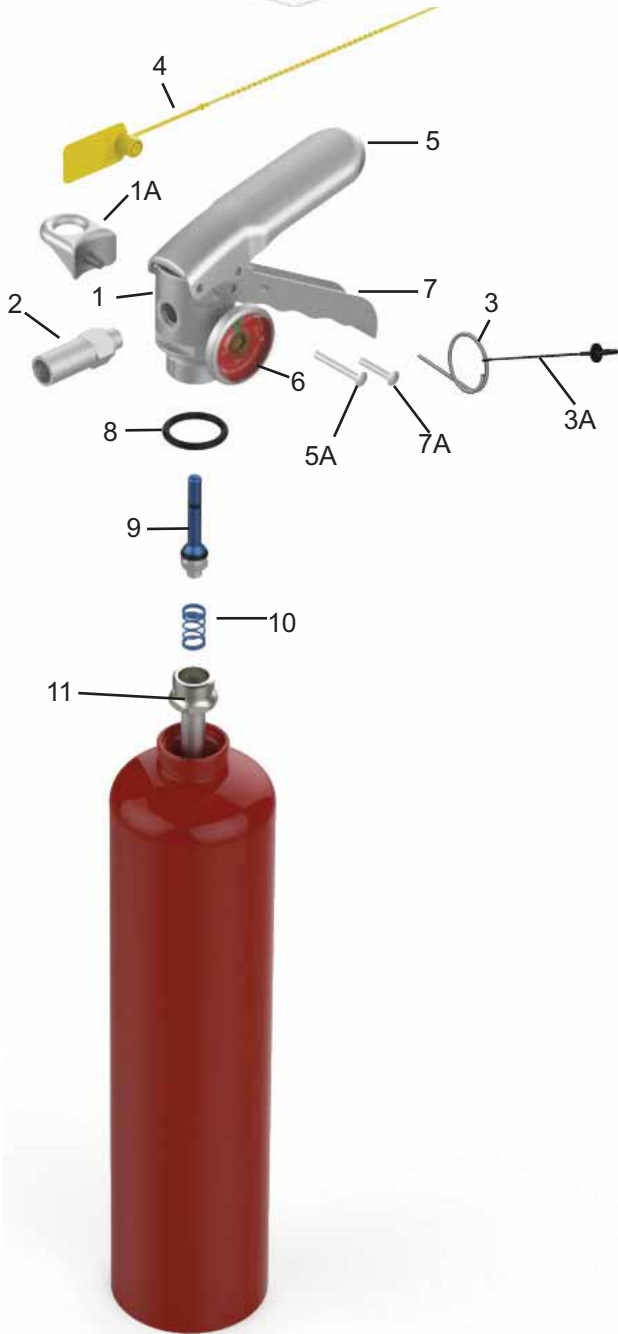

ITEM NO.	PART NO.	DESCRIPTION
1	12699	Modified Valve Assembly
	11823	Standard Valve Assembly
1A	14220	Hanger Loop w/Screw
2	12494	Nozzle - A620 (.076 SHORT)
	01926	417, A/B417 (.129)
	03741	409, A/B409, 416, A/B416 (.173P)
	03211	403, A/B/C 403 (.120ST)
	01276	410, A/B410 (.120)
	01925	425 (.157)
3	00160	Ring Pin
	16268	Ring Pin 1 lb. & 2 1/2 lb.
3A	00532	Chain (Nylon) for Ring Pin
4	01387	Lock Wire Seal (Yellow)
5	11825	Lever & Rivet
5A	01060	Rivet Only for Lever All Valves
5B	02625	Lever & Rivet - MODIFIED VALVE
6	08184	Gauge - 100 PSI for A620
	03103	Gauge - 195 PSI
7	11826	Handle & Rivet
7A	01064	Rivet Only for Handle - ALL VALVES
7B	09001	Handle & Rivet - MODIFIED VALVE
8	05241	Collar O-Ring
9	06092	Valve Stem Assembly
10	01074	Spring
11	06069	Downtube/Retainer Assembly - A620
	01075	417, A417, C403, 403, A403, 410, A410
	06212	409, A/B409, 425, 416, A/B416, B403, B410, B417
ALL BRACKETS - SEE BRACKET PAGE		
ALL FILL & HYDROTEST ADAPTERS - SEE ADAPTERS PAGE		
All Valve Assemblies include Valve Body, Gauge, Lever and Handle (Loop and Screw on 11823)		



PARTS LIST

for

5 - 20 lb. Dry Chemical (Hose & Horn)

Aluminum Valve Models

- | | |
|---------------------|--------------------|
| 400 - 5lb. ABC | 443 - 6lb. ABC |
| A400 - 5lb. ABC | A/B443 - 6lb. ABC |
| A/B402 - 5lb. ABC | 456 - 10lb. ABC |
| 500 - 5lb. ABC | A/B456 - 10lb. ABC |
| A/B500 - 5lb. ABC | A/B457 - 10lb. REG |
| 453 - 5.5lb. REG | A411 - 20lb. ABC |
| A/B453 - 5.5lb. REG | A412 - 20lb. REG |
| 479 - 5lb. PK | A413 - 20lb. PK |
| A/B479 - 5lb. PK | |



ITEM NO.	PART NO.	DESCRIPTION
1	11823	Valve Assembly - 5, 5½, 6 & 10 lb.
	11824	Valve Assembly - 20 lb.
1A	14220	Hanger Loop with Screw
2	07641	Hose & Horn Ass'y - 400, A400 (.149)
	14849	A/B402 (.157)
	06215	453, A/B453, A/B500 (.147)
	05248	479, 500, 443, A/B479, A/B443 (.152)
	05564	456, A/B456, A/B457 (.191)
	11221	A411 (.209)
	11223	A412, A413 (.177)
3	01532	Hose Gasket (O-Ring) - ALL 5, 6, & 10 lb.
	06978	A411, A412, A413
4	00160	Ring Pin
4A	00532	Chain (Nylon) for Ring Pin
5	01387	Lock Wire Seal (Yellow)
6	11825	Lever & Rivet
6A	01060	Rivet Only for Lever
6B	02625	Lever & Rivet - MODIFIED VALVE
7	03103	Gauge - 195 PSI
8	11826	Handle & Rivet - 5 to 10 lb.
	12405	20 lb.
8A	01064	Rivet Only for Handle - ALL 5 - 10 lb.
	12201	Rivet Only for Handle - 20 LB.
8B	09001	Lever & Rivet - MODIFIED VALVE
9	05241	Collar O-Ring
10	06092	Valve Stem Assembly
11	01074	Spring
12	06212	Downtube/Retainer Ass'y - A/B402, 453, 479, 500, A/B453, A/B479, A/B500
	03397	400, 443, A400, A/B443
	01519	456, A/B456, A/B457
	11674	A411, A412, A413
13	15747	Strap & Clip Ass'y (Black Plastic - 3/8" Hose) ALL 5 - 10 lb.
	14778	Strap & Clip Ass'y (Black Plastic - 1/2" Hose) ALL 20 lb.
14	12383	Protective Ring for Bottom of 20 LB. Cylinder - 7" Diameter

ALL BRACKETS - SEE BRACKET PAGE

ALL FILL & HYDROTEST ADAPTERS - SEE ADAPTERS PAGE

All Valve Assemblies include Valve Body, Gauge, Lever and Handle, Loop and Screw

P/N: 5248 & 6215 Hose & Horn Ass'y are both valid for use on Models 500 & 500T



PARTS LIST

for

5 - 30 lb. Dry Chemical Brass Valve Models

- | | | |
|-----------------|------------------|-----------------|
| 424 - 5lb. ABC | 419 - 10lb. ABC | B460 - 10lb. PK |
| B424 - 5lb. ABC | 441 - 10lb. ABC | 423 - 20lb. ABC |
| 461 - 6lb. ABC | B441 - 10lb. ABC | 408 - 20lb. REG |
| B461 - 6lb. ABC | 447 - 10lb. REG | 415 - 20lb. PK |
| 462 - 6lb. REG | B447 - 10lb. REG | 692 - 30lb. ABC |
| B462 - 6lb. REG | 460 - 10lb. PK | 693 - 30lb. PK |

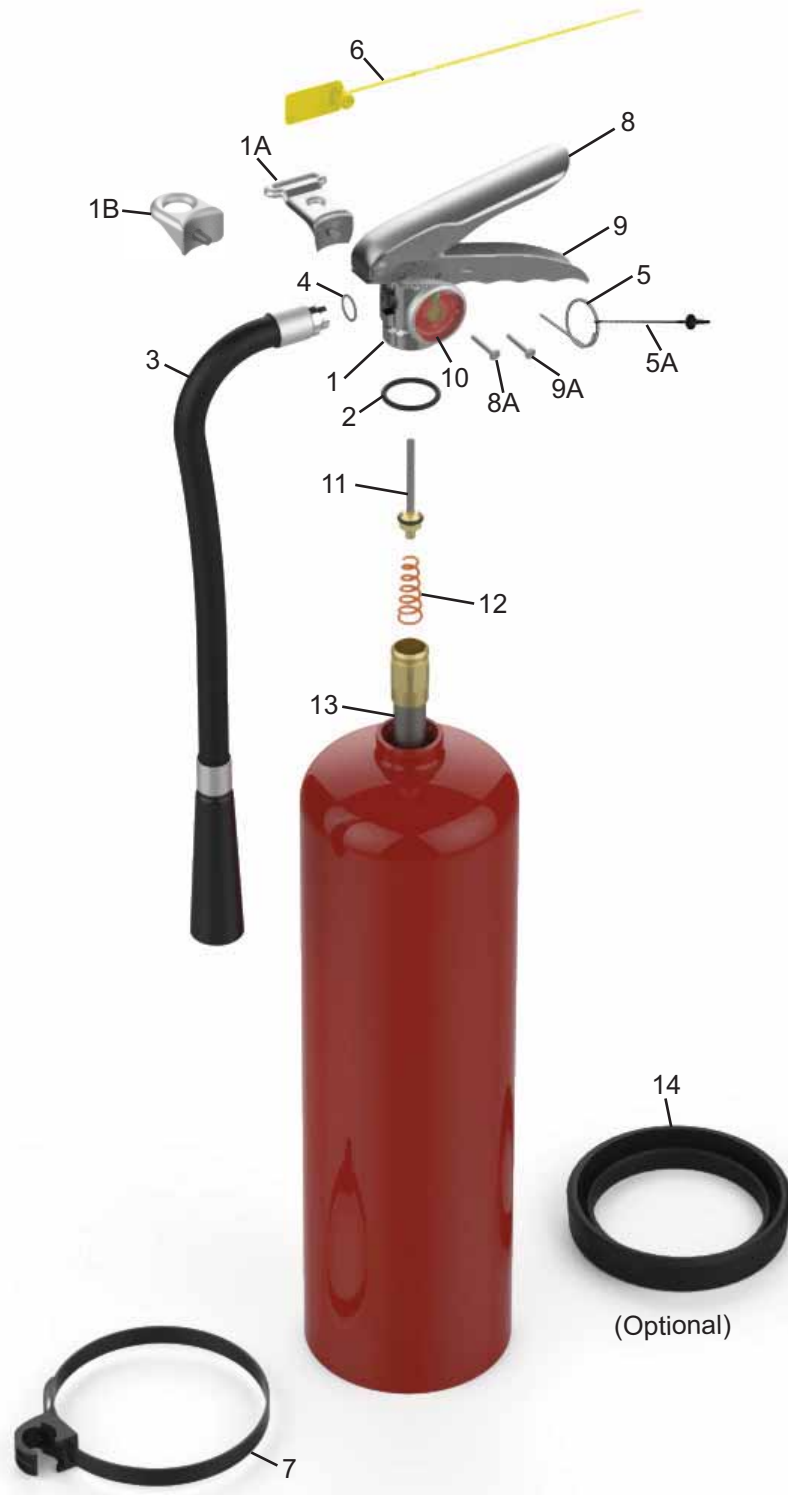

ITEM NO.	PART NO.	DESCRIPTION
1	11952	Valve Assembly - ALL MODELS
1A	15363	Hanger Loop with Screw - "B" Models B441, B447, B460 (10 lb.)
1B	16694	Hanger Loop with Screw 5 lb., 6 lb., & 20 lb.
	17144	Hanger Loop with Screw 692, 693
2	05240	Collar O-Ring
3	03753	Hose & Horn Ass'y - 424, B424 (.140)
	01178	441, 447-B447 (.173)
	03753	461-B461, 462-B462 (.140)
	06095	419, 460-B460, B441, (.152)
	03339	423 (.174)
	05174	415 (.177)
	03332	408 (.173)
	12603	692 (.216)
	13439	693 (.191)
	4	06978
5	00160	Ring Pin, Stainless Steel
5A	00532	Chain (Nylon) for Ring Pin
6	01387	Lock Wire Seal (Yellow)
	15747	Strap & Hose Clip Ass'y (Black Plastic) 3/8" ALL 4 1/4 & 5" Diameter Cylinders (5/6/10 lb.)
	14778	Strap & Clip Assembly (Black Plastic) 1/2" ALL 7" Diameter Cylinders (20 lb.)
	14871	Strap & Hose Clip Ass'y (Black Plastic) 1/2" ALL 8" Diameter Cylinders (30 lb.)
8	07762	Lever & Rivet - ALL MODELS
8A	01563	Rivet Only for Lever
9	09020	Handle & Rivets - ALL MODELS
9A	01564	Rivets Only for Handle (2 Required)
10	03965	Gauge - 195 PSI
11	06093	Valve Stem Assembly
12	00383	Spring
13	01696	Downtube/Retainer Ass'y - 424-B424 (5lb.)
	01700	419 (10 lb. Short)
	03754	461-B461, 462-B462 (6 lb.)
	02609	441-B441, 447-B447, 460-B460 (10 lb. Tall)
	01667	408, 415, 423 (20 lb.)
	09583	692, 693 (30 lb.)
14	12383	Protective Ring for Bottom of Cylinder - 7" (20 lb.)
	12952	Protective Ring for Bottom of Cylinder - 8" (30 lb.)
ALL BRACKETS - SEE BRACKET PAGE		
ALL FILL & HYDROTEST ADAPTERS - SEE ADAPTERS PAGE		
All Valve Assemblies include Valve Body, Gauge, Lever and Handle		



PARTS LIST for 10 - 20 lb. High Flow Dry Chemical Brass Valve Models

- 720 - 10lb. ABC
- 721 - 10lb. REG
- 722 - 10lb. PK
- 760 - 20lb. ABC
- 761 - 20lb. REG
- 762 - 20lb. PK

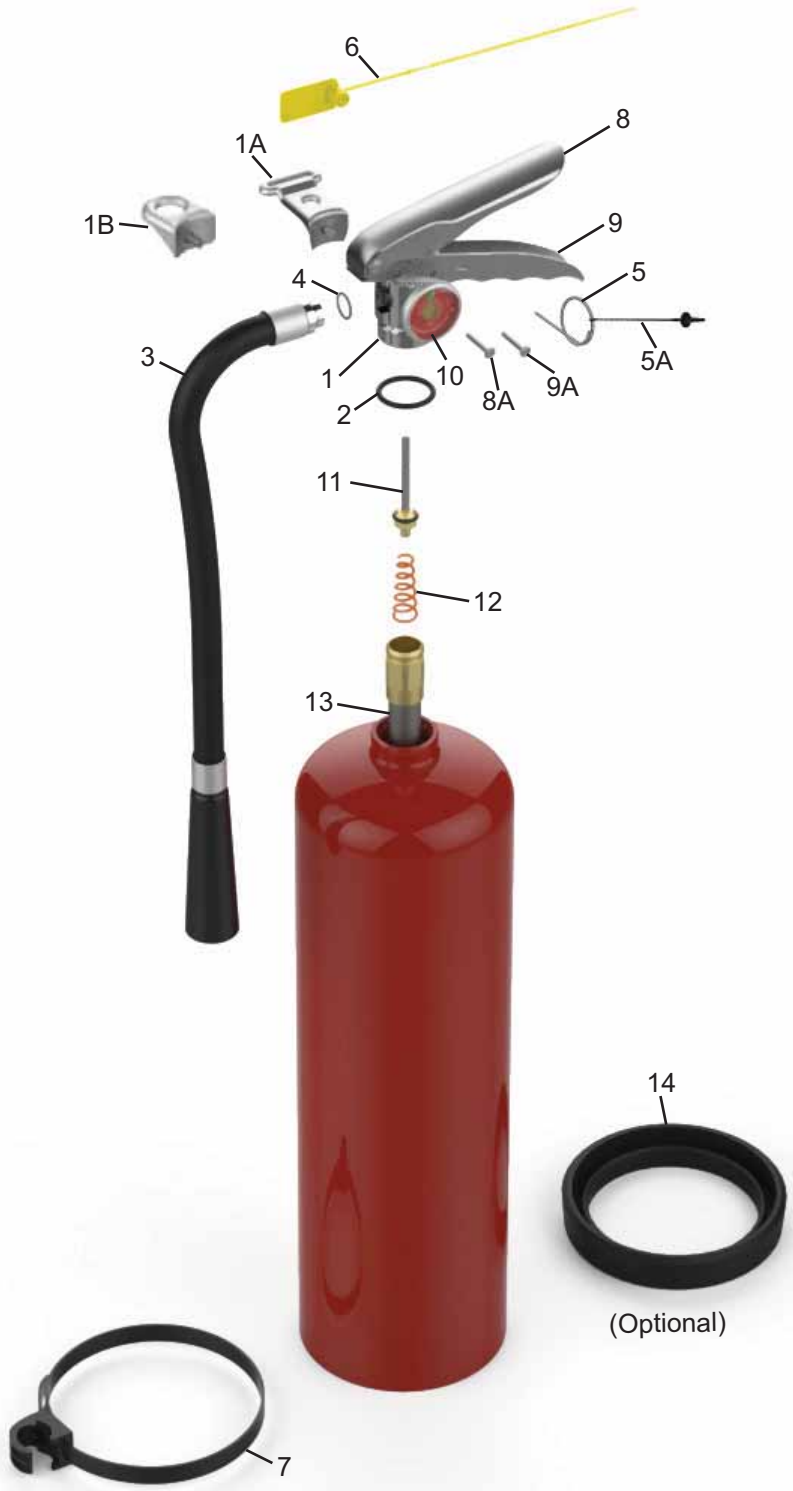

ITEM NO.	PART NO.	DESCRIPTION
1	11952	Valve Assembly - ALL MODELS
1A	15363	Hanger Loop with Screw 720, 721, 722 (10 lb.)
1B	16694	Hanger Loop with Screw 760,761,762 (20 lb.)
2	05240	Collar O-Ring
3	20914	Hose & Horn Ass'y - 720 (.312)
	20908	721 , 722 (.250)
	20912	760 (.266)
	14044	761 (.234)
	20910	762 (.228)
4	06978	Hose Gasket (O-Ring)
5	00160	Ring Pin, Stainless Steel
5A	00532	Chain (Nylon) for Ring Pin
6	01387	Lock Wire Seal (Yellow)
7	14778	Strap & Clip Assembly (Black Plastic) 1/2" ALL 7" Diameter Cylinders (20 lb.)
8	07762	Lever & Rivet - ALL MODELS
8A	01563	Rivet Only for Lever
9	09020	Handle & Rivets - ALL MODELS
9A	01564	Rivets Only for Handle (2 Required)
10	03965	Gauge - 195 PSI
11	06093	Valve Stem Assembly
12	00383	Spring
13	01667	Downtube/Retainer Ass'y - 760, 761, 762 (20 lb.)
	02609	720, 721, 722 (10 lb.)
14	12383	Protective Ring for Bottom of Cylinder - 7" (20 lb.)

ALL BRACKETS - SEE BRACKET PAGE

ALL FILL & HYDROTEST ADAPTERS - SEE ADAPTERS PAGE

All Valve Assemblies include Valve Body, Gauge, Lever and Handle



PARTS LIST

for

1³/₄ - 2¹/₂ Gal. Water Mist Extinguisher Models

270 / B270 / 270NM / 270CG - 1 3/4 gal.
 272 / B272 / 272NM / 272CG - 2 1/2 gal.



ITEM NO.	PART NO.	DESCRIPTION
1	17615	Valve Assembly - ALL MODELS
2	14380	Hanger Loop with Screw (Optional)
3	14184	Hose & Wand Assembly - 272, B272, 272NM, B272CG
	14318	Hose & Wand Assembly - 270, B270, 270NM, B270CG
4	06901	Ring Pin, Stainless Steel (Non-Magnetic)
4A	00532	Chain (Nylon) for Ring Pin
5	01387	Lock Wire Seal (Yellow)
6	07762	Lever & Rivet - ALL MODELS
6A	01563	Rivet Only for Lever
7	09020	Handle & Rivets - ALL MODELS
7A	01564	Rivets Only for Handle (2 Required)
8	06479	Gauge - 100 PSI (S/S Tube)
9	05240	Collar O-Ring
10	06093	Valve Stem Assembly
11	00383	Spring
12	15943	Downtube/Retainer Ass'y - 272, B272, 272NM, B272CG
	15941	Downtube/Retainer Ass'y - 270, B270, 270NM, B270CG
13	05690	O-Ring Downtube / Retainer
14	02595	Fill Tube 272, B272 (Black)
	14316	Fill Tube 270, B270 (Red)
15	14187	Foot Stand (Blue)
16	14838	Strap & Clip Ass'y [Blue Plastic - 3/8"] (2 Required)
17	21777	Rubber Footstand 7"
	21854	Rubber Footstand Adhesive (Not Shown)
ALL BRACKETS - SEE BRACKET PAGE		
ALL FILL & HYDROTEST ADAPTERS - SEE ADAPTERS PAGE		
All Valve Assemblies include Valve Body, Gauge, Collar Nut, O-Ring, Lever and Handle		





PARTS LIST for 6 Liter and 2½ Gal. Wet Chemical Models

260/B260 / B260CG - 6 Liter
262/B262 / B262CG - 2 1/2 gal.

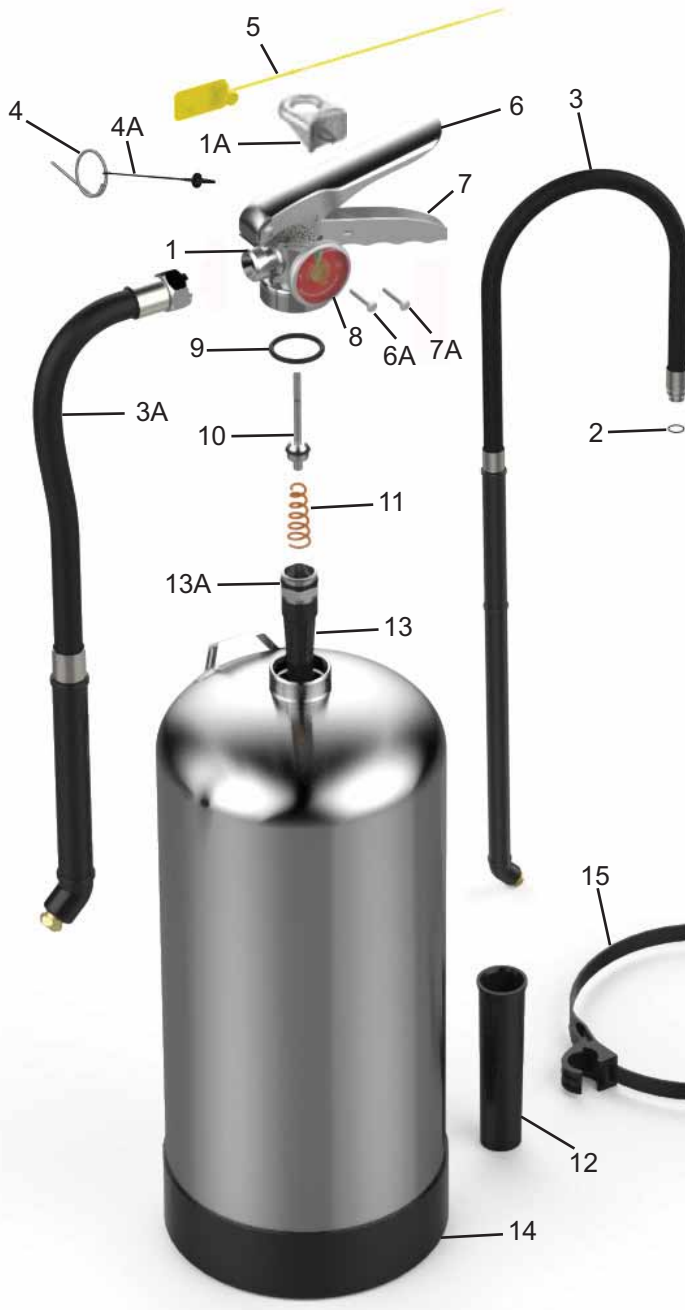

ITEM NO.	PART NO.	DESCRIPTION
1	14345	Valve Assembly - 260, 262
	14249	Valve Assembly - B260, B260CG, B262, B262CG
1A	14380	Hanger Loop with Screw (OPTIONAL)
2	06978	Hose Gasket (O-Ring) 260, 262
3	14588	Hose & Wand Assembly - 260, 262
3A	16043	Hose & Nozzle Assembly - B260, B260CG
	16101	Hose & Nozzle Assembly - B262, B262CG
4	00160	Ring Pin, Stainless Steel
4A	00532	Chain (Nylon) for Ring Pin
5	01387	Lock Wire Seal (Yellow)
6	07762	Lever & Rivet - ALL MODELS
6A	01563	Rivet Only for Lever
7	09020	Handle & Rivets - ALL MODELS
7A	01564	Rivets Only for Handle (2 Required)
8	17420	Gauge - 100 PSI (S/S Tube) and Thread
9	05240	Collar O-Ring
10	14878	Valve Stem Assembly
11	00383	Spring
12	02595	Fill Tube
13	16266	Downtube/Retainer Ass'y - 260, B260, B260CG
	16267	Downtube/Retainer Ass'y - 262, B262, B262CG
13A	05690	O-Ring Downtube / Retainer
14	03109	Foot Stand (Black)
15	14776	Strap & Clip Ass'y [Black Plastic - 3/8"]
16	14669	Placard (English/Spanish)
	15874	Placard (English/French)
17	21777	Rubber Footstand 7"
	21854	Rubber Footstand Adhesive (Not Shown)
		ALL BRACKETS - SEE BRACKET PAGE
		ALL FILL & HYDROTEST ADAPTERS - SEE ADAPTERS PAGE
		All Valve Assemblies include Valve Body, Gauge, Collar Nut, O-Ring, Lever and Handle





PARTS LIST

for

6 Liter and 2½ Gal. Water & Foam Models

- 240 - 2 1/2 Gallon Water
- 250 - 2 1/2 Gallon AR-AFFF Foam
- 252 - 2 1/2 Gallon FFFP Foam
- 254 - 6 Liter AR-AFFF Foam



ITEM NO.	PART NO.	DESCRIPTION
1	13281	Valve Assembly - 240 w/ air valve
	17616	Valve Assembly - 250, 252, 254 w/o air valve
1A	14380	Hanger Loop with Screw (OPTIONAL ON FOAM)
2	06978	Hose Gasket (O-Ring)
3	06999	Hose & Nozzle Assembly - 240
3A	07000	Hose & Aspirated Black Nozzle Assembly - 250
	06982	Hose & Aspirated Gray Nozzle Assembly - 252
3B	13162	Hose & Spray Nozzle Assembly - 254
4	00155	Pressure Valve & Cap Assembly - 240 Only
4A	00158	Cap Only for Pressure Valve - 240 Only
5	00160	Ring, Pin Stainless Steel
5A	00532	Chain (Nylon) for Ring Pin
6	01387	Lock Wire Seal (Yellow)
7	07762	Lever & Rivet - ALL MODELS
7A	01563	Rivet Only for Lever
8	09020	Handle & Rivets - ALL MODELS
8A	01564	Rivets Only for Handle (2 Required)
9	06479	Gauge - 100 PSI (S/S Tube)
10	05240	Collar O-Ring
11	06093	Valve Stem Assembly
12	00383	Spring
13	02595	Fill Tube
14	05690	O-Ring Downtube / Retainer
	15943	Downtube/Retainer Ass'y - 240,250,252
15	15941	Downtube/Retainer Ass'y - 254
	03576	Foot Stand with Clip (Black) - 240
	03776	Foot Stand with Post (Black) - 250, 252
16	03109	Foot Stand (Black) - 254
	14776	Strap & Clip Assembly (Model 254 Only)
17	21777	Rubber Footstand 7"
*	21854	Rubber Footstand Adhesive
ALL BRACKETS - SEE BRACKET PAGE		
ALL FILL & HYDROTEST ADAPTERS - SEE ADAPTERS PAGE		
All Valve Assemblies include Valve Body, Gauge, Collar Nut, O-Ring, Lever and Handle		
* Not Shown		



PARTS LIST for 6 Kg - 30 lb. Dry Chemical High Performance Models

564 - 20lb. ABC CF 568 - 30lb. REG FF 589 - 30lb. ABC CF
 566 - 20lb. PK FF 569 - 30lb. PK FF 591 - 30lb. PK CF
 567 - 30lb. ABC FF 580 - 20lb. PK FF 592 - 6kg. ABC CF
 581 - 20lb. ABC FF 594 - 6kg. ABC FF
 582 - 20lb. REG FF 595 - 6kg. PK FF
 584 - 20lb. PK FF 599 - 6kg. PK CF



ITEM NO.	PART NO.	DESCRIPTION
1	14874	Valve Assembly - (Female Outlet Thread)
2	05240	Collar O-Ring
3*	14785	Hose & Horn Assembly - 594 (.213)
	14791	Hose & Horn Assembly - 595 (.204)
	14788	Hose & Horn Assembly - 580, 581, 582 (.250)
	14790	Hose & Horn Assembly - 592 (.166)
	14794	Hose & Horn Assembly - 599 (.149)
	14787	Hose & Horn Assembly - 564 (.166)
	14786	Hose & Horn Assembly - 566 (.157)
	14789	Hose & Horn Assembly - 567, 568, 569, 584 (.312)
	14947	Hose & Horn Assembly - 589 (.213)
	14948	Hose & Horn Assembly - 591 (.180)
3A	14778	Strap & Clip Assembly (Black Plastic) 1/2" Hose 6kg (13.2 lb.) & 20 lb.
	14871	Strap & Clip Assembly (Black Plastic) 1/2" Hose 30 lb.
4	06978	Hose Gasket (O-Ring)
5	00160	Ring, Pin Stainless Steel
6	00532	Chain (Nylon) for Ring Pin
7	01387	Lock Wire Seal (Yellow)
8	09584	Hanger Loop with Screw
9	09840	Lever & Rivet - ALL MODELS
9A	01563	Rivet Only for Lever
10	09020	Handle & Rivets - ALL MODELS
10A	01564	Rivets Only for Handle (2 Required)
11	05225	Gauge - 240 PSI
12	09102	Gauge Guard, Chrome Plated Brass
13	06093	Valve Stem Assembly
14	00383	Spring
15	01700	Downtube/Retainer Ass'y - 6kg (13.2 lb.)
	01667	Downtube/Retainer Ass'y - 20 lb.
	09583	Downtube/Retainer Ass'y - 30 lb.
16	12383	Protective Foot Ring for Bottom of Cylinder 7" DIA - 20lb. & 6kg. (13.2lb.)
	12952	Protective Foot Ring for Bottom of Cylinder 8" DIA - 30lb.
17	23504	Nameplate 592, 594
	23505	Nameplate 595, 599
	23506	Nameplate 564, 581
	23507	Nameplate 566, 580, 584
	23508	Nameplate 582
	23509	Nameplate 567, 589
	23510	Nameplate 569, 591
	23511	Nameplate 568
		All Valve Assemblies include Valve Body, Gauge, Gauge Guard, Hanger Loop, Lever and Handle

* Nameplates do not include UL and USCG Listing.

* Hose assemblies for older extinguishers utilizing a swivel type connector are no longer available. Order valve assembly 14874 and hose listed above for that model.



PARTS LIST

for

1 1/4 - 20 lb. Halon 1211 Extinguisher Models

- | | | |
|--------------------|----------------|---------------|
| 344 - 1 1/4 lb. | A/C354 - 3 lb. | 371 - 13 lb. |
| A344 - 1 1/4 lb. | 355 - 5 lb. | B371 - 13 lb. |
| 352 - 2 1/2 lb. | A355 - 5 lb. | 361 - 17 lb. |
| A/C352 - 2 1/2 lb. | B355 - 5 lb. | B361 - 17 lb. |
| 354 - 3 lb. | 369 - 9 lb. | 372 - 20 lb. |
| | B369 - 9 lb. | B372 - 20 lb. |

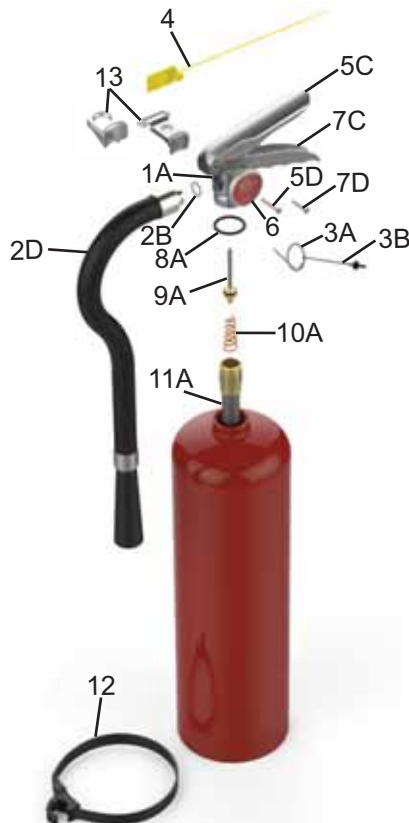
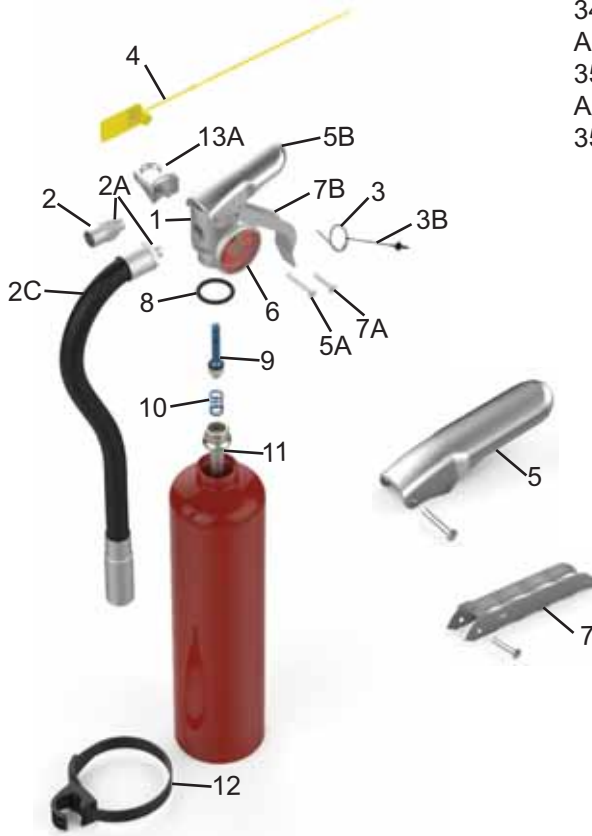

ITEM NO.	PART NO.	DESCRIPTION
1	11953	Valve Assembly - ALUMINUM MODELS (Except 344, A344)
	12597	Valve Assembly - 344, A344
1A	11954	Valve Assembly - ALL BRASS MODELS
2	06066	Nozzle with O-Ring - 344, A344 (.067)
	07115	Nozzle with O-Ring - 352, A/C352 (.098)
	01727	Nozzle with O-Ring - 355, A/B355 (.144)
2A	01532	Hose/Nozzle Gasket (O-Ring) - Aluminum Valve
2B	06978	Hose Gasket (O-Ring) - Brass Valve
2C	06421	Hose & Horn Assembly - 354, A/C354 (.098)
2D	05180	Hose & Horn Assembly - 369, B369 (.216)
	05178	Hose & Horn Assembly - 371, B371 (.234)
	05176	Hose & Horn Assembly - 361 (.152)
	05174	Hose & Horn Assembly - 372 (.177)
3	16268	Ring Pin 1 1/4 lb., 2 1/2 lb.
3A	00160	Ring Pin, Stainless Steel
3B	00532	Chain (Nylon) for Ring Pin
4	01387	Lock Wire Seal (Yellow)
5	11825	Lever & Rivet
5A	01060	Rivet Only for Lever - ALL ALUMINUM MODELS
5B	02625	Lever & Rivet - MOD Valve
5C	07762	Lever & Rivet - Brass Valve Models
5D	01563	Rivet Only for Lever - Brass Valve
6	04839	Gauge - 100 PSI - 344, A344
	03105	Gauge - 125 PSI - 352, A/C352, 355, A/B355
	03106	Gauge - 195 PSI - 354, A/C354, B361, 369, B369, 371, B371, 372
7	11826	Handle & Rivet
7A	01064	Rivet Only for Handle - ALL ALUMINUM MODELS
7B	09001	Handle & Rivet - MOD Valve
7C	09020	Handle & Rivet - Brass Valve
7D	01564	Rivets for Handle (2 Required) - Brass Valve
8	05241	Collar O-Ring - Aluminum Valve
8A	05240	Collar O-Ring - Brass Valve
9	06092	Valve Stem Assembly - Aluminum Valve
9A	06093	Valve Stem Assembly - Brass Valve
10	01074	Spring - All Aluminum Valve
10A	00383	Spring - All Brass Valve
11	06069	Downtube/Retainer Ass'y - 344, A344
	01075	Downtube/Retainer Ass'y - 352, A/C352, 354, A/C354
	06212	Downtube/Retainer Ass'y - 355, A/B355
11A	03754	Downtube/Retainer Ass'y - 369, B369
	02609	Downtube/Retainer Ass'y - 371, B371
	01667	Downtube/Retainer Ass'y - B361, B372
12	15747	Strap & Clip Assembly (Black Plastic) 3/8" Hose 354, A/C354
	14778	Strap & Clip Assembly (Black Plastic) 1/2" Hose 361, 372, 369, B369, 371, B371
13	15363	Hanger Loop with Screw B371
	16694	Hanger Loop with Screw 361, B369, 372
13A	14220	Hanger Loop with Screw - Aluminum Valve
ALL BRACKETS - SEE BRACKET PAGE		
ALL FILL & HYDROTEST ADAPTERS - SEE ADAPTERS PAGE		
All Valve Assemblies include Valve Body, Gauge, Lever and Handle (Loop and Screw 11953)		



PARTS LIST

for

1.4lb. - 15½ lb. Halotron I Extinguisher Models

- | | |
|-----------------|-----------------|
| A384 - 1.4lb. | 387 - 11lb. |
| A385 - 2 1/2lb. | 397 - 11lb. |
| B385 - 2 1/2lb. | 388 - 15 1/2lb. |
| A386 - 5lb. | 398 - 15 1/2lb. |
| B386 - 5lb. | |
| B394 - 5 1/2lb. | |

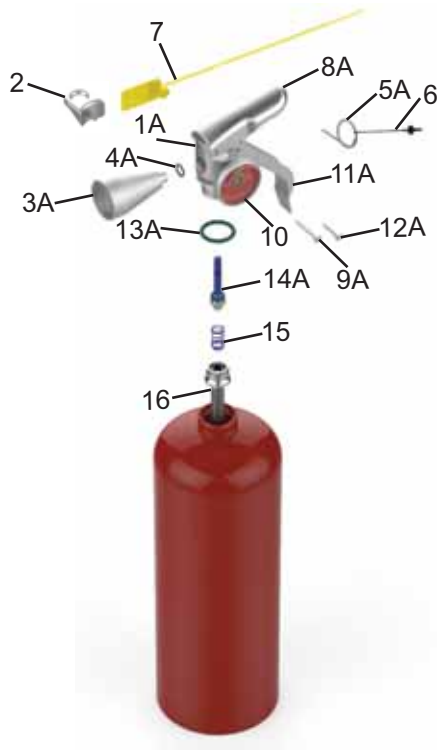

ITEM NO.	PART NO.	DESCRIPTION
1	14527	Valve Assembly - 387, 388, 397, 398
1A	14525	Valve Assembly - 384
	14526	Valve Assembly - 385, B385, 386, B386
	16331	Valve Assembly - B394
2	14220	Hanger Loop with Screw - 384, A/B385, A/B386, B394
	16694	Hanger Loop with Screw - 387, 388, 397, 398
3	14436	Hose & Nozzle Assembly - 387, 397 (.247)
	14449	Hose & Nozzle Assembly - 388, 398, (.295)
3A	14407	Nozzle - 384 (.121)
	14408	Nozzle - A/B385 (.166)
	14409	Nozzle - A/B386, B394 (.277)
4	06978	O-Ring Hose Assembly, Brass Valve
4A	01532	O-Ring, Nozzle - Aluminum Valve
5	00160	Ring Pin
5A	16268	Ring Pin 1 1/4, 2 1/2
6	00532	Chain (Nylon) for Ring Pin - ALL
7	01387	Lock Wire Seal (Yellow) - ALL
8	07762	Lever & Rivet - All Brass Valve
8A	02625	Lever & Rivet - MOD Aluminum Valve
	11825	Lever & Rivet - Aluminum Valve
9	01563	Rivet Only for Lever - Brass Valve
9A	01060	Rivet Only for Lever - Aluminum Valve
10	14418	Gauge - 125 PSI - 384, 387, 388, 397, 398
	14417	Gauge - 100 PSI - A/B385, A/B386
	16332	Gauge - 150 PSI - B394
11	09020	Handle & Rivets - 387, 388, 397, 398
11A	09001	Handle & Rivet - MOD Aluminum Valve
	11826	Handle & Rivet - Aluminum Valve
12	01564	Rivet Only for Handle (2 Required) - Brass Valve
12A	01064	Rivet Only for Handle - Aluminum Valve
13	13305	Collar O-Ring (Green) - Brass Valve
13A	14268	Collar O-Ring (Green) - Aluminum Valve
14	13288	Valve Stem Assembly (Green Seal) - Brass Valve
14A	14327	Valve Stem Assembly (Green Seal) - Aluminum Valve
15	01074	Spring - All Aluminum Valve
15A	00383	Spring - All Brass Valve
16	06069	Downtube/Retainer Ass'y - 384
	01075	Downtube/Retainer Ass'y - 385
	06212	Downtube/Retainer Ass'y - A/B386, B385, B394
	15507	Downtube/Retainer Ass'y - 397, 398
17	14778	Strap & Clip Assembly (Black Plastic) 1/2" Hose 387, 388, 397, 398

All Valve Assemblies include New Valve Body, Gauge, Lever and Handle. (Loop & Screw 14526 also includes hanger loop.) (16331 is complete valve w/ downtube)



PARTS LIST for 2½ / 5 lb. Carbon Dioxide Extinguisher Model

- 320 - 2 1/2 lb.
- 320NM - 2 1/2 lb.
- 321 - 2 1/2 lb.
- 321M - 2 1/2 lb.
- 322 - 5 lb.
- 322NM - 5 lb.

NM - Non Magnetic
M - Military

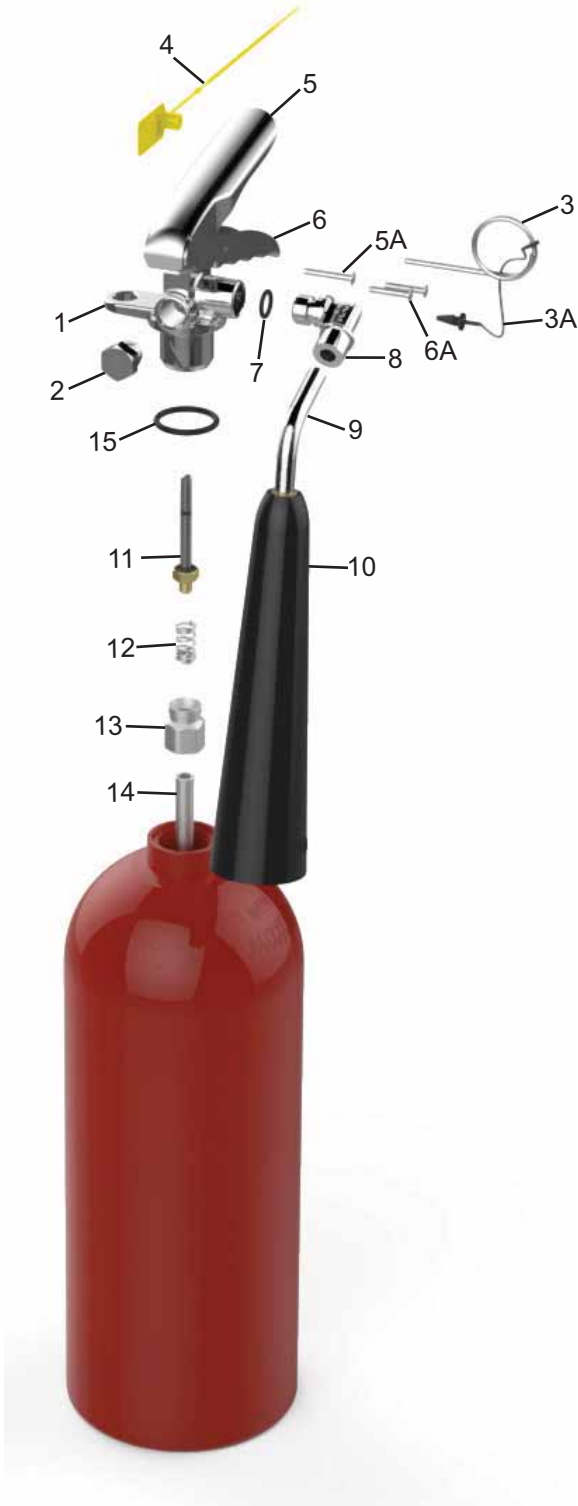

ITEM NO.	PART NO.	DESCRIPTION
1	03090	Valve Assembly - 322, (Does not include elbow or downtube)
	22403	Valve Assembly - 320
	22455	Valve Assembly - 321M
2	04000	Safety Disc, Gasket and Nut Assembly - 320, 322
	22895	Safety Disc, Gasket and Nut Assembly - 321M
3	00160	Ring Pin, Stainless Steel - 322
	06901	Ring Pin, Stainless Steel Non-Magnetic - 320NM, 322NM
	16268	Ring Pin, Stainless Steel (Small) - 320, 321, 321M
3A	00532	Chain (Nylon) for Ring Pin
4	01387	Lock Wire Seal (Yellow) - ALL
	07762	Lever & Rivet - 322
5	23076	Lever & Rivet - 320, 321M
	01563	Rivet Only for Lever
6	09020	Handle & Rivets - 322
	23077	Handle & Rivets - 320, 321M
6A	01564	Rivet Only for Handle (2 Required)
	05689	O-Ring for Elbow
8	02735	Elbow with O-Ring
	01769	Discharge Tube - 322
9	22582	Discharge Tube - 320, 321M
	01772	Horn - 322
10	22400	Horn - 320, 321M
	01539	Valve Stem Assembly
12	00501	Spring
13	00503	Retainer
14	00533	Downtube - 322
	22443	Downtube - 320, 321M
15	01124	Collar O-Ring - 1 1/8"

All Valve Assemblies include Valve Body, Valve Stem Assembly, Spring, Retainer, Safety Disc, Lever and Handle



PARTS LIST

for

10 - 20 lb. Carbon Dioxide Extinguisher Models

330 - 10 lb.

331 - 15 lb.

332 - 20 lb.



ITEM NO.	PART NO.	DESCRIPTION
1	03090	Valve Assembly (Does not include elbow or downtube)
2	04000	Safety Disc, Gasket and Nut Assembly
3	00160	Ring Pin, Stainless Steel
	06901	Ring Pin, Stainless Steel Non Magnetic
3A	00532	Chain (Nylon) for Ring Pin
4	01387	Lock Wire Seal (Yellow) - ALL
5	07762	Lever & Rivet
5A	01563	Rivet Only for Lever
6	09020	Handle & Rivets
6A	01564	Rivet Only for Handle (2 Required)
7	02309	Elbow with O-Ring and Spacer
7A	05689	O-Ring for Elbow
7B	02216	Nylon Spacer for Elbow
8	01776	Hose Assembly - 330, 331, 332
9	01782	Hose & Horn Assembly - 330
	01705	Hose & Horn Assembly - 331, 332
10	00594	U-Pin
11	01777	Nozzle
12	00572	Horn - 330
	00593	Horn - 331, 332
13	01539	Valve Stem Assembly
14	00501	Spring
15	00503	Retainer
16	00564	Downtube - 330
	00589	Downtube - 331, 332
17	01124	Collar O-Ring - 1 1/8"
18	20570	Strap & Clip - 330, 331
	20571	Strap & Clip - 332

All Valve Assemblies include Valve Body, Stem Assembly, Spring, Retainer, Safety Disc, Lever and Handle
*** Not Shown**



PARTS LIST for 30 lb. Class D Extinguisher Models

570 - Sodium Chloride (Super D)
 B570 - Sodium Chloride (Super D)
 571 - Copper
 B571 - Copper



ITEM NO.	PART NO.	DESCRIPTION
1	11952	Valve Assembly
1A	17144	Hanger Loop with Screw B570, B571
2	05240	Collar O-Ring
3	10744	Hose Ass'y w/ 1/2" Male Quick Connect
4	10802	Female 1/2" Female Quick Connect
4A	09073	O-Ring for Quick Connect
5	10800	Extension Applicator
5A	14595	Horn
6	06978	Hose Gasket (O-Ring)
7	00160	Ring Pin, Stainless Steel
8	00532	Chain (Nylon) for Ring Pin
9	01387	Lock Wire Seal (Yellow)
10	07762	Lever & Rivet
11	01563	Rivet Only for Lever
12	09020	Handle & Rivets
13	01564	Rivets Only for Handle (2 Required)
14	03965	Gauge - 195 PSI
15	06093	Valve Stem Assembly
16	00383	Spring - 570, 571
	17139	Spring - B570, B571
17	17215	Downtube/Retainer Ass'y - 570, 571
	17214	Downtube/Retainer Ass'y - B570, B571
18	23068	Strap & Clip - 570, 571
	20572	Strap & Clip - B570, B571
19	12383	Protective Ring for 7" Cylinder 570, 571
	12952	Protective Ring for 8" Cylinder B570, B571
20	08281	Label (Fire Ratings) - 570/B570
	10853	Label (Fire Ratings) - 571/B571

All Valve Assemblies include Valve Body, Gauge, Lever and Handle

* To replace old style hose use 10744 and 10800.



PARTS LIST for 50 lb. Dry Chemical Wheeled/Stationary Extinguisher Models

- 495 - 50 lb. ABC
- 496 - 50lb. REG
- 497 - 50lb. PK
- 473 - 50lb. ABC STA
- 474 - 50lb. REG STA
- 475 - 50lb. PK STA

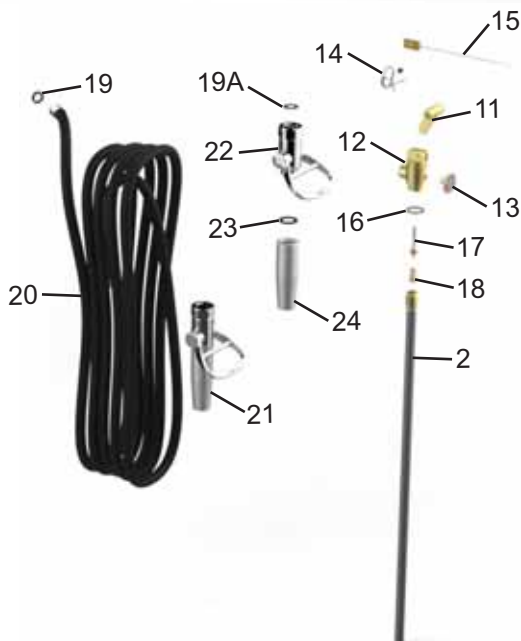

ITEM NO.	PART NO.	DESCRIPTION
1	06018	Valve Assembly Complete with Downtube
2	06072	Downtube/Retainer Assembly
3	06625	Carriage Assembly without Wheels
4	00155	Pressure Valve and Cap Assembly (Older Models Only)
5	06374	Hose Support with Hardware, Hose Clip and Nozzle Mount
6	06375	Hose Clip with Mounting Hardware (Older Models Only)
7	06376	Nozzle Mount with Hardware
8	07480	Pictogram - Model 495, 473
	07482	Pictogram - Models 496, 497, 474, 475
9	06377	Wheel Assembly 12½" with Hub Cap, Washer and Retaining Pin (Semi-Pneumatic)
10	04945	Hub Cap
11	06373	Valve Lever ("T" Handle - Complete)
12	06153	Valve Body
13	05225	Gauge - 240 PSI
14	06100	Ring Pin, Stainless Steel with Wire
15	01387	Lock Wire Seal (Yellow)
16	05240	Collar O-Ring
17	06022	Valve Stem Assembly
18	00383	Spring
19	07247	Gasket, Hose
19A	06056	Gasket Valve
20	06015	Hose Assembly 25 ft. with Gasket
21	06397	Nozzle Assembly (Ball Valve & Tip) - 495, 473
	06395	Nozzle Assembly (Ball Valve & Tip) - 496, 474
	06396	Nozzle Assembly (Ball Valve & Tip) - 497, 475
22	06031	Ball Valve Assembly
23	03877	Gasket, Nozzle
24	06208	Nozzle Tip - 495, 473 (.328)
	06032	Nozzle Tip - 496, 474 (.265)
	06210	Nozzle Tip - 497,475 (281)

Replacement Valve Assemblies include Valve Body, Gauge, Lever, Valve Stem Assembly, Spring and Downtube/Retainer Assembly



PARTS LIST for 125/150 lb. Dry Chemical Stored Pressure Wheeled/Stationary Extinguisher Models

488 - 125lb. ABC 476 - 125lb. ABC STA.
489 - 150lb. REG 477 - 150lb. REG STA.
490 - 125lb. PK 478 - 125lb. PK STA.

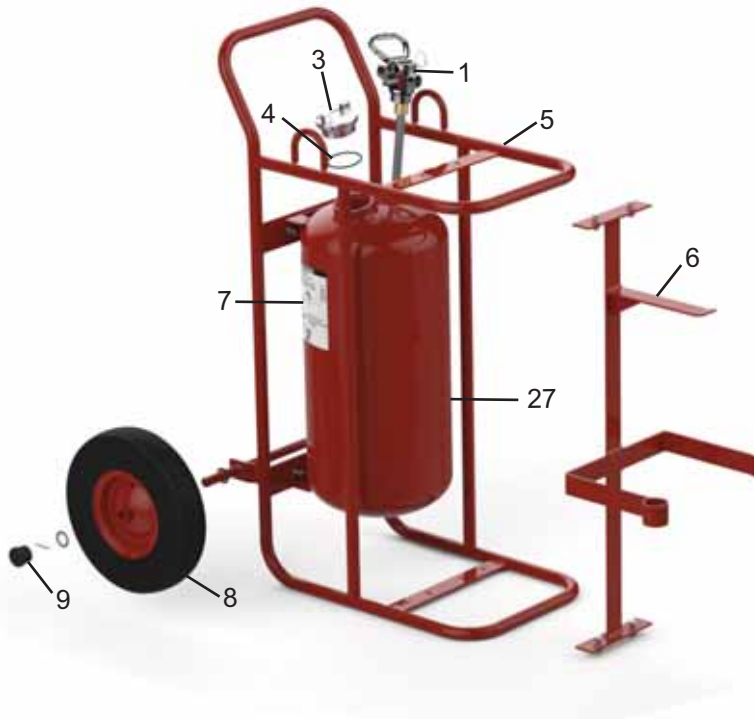

ITEM NO.	PART NO.	DESCRIPTION
1	05197	Valve Assembly Complete with Downtube
2	04938	Downtube/Retainer Assembly
3	09300	Fill Cap
4	08392	Gasket, Fill Cap
5	10431	Carriage Assembly without Wheels
6	10430	Hose Support with Hardware
7	07481	Pictogram - 488, 476
	07483	Pictogram - 489, 490, 477, 478
8	07751	Wheel Assembly 16" with Hub Cap, Washer and Retaining Pin (Semi-Pneumatic)
	10234	Wheel Assembly 16" with Hub Cap, Washer and Retaining Pin (Pneumatic) (OPTIONAL)
9	04945	Hub Cap
10	06059	Valve Lever with Screws
11	03562	Gauge Guard Assembly
12	05225	Gauge - 240 PSI
13	06100	Ring Pin, Stainless Steel with Wire
14	00155	Pressure Valve and Cap Assembly
15	01387	Lock Wire Seal (Yellow)
16	03678	Valve Body
17	06060	Cam Assembly with O-Rings
18	14218	Pipe Plug - For Safety Disc Port
	03787	Safety Disc Assembly (OPTIONAL)
19	05239	Collar O-Ring
20	05067	Valve Stem Assembly
21	03556	Spring
22	03501	Hose Assembly 50 ft. without Gasket
23	03877	Gasket, Hose and Nozzle
24	06279	Ball Valve Assembly
25	05191	Nozzle Assembly (Ball Valve & Tip) - 488, 489, 476, 477
	07432	Nozzle Assembly (Ball Valve & Tip) - 490, 478
26	06470	Nozzle Tip - 488, 489, 476, 477 (.344)
	06208	Nozzle Tip - 490, 478 (.328)
27	10467	Cylinder

Replacement Valve Assemblies include Valve Body, Gauge, Gauge Guard, Cam, Pressure Valve & Cap, Lever, Valve Stem Assembly, Spring, Downtube/Retainer Assembly



PARTS LIST

for

125/150 lb. Dry Chemical 110 CU. FT. Nitrogen Cylinder Wheeled/Stationary Extinguisher Models

16" WHEELS	36" WHEELS	STATIONARY
467 - 125lb. ABC	470 - 125lb. ABC	484 - 125lb. ABC
468 - 150lb. REG	471 - 150lb. REG	485 - 150lb. REG
469 - 125lb. PK	472 - 125lb. PK	486 - 125lb. PK

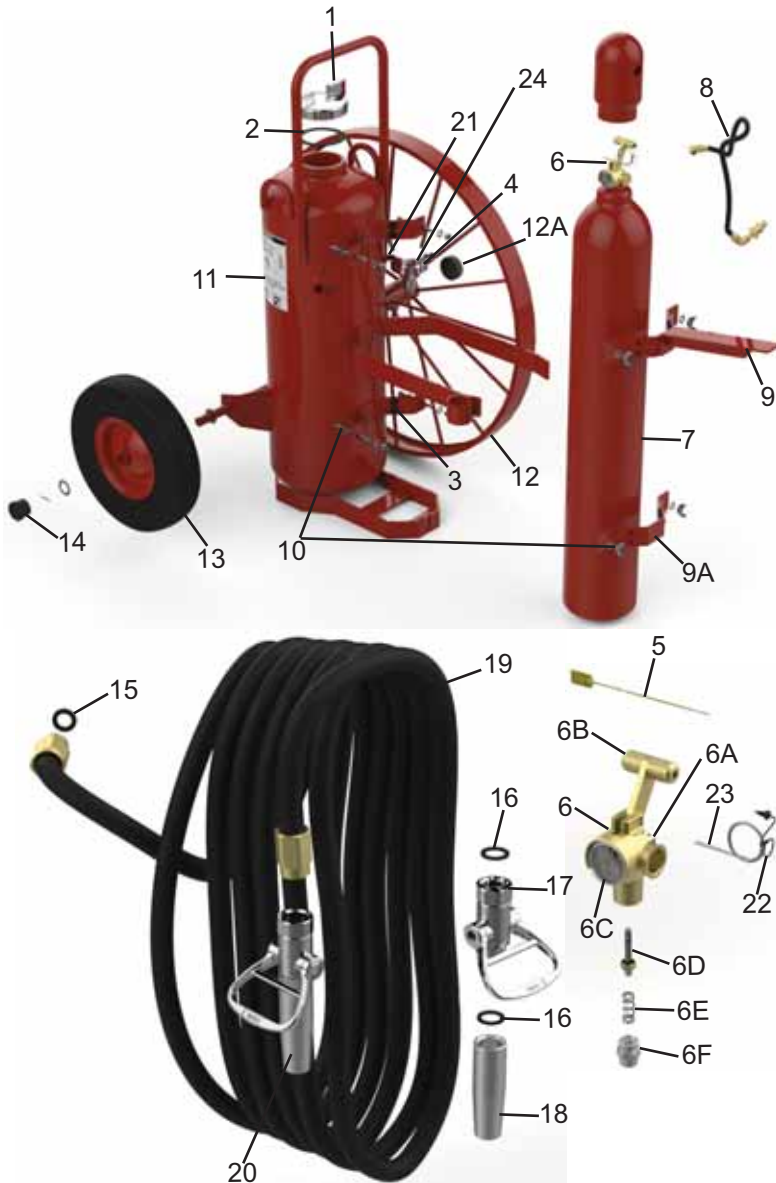

ITEM NO.	PART NO.	DESCRIPTION
1	06993	Cap, Agent Cylinder
	12576	Cap, Agent Cylinder with Pressure Indicator
2	02272	Gasket, Cap
3	13958	Bumper, Rubber
4	02235	Nitrogen Pressure Regulator
5	01387	Lock Wire Seal (Yellow)
6	12467	Nitrogen Valve with Gauge ("T" Handle Quick Release)
6A	16516	Safety Disc, Gasket and Nut Assembly
6B	06373	Valve Lever ("T" Handle - Complete)
6C	10213	Gauge - 3000 PSI
6D	09897	Valve Stem Assembly
6E	12466	Spring
6F	09627	Retainer
7	04128	Nitrogen Cylinder (110 cu. ft.) - Charged with Cap
8	02234	Nitrogen Hose Assembly
9	11024	Retaining Strap (Top) - Nitrogen Cylinder
9A	11021	Retaining Strap (Bottom) - Nitrogen Cylinder
10	16483	Bolt, Washer and Wing Nut
	07485	Pictogram - 467, 470, 485
11	07484	Pictogram - 468, 469, 471, 472, 486
	07025	Wheel Assembly - 36" x 2½"
12	07050	Wheel Assembly - 36" x 2½" with Rubber Tread
	12A	16984
13	07751	Wheel Assembly 16" with Hub Cap, Washer and Retaining Pin (Semi-Pneumatic)
	10234	Wheel Assembly 16" with Hub Cap, Washer and Retaining Pin (Pneumatic) (OPTIONAL)
14	04945	Hub Cap - 16" Wheels
15	07411	Moisture Seal
16	03877	Gasket, Hose and Nozzle
17	06279	Ball Valve Assembly
18	06032	Nozzle Tip (.265)
19	03501	Hose Assembly - 50 ft.
20	07574	Nozzle Assembly (Ball Valve & Tip)
21	04523	1/4 SS Pipe Nipple
22	00532	Chain (Nylon) for Ring Pin
23	00160	Ring Pin Stainless Steel
24	04444	1/4 MXF Elbow



PARTS LIST for 125/150 lb. Dry Chemical 23 CU. FT. Nitrogen Cylinder Wheeled/Stationary Extinguisher Models

450 - 125lb. ABC 481 - 125lb. ABC STA.
451 - 150lb. REG 482 - 150lb. REG STA.
452 - 125lb. PK 483 - 125lb. PK STA.
452OS - 125lb. PK

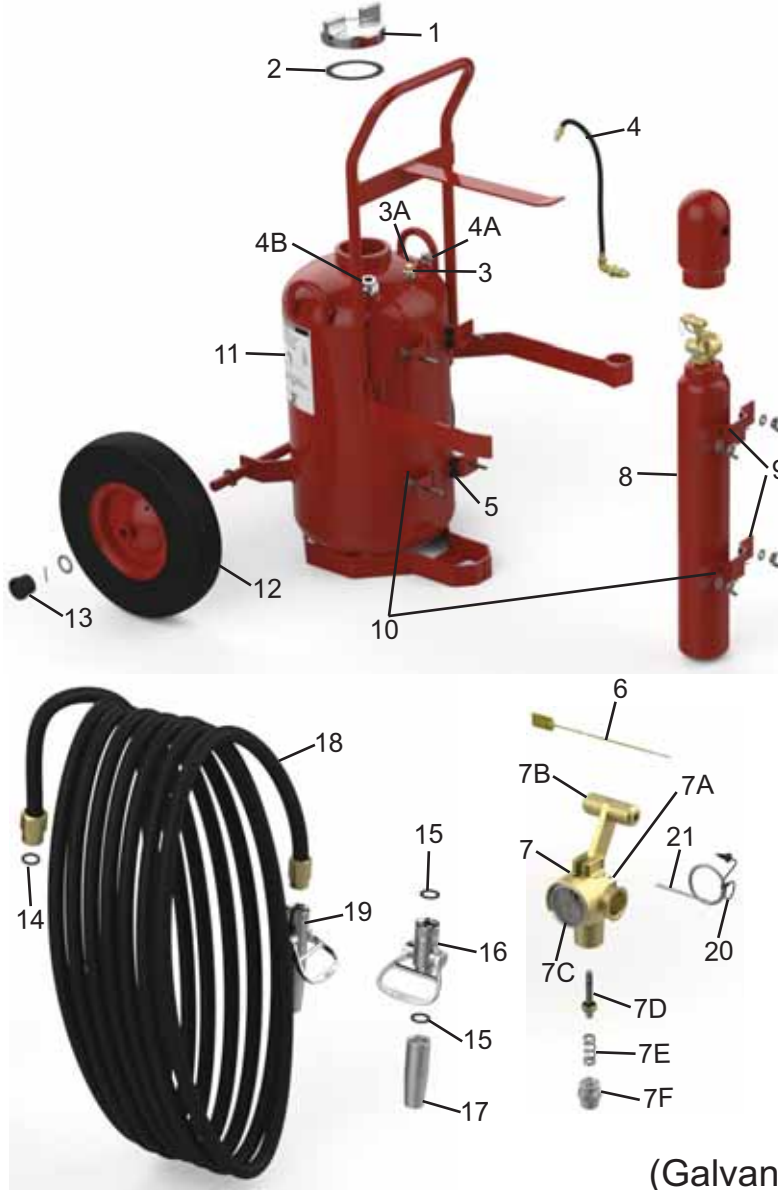

ITEM NO.	PART NO.	DESCRIPTION
1	06993	Cap, Agent Cylinder
	12576	Cap, Agent Cylinder with Pressure Indicator
2	02272	Gasket, Cap
3	03787	Safety Disc Assembly
3A	13956	Protective Vinyl Cap
4	03818	Nitrogen Hose Assembly
4A	03785	Nitrogen Tube Assembly
4B	03784	Downtube Assembly
5	13958	Bumper, Rubber
6	01387	Lock Wire Seal (Yellow)
7	12467	Nitrogen Valve with Gauge ("T" Handle Quick Release)
7A	16516	Safety Disc, Gasket and Nut Assembly
7B	06373	Valve Lever ("T" Handle - Complete)
7C	10213	Gauge - 3000 PSI
7D	09897	Valve Stem Assembly
7E	12466	Spring
7F	09627	Retainer
8	03817	Nitrogen Cylinder (23 cu. ft.) - Charged with Cap
9	04072	Retaining Strap - Nitrogen Cylinder
10	11970	Bolt, Washer and Wing Nut
	07485	Pictogram - 450, 481
11	07484	Pictogram - 451, 452, 452OS, 482, 483
	07751	Wheel Assembly 16" with Hub Cap, Washer and Retaining Pin (Semi-Pneumatic)
12	10234	Wheel Assembly 16" with Hub Cap, Washer and Retaining Pin (Pneumatic) (OPTIONAL)
	04945	Hub Cap - 16" Wheels
13	04945	Hub Cap - 16" Wheels
14	07411	Moisture Seal
15	03877	Gasket, Hose and Nozzle
16	06279	Ball Valve Assembly
17	06467	Nozzle Tip (.312)
18	03501	Hose Assembly - 50 ft.
19	06717	Nozzle Assembly (Ball Valve & Tip)
20	00532	Chain (Nylon) for Ring Pin
21	00160	Ring Pin Stainless Steel
22	23589	Support Hose Grd Assembly -452OS
23	23588	Support Hose Assembly -452OS
24	23587	Nozzel Mount Hose Grd Assembly -452OS

(Galvanized Models Only)

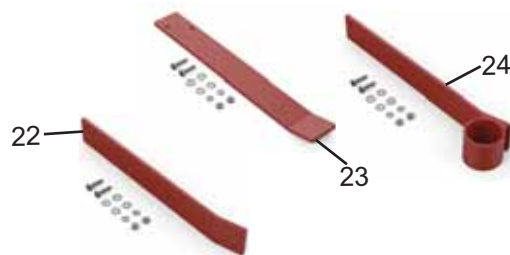



PARTS LIST for 300/350 lb. Dry Chemical 55 CU. FT. Nitrogen Cylinder Wheeled/Stationary Extinguisher Models

491 - 300lb. ABC 464 - 300lb. ABC STA.
 492 - 350lb. REG 465 - 350lb. REG STA.
 493 - 300lb. PK 466 - 300lb. PK STA.
 493OS - 300lb. PK

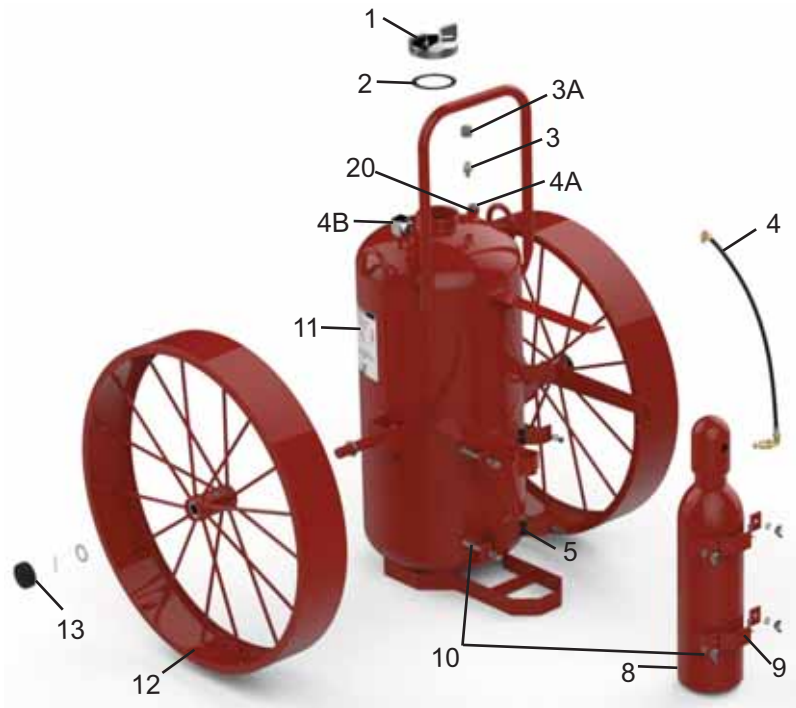

ITEM NO.	PART NO.	DESCRIPTION
1	06993	Cap, Agent Cylinder
	12576	Cap, Agent Cylinder with Pressure Indicator
2	02272	Gasket, Cap
3	03787	Safety Disc Assembly
3A	13956	Protective Vinyl Cap
4	07292	Nitrogen Hose Assembly
4A	06789	Nitrogen Tube Assembly
4B	06784	Downtube Assembly
	07575	Downtube Assembly (Vent Models)
5	13958	Bumper, Rubber
6	01387	Lock Wire Seal (Yellow)
7	12467	Nitrogen Valve with Gauge ("T" Handle Quick Release)
7A	16516	Safety Disc, Gasket and Nut Assembly
7B	06373	Valve Lever ("T" Handle - Complete)
7C	10213	Gauge - 3000 PSI
7D	09897	Valve Stem Assembly
7E	12466	Spring
7F	09627	Retainer
8	06809	Nitrogen Cylinder (55 cu. ft.) - Charged with Cap
9	11021	Retaining Strap - Nitrogen Cylinder
10	16483	Bolt, Washer and Wing Nut
11	07485	Pictogram - 491, 464
	07484	Pictogram - 492, 493, 493OS, 466
12	07026	Wheel Assembly 36" x 6" (Red)
	12180	Wheel Assembly 36" x 6" (Red) Glvanized
	15791	Wheel Assembly 36" x 6" (Red) Glvanized with Rubber Tread
	07607	Wheel Assembly 36" x 6" with Rubber Tread
13	07389	Hub Cap with Washer and Cotter Pin
14	07411	Moisture Seal
15	03877	Gasket, Hose and Nozzle
16	06279	Ball Valve Assembly
17	08260	Nozzle Tip - 491, 492, 464, 465(.531)
	08261	Nozzle Tip - 493, 493OS, 466 (.469)
18	06814	Hose Assembly - 50 ft.
	07760	Hose Assembly - 75 ft. (OPTIONAL)
19	07385	Nozzle Assembly (Ball Valve & Tip) - 491, 492, 464, 465
	07387	Nozzle Assembly (Ball Valve & Tip) - 493, 493OS, 466
20	04444	Nitrogen Elbow
21	00532	Chain (Nylon) for Ring Pin
22	00160	Ring Pin Stainless Steel
23	23589	Support Hose Grd Assembly - 493OS
24	23588	Support Hose Assembly - 493OS
25	23587	Nozzel Mount Hose Grd Assembly - 493OS

(Galvanized Models Only)

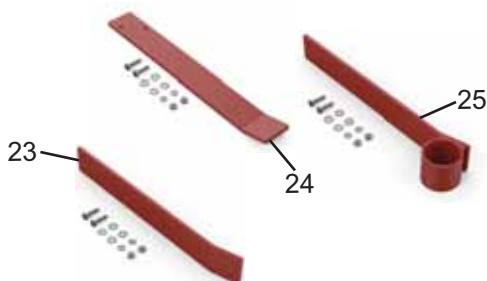



PARTS LIST for 125/250 lb. Dry Chemical Stored Pressure Wheeled/Stationary High Performance Extinguisher Models

573 - 250lb. ABC 596 - 250lb. ABC STA.
574 - 250lb. REG 597 - 250lb. REG STA.
575 - 250lb. PK 598 - 250lb. PK STA.
690 - 125lb. PK



ITEM NO.	PART NO.	DESCRIPTION
1	08715	Valve Assembly Complete with Downtube
	05197	Valve Assembly Complete with Downtube - 690
2	09856	Downtube/Retainer Assembly
	04938	Downtube/Retainer Assembly - 690
3	09300	Cap, Agent Cylinder
3A	08392	Gasket, Fill Cap
4	12176	Carriage Ass'y (Galvanized) w/o Wheels
	16786	Carriage Ass'y (Galvanized) w/o Wheels - 690
5	07481	Pictogram - 573, 596
	07483	Pictogram - 575, 574, 597, 598, 690
6	09553	Hose Support Ass'y w/ Mounting Hardware
	10430	Hose Support Ass'y w/ Mounting Hardware - 690
7	12180	Wheel Assembly 36" x 6" (Red) Galvanized
	15791	Wheel Assembly 36" x 6" (Red) Glvanized with Rubber Tread
8	07389	Hub Cap with Washer and Cotter Pin
9	06059	Valve Lever with Screws
10	16723	Gauge Guard Assembly
11	08714	Gauge - 350 PSI
	05225	Gauge - 240 PSI - 690
12	06100	Ring Pin, Stainless Steel with Wire
13	07309	Pressure Valve
	03559	Pressure Valve - 690
14	07310	Cap for Pressure Valve
	00158	Cap for Pressure Valve - 690
15	01387	Lock Wire Seal (Yellow)
16	06060	Cam Assembly with O-Rings
17	08573	Safety Disc Assembly (except 690)
	03787	Safety Disc Assembly (optional on 690)
	13956	Protective Vinyl Cap
	14218	Pipe Plug - 690
18	03678	Valve Body
19	05239	Collar O-Ring
20	05067	Valve Stem Assembly
21	03556	Spring
22	03877	Gasket, Hose / Nozzle
23	06279	Ball Valve Assembly
24	09399	Nozzle Tip - 573, 574, 596, 597 (.625)
	08260	Nozzle Tip - 575, 598, 690 (.531)
25	06814	Hose Assembly - 50 ft.
26	09543	Nozzle Assembly (Ball Valve & Tip) - 573, 574, 596, 597
	07385	Nozzle Assembly (Ball Valve & Tip) - 575, 598, 690
27	09711	Pistol Grip

NOTE: Replacement Valve Assemblies include Valve Body, Gauge, Gauge Guard, Safety Disc Assembly, Cam, Pressure Valve & Cap, Lever, Valve Stem Assembly, Spring and Downtube/Retainer Assembly (as required).



PARTS LIST

for
33 Gal. AR-AFFF Foam
23 CU. FT. Nitrogen Cylinder
Wheeled/Stationary
Extinguisher Models

630 - 33 gal. AR-AFFF
 631 - 33 gal. AR-AFFF STA.



ITEM NO.	PART NO.	DESCRIPTION
1	06993	Cap, Agent Cylinder
	12576	Cap, Agent Cylinder with Pressure Indicator
2	02272	Gasket, Cap
3	03787	Safety Disc Assembly - 630
	07665	Safety Disc Assembly - 631
3A	13956	Protective Vinyl Cap
4	02234	Nitrogen Hose Assembly
	06883	Nitrogen Tube Assembly
4A	06784	Downtube Assembly
5	13958	Bumper, Rubber
6	01387	Lock Wire Seal (Yellow)
7	12467	Nitrogen Valve with Gauge ("T" Handle Quick Release)
7A	16516	Safety Disc, Gasket and Nut Assembly
7B	06373	Valve Lever ("T" Handle - Complete)
7C	10213	Gauge - 3000 PSI
7D	09897	Valve Stem Assembly
7E	12466	Spring
7F	09627	Retainer
8	03817	Nitrogen Cylinder (23 cu. ft.) - Charged with Cap
9	04072	Retaining Strap - Nitrogen Cylinder
10	11970	Bolt, Washer and Wing Nut
11	07479	Pictogram - 630, 631
12	07026	Wheel Assembly 36" x 6"
	07607	Wheel Assembly 36" x 6" with Rubber Tread
13	07389	Hub Cap with Washer and Cotter Pin
14	06814	Hose Assembly - 50 ft.
15	07411	Moisture Seal
16	03877	Gasket, Hose and Nozzle
17	06279	Ball Valve Assembly
18	06749	Nozzle Tip (Aerated)
19	07560	Nozzle Assembly (Ball Valve & Tip)
20	04444	Nitrogen Elbow
21	00532	Chain (Nylon) for Ring Pin
22	00160	Ring Pin Stainless Steel



PARTS LIST for 50/100 lb. Carbon Dioxide Wheeled/Stationary Extinguisher Models

333 - 50lb.
334 - 100lb.
335 - 100lb. STA.

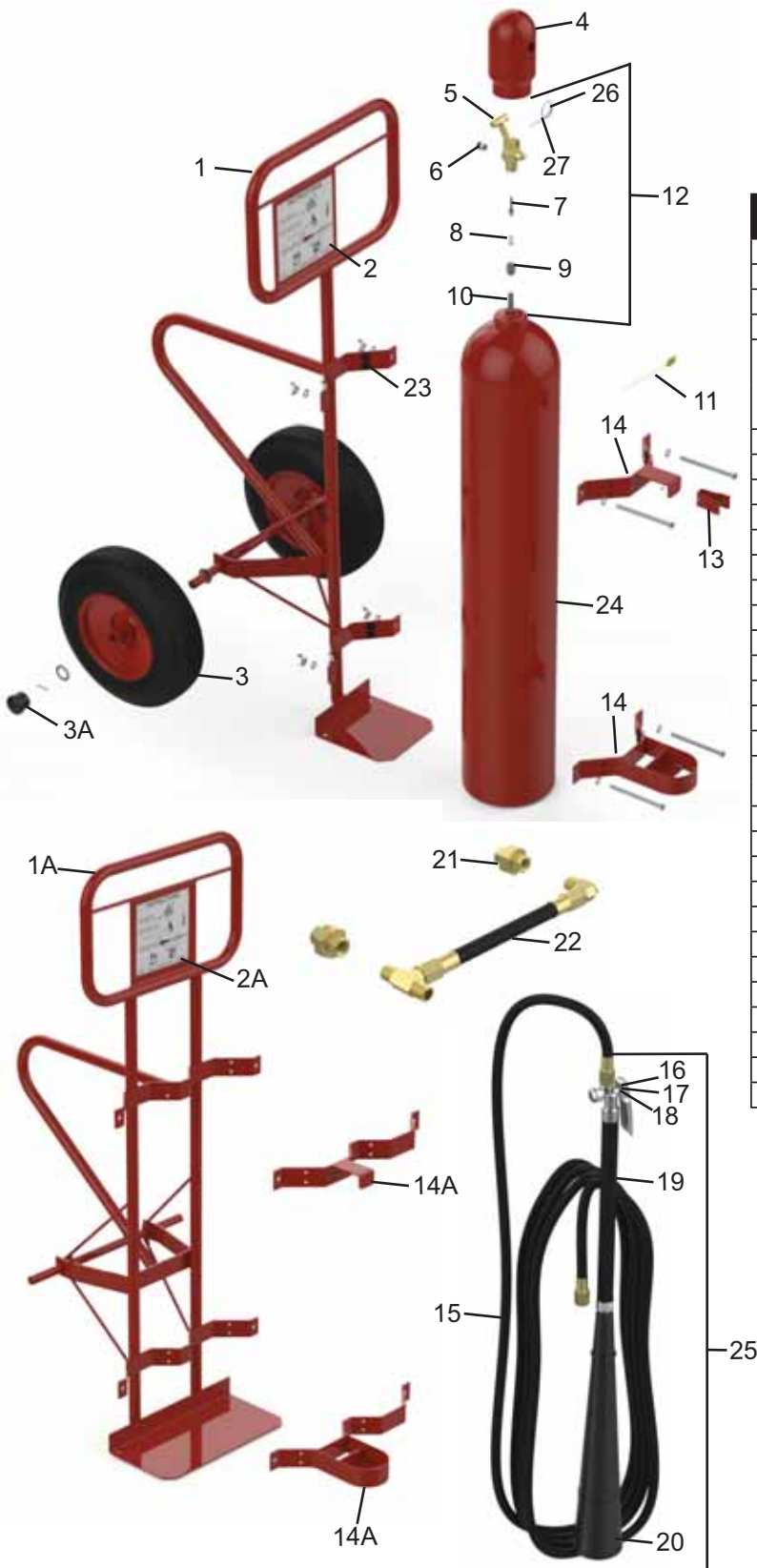

ITEM NO.	PART NO.	DESCRIPTION
1	09891	Carriage Assembly without Wheels - 333
1A	09903	Carriage Assembly without Wheels - 334
2	09618	Pictogram - 333
2A	09787	Pictogram - 334
3	10234	Wheel Assembly - 16" with Hub Cap, Washers and Cotter Pin - Full Pneumatic
	07751	Wheel Assembly - 16" with Hub Cap, Washers and Cotter Pin - Semi-Pneumatic
3A	04945	Hub Cap
4	12470	Cap - Valve Protector
5	06373	Valve Lever ("T" Handle - Complete)
6	04000	Safety Disc Assembly
7	09897	Valve Stem Assembly
8	00501	Spring
9	09627	Retainer
10	09623	Downtube
11	01387	Lock Wire Seal (Yellow)
12	09895	Valve Assembly Complete with Downtube
13	09892	Horn Clip with Mounting Hardware
14	09893	Saddles with Hardware - 333
14A	09904	Saddles with Hardware - 334
15	09365	Hose Assembly - 333 Older Models (15 ft.)
	09545	Hose Assembly - 333,334 (40 ft.)
16	09366	Shut-off Valve Assembly
17	09899	Valve Stem Assembly for Shut-off Valve
18	09901	Spring for Shut-off Valve
19	09896	Handle with Rubber Cover
20	09369	Horn & Nozzle
21	08169	Union (Manifold) - 334
22	09905	Manifold (with Unions) - 334
23	13958	Bumper, Rubber
24	10093	Cylinder Replacement CO2 - 50 lb.
25	09364	Horn and Valve Assembly
26	00532	Chain (Nylon) for Ring Pin
27	00160	Ring Pin Stainless Steel



PARTS LIST for 50/150 lb. Stored Pressure Wheeled/Stationary Halon 1211 Extinguisher Models

695 - 50lb. 600 - 150lb.
611 - 50lb. STA 610 - 150lb. STA

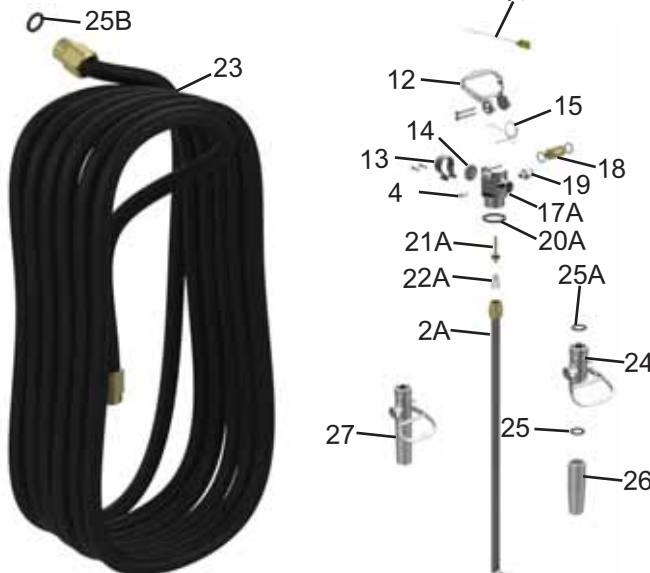
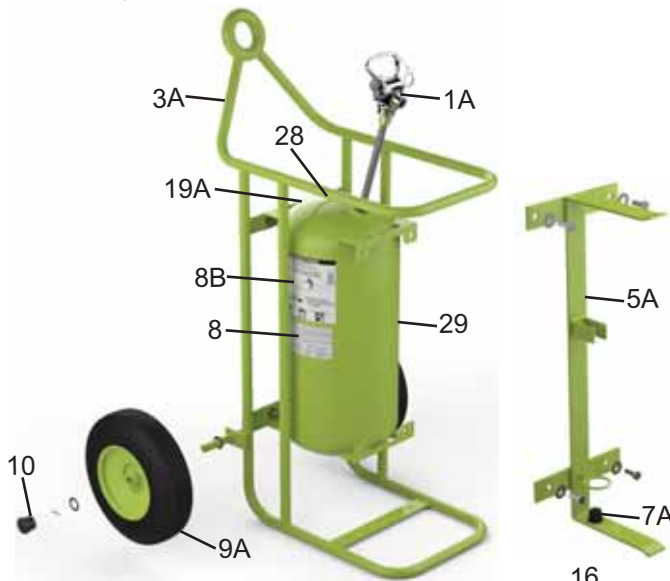
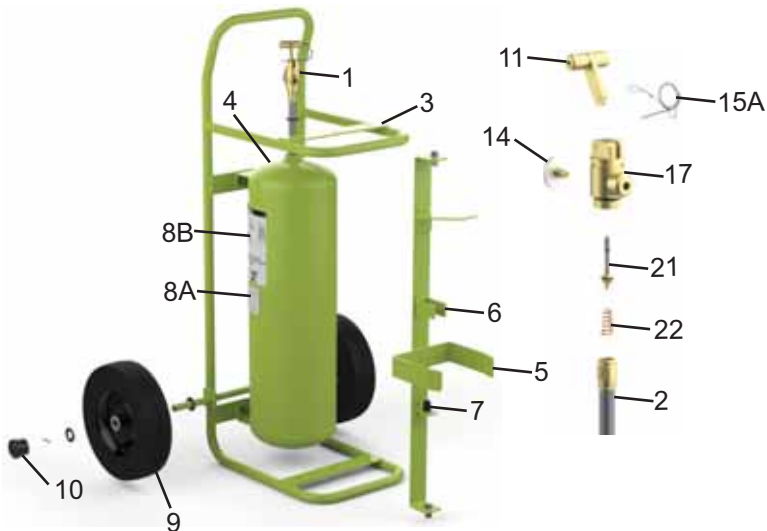

ITEM NO.	PART NO.	DESCRIPTION
1	06200	Valve Assembly Complete with Downtube - 695, 611
1A	03499	Valve Assembly Complete with Downtube - 600, 610
2	06072	Downtube/Retainer Assembly - 611, 695
2A	04938	Downtube/Retainer Assembly - 600, 610
3	06624	Carriage Assembly without Wheels - 695
3A	10523	Carriage Assembly without Wheels - 600
4	00155	Pressure Valve Assembly and Cap
5	06379	Hose Support with Mounting Hardware and Nozzle Mount - 611, 695
5A	06061	Hose Support with Mounting Hardware and Nozzle Mount - 600, 610
6	06380	Nozzle Clip with Hardware - 50lb. (Older Models)
7	06376	Nozzle Mount with Hardware - 695
7A	06130	Nozzle Mount with Hardware - 600
8	03624	Nameplate (Label) Non U/L - Model 600
8A	17111	Nameplate (Label) Non U/L - Model 695
8B	07480	Pictogram - 695, 611
8C	07481	Pictogram - 600, 610
9	06381	Wheel Assembly - 12 1/2" with Hub Cap, Washer and Retaining Pin - 695
9A	06062	Wheel Assembly - 16" with Hub Cap, Washer and Retaining Pin - Full Pneumatic - 600 (Green)
	07778	Wheel Assembly - 16" with Hub Cap, Washer and Retaining Pin - Semi-Pneumatic - 600
10	04945	Hub Cap - 695, 600
11	06373	Valve Lever ("T" Handle - Complete) - 695, 611
12	06059	Valve Lever with Screws - 600, 610
13	03562	Gauge Guard Assembly - 600, 610
14	03523	Gauge - 200 PSI - ALL
15	06100	Ring Pin, Stainless Steel with Wire - ALL
15A	00532	Chain (Nylon) for Ring Pin 695/611
	00160	Ring Pin Stainless Steel
16	01387	Lock Wire Seal (Yellow)
17	06153	Valve Body - 695, 611
17A	03678	Valve Body - 600, 610
18	06060	Cam Assembly with O-Rings - 600, 610
19	03787	Safety Disc Assembly - 600, 610
	13956	Protective Vinyl Cap
19A	05404	Decal Press VS. Temp. 600/610
20	05240	Collar O-Ring - 695, 611
20A	05239	Collar O-Ring - 600, 610
21	06022	Valve Stem Assembly - 695, 611
21A	05067	Valve Stem Assembly - 600, 610
22	00383	Spring - 695, 611
22A	03556	Spring - 600, 610
23	06015	Hose Assembly - 25 ft. with Gasket - 695, 611
	03501	Hose Assembly - 50 ft. - 600, 610
24	06031	Ball Valve Assembly - 695, 611
	06279	Ball Valve Assembly - 600, 610
25	03877	Gasket, Hose/Valve - 600, 610
25A	06056	Gasket, Valve - 695, 611
	03877	Gasket, Hose/Valve - 600, 610
25B	07247	Gasket, Hose - 695, 611
	03877	Gasket, Hose/Valve - 600, 610
26	06032	Nozzle Tip (.265) - 695, 611
	06355	Nozzle Tip (.375) - 600, 610
27	06395	Nozzle Assembly (Ball Valve & Tip) - 695, 611
27A	05295	Nozzle Assembly (Ball Valve & Tip) - 600, 610
28	06370	Plug, Pipe for Agent Level Indicator Hole - 600, 610 (Older Models)
29	03506	Cylinder

Replacement Valve Assemblies include New Valve Body, Gauge, (Gauge Guard, Safety Disc Assembly, Cam - Model 600, 610), Pressure Valve & Cap, Lever, Valve Stem Assembly, Spring and Downtube/Retainer Assembly



PARTS LIST

for

150/250 lb. Class D 110 CU. FT. Argon Cylinder Wheeled Extinguisher Models

680 - 150 lb. Sodium Chloride
681 - 250 lb. Copper

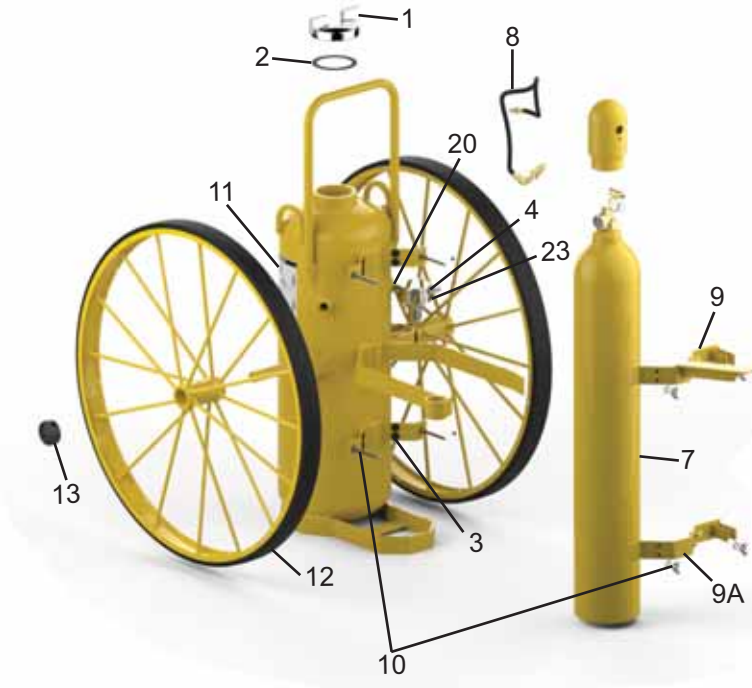

ITEM NO.	PART NO.	DESCRIPTION
1	06993	Cap, Agent Cylinder
	12576	Cap, Agent Cylinder with Pressure Indicator
2	02272	Gasket, Cap
3	13958	Bumper, Rubber
4	10915	Argon Pressure Regulator
5	01387	Lock Wire Seal (Yellow)
6	12467	Argon Valve with Gauge ("T" Handle Quick Release)
6A	16516	Safety Disc, Gasket and Nut Assembly
6B	06373	Valve Lever ("T" Handle - Complete)
6C	10213	Gauge - 3000 PSI
6D	09897	Valve Stem Assembly
6E	00501	Spring
6F	09627	Retainer
7	10904	Argon Cylinder (110 cu. ft.) - Charged with Cap
8	02234	Argon Hose Assembly
9	10906	Retaining Strap with Hose Hanger
9A	11020	Retaining Strap (Bottom) - Argon Cylinder
10	16483	Bolt, Washer and Wing Nut
11	10910	Pictogram - 680, 681
12	10917	Wheel Assembly - 36" x 2 1/2" with Rubber Tread
13	16984	Hub Cap - 36" Wheels
	07389	Hub Cap, Washer and Pin - 36" Wheels
14	03877	Gasket, Hose/Nozzle
15	06279	Ball Valve Assembly
16	06467	Nozzle Tip (.312) (OPTIONAL)
17	10913	Hose Assembly - 3/4" x 25 ft.
18	06717	Ball Valve Assembly
19	09740	Wand Applicator Assembly
20	04523	1/4" SS Pipe Nipple
21	00532	Chain (Nylon) for Ring Pin
22	00160	Ring Pin Stainless Steel
23	04444	1/4" MXF Elbow

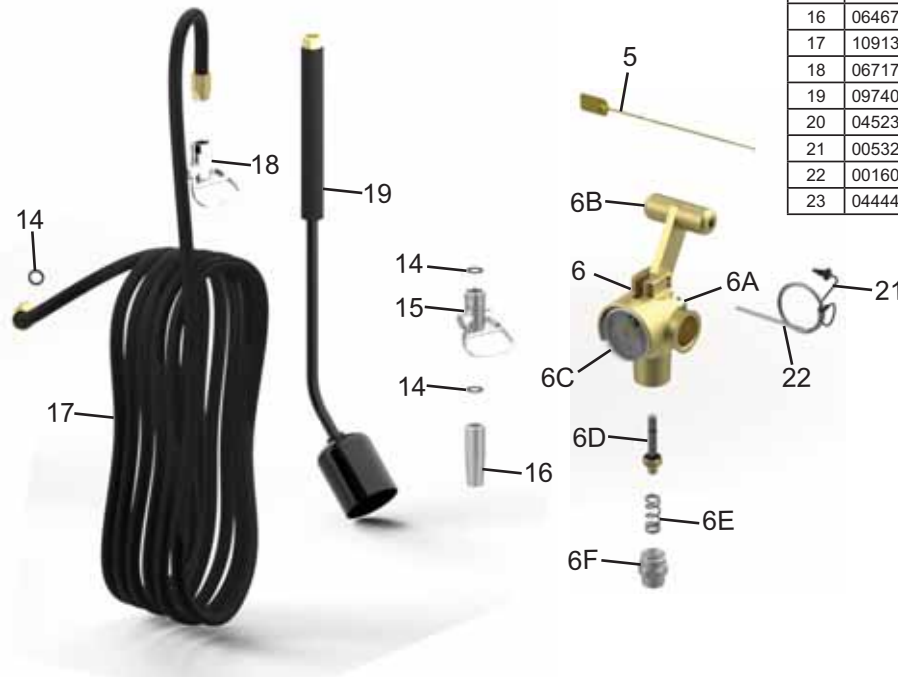



PARTS LIST for 65 lb. Stored Pressure Wheeled Halotron I Extinguisher Model

673



ITEM NO.	PART NO.	DESCRIPTION
1	16661	Valve Assembly Complete with Downtube
2	04938	Downtube/Retainer Assembly
3	16724	Carriage Assembly without Wheels
4	16690	Hose Support with Mounting Hardware
5	06130	Nozzle Mount with Hardware
6	07481	Pictogram
7	07751	Wheel Assembly - 16" with Hub Cap, Washer and Retaining Pin - Semi-Pneumatic
8	04945	Hub Cap
9	06059	Valve Lever with Screws
10	16723	Gauge Guard Assembly
11	14417	Gauge - 100 PSI
12	06100	Ring Pin, Stainless Steel with Wire
13	01387	Lock Wire Seal (Yellow)
14	16666	Valve Body
15	06060	Cam Assembly with O-Rings
16	16664	Collar O-Ring
17	16668	Valve Stem Assembly
18	03556	Spring
19	03501	Hose Assembly - 3/4" x 50'
20	06279	Ball Valve Assembly
21	03877	Gasket, Hose/Nozzle
22	16659	Nozzle Tip (.395)

Replacement Valve Assemblies include Valve Body, Gauge, Gauge Guard, Cam, Lever, Valve Stem Assembly, Spring and Downtube/Retainer Assembly





PARTS LIST for 150 lb. Stored Pressure Wheeled Halotron I Extinguisher Models

674 - 16" Semi-Pneumatic Galvanized Wheels
 675 - 36" x 6" Steel Wheels
 B674 - 16" Semi-Pneumatic Non-Galvanized Wheels
 B675 - 36" x 2 1/2" Steel w/ Rubber Tread Wheels

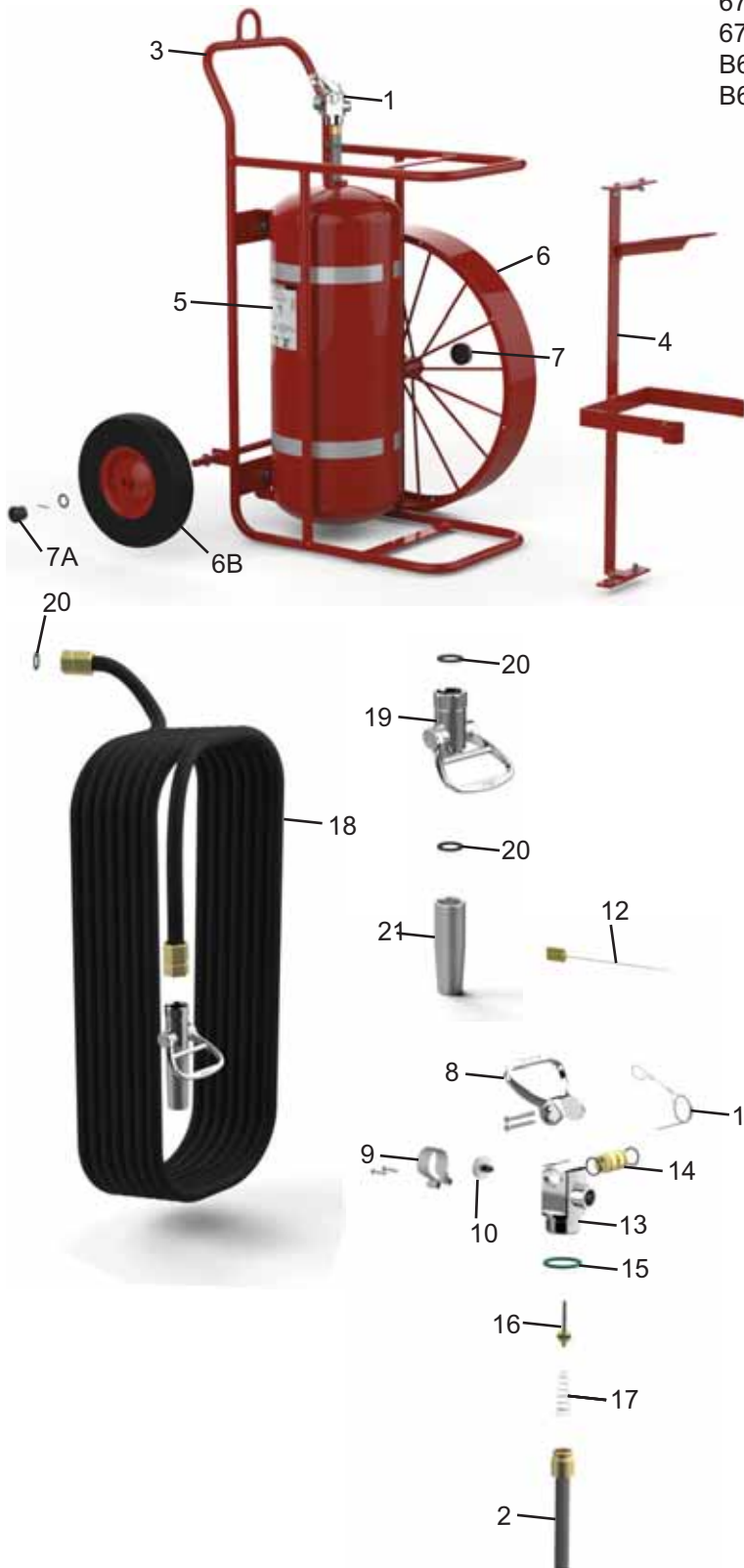

ITEM NO.	PART NO.	DESCRIPTION
1	16677	Valve Assembly Complete with Downtube 674, 675
	23808	Valve Assembly Complete with Downtube B674, B675
2	16726	Downtube/Retainer Assembly 674, 675
	23809	Downtube/Retainer Assembly B674, B675
3	16727	Carriage Assembly without Wheels 674
4	16725	Hose Support with Mounting Hardware
5	07481	Pictogram
6	07026	Wheel Assembly - 36" x 6" - 675 (Optional B675)
6A	07050	Wheel Assembly - 36" x 2 1/2" - B675 (Optional 675)
6B	07751	Wheel Assembly - 16" with Hub Cap, Washer and Retaining Pin - Semi-Pneumatic - Galvanized - 674 (Optional B674)
	23823	Wheel Assembly - 16" with Hub Cap, Washer and Retaining Pin - Semi-Pneumatic - Non-Galvanized - B674 (Optional 674)
7	16984	Hub Cap for 36" Wheels
	07389	Hub Cap for 36" Wheels with Washer and Cotter Pin
7A	04945	Hub Cap
8	06059	Valve Lever with Screws
9	16723	Gauge Guard Assembly
10	14418	Gauge - 125 PSI 674, 675
	16332	Gauge - 150 PSI B674, B675
11	06100	Ring Pin, Stainless Steel with Wire
12	01387	Lock Wire Seal (Yellow)
13	16666	Valve Body 674, 675
	22979	Valve Body B674, B675
14	06060	Cam Assembly with O-Rings
15	16664	Collar O-Ring
16	16668	Valve Stem Assembly 674, 675
	23811	Valve Stem Assembly B674, B675
17	16679	Spring 674, 675
	22983	Spring B674, B675
18	03501	Hose Assembly - 3/4" x 50'
19	06279	Ball Valve Assembly
20	03877	Gasket, Hose/Nozzle
21	16674	Nozzle Tip (.687) 674, 675
	23665	Nozzle Tip (.692) B674, B675

Replacement Valve Assemblies include Valve Body, Gauge, Gauge Guard, Cam, Lever, Valve Stem Assembly, Spring and Downtube/Retainer Assembly



(B Models Only)



PARTS LIST for 150lb. Stored Pressure Wheeled Novec 1230 Extinguisher Models

775 - 150lb. 16" Wheels

776 - 150lb. 36" Wheels

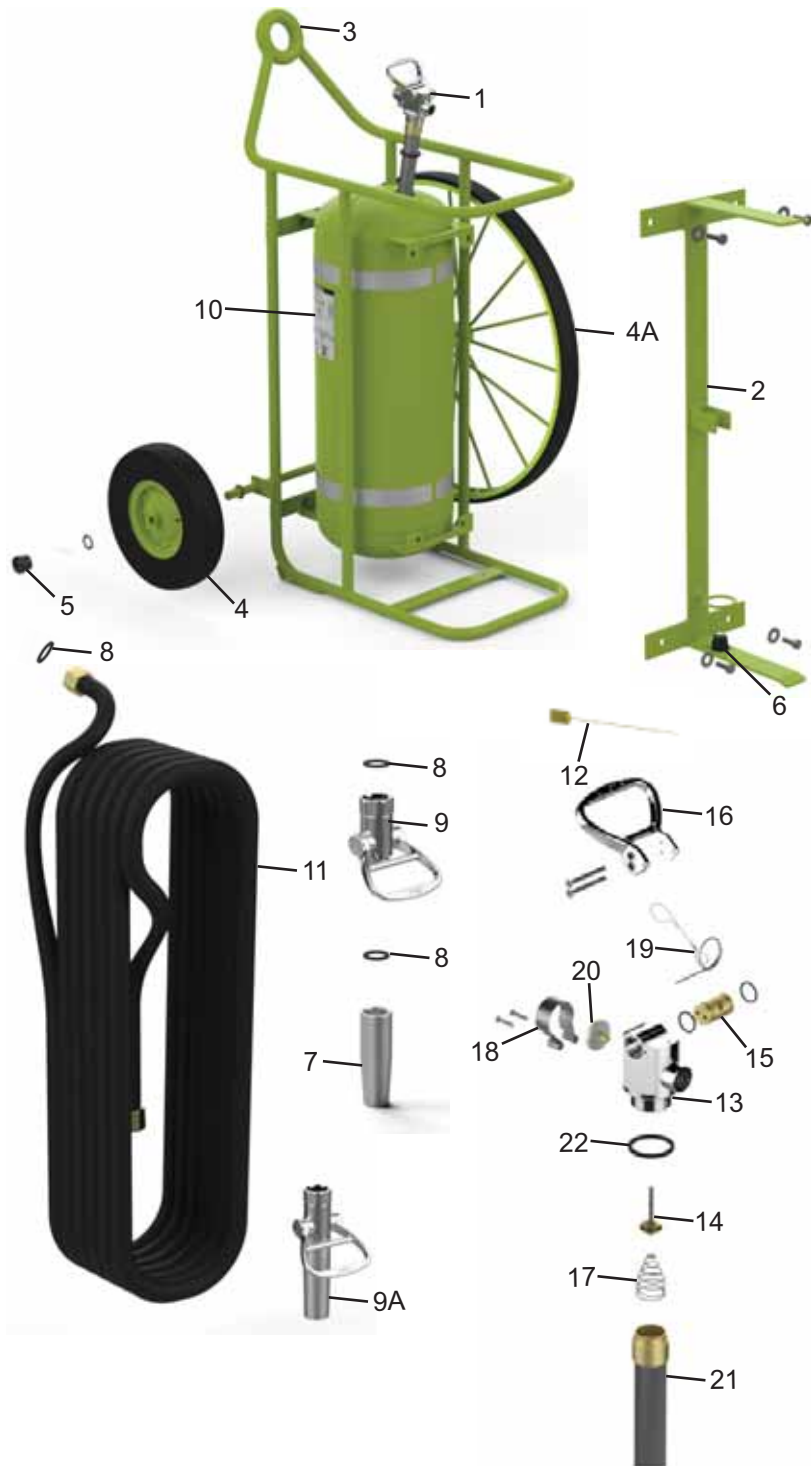

ITEM NO.	PART NO.	DESCRIPTION
1	22978	Valve Assembly 150 Novec
2	21941	Hose Support w/ Hardware
3	21920	Carriage Assembly 150 Novec GR 775
	23633	Carriage Assembly 150 Novec GR 776
4	06062	Wheel Assembly 16" Pneumatic w/ Hardware
	07778	Wheel Assembly 16" Semi-Pneumatic w/ Hardware
4A	23632	Wheel Assy 36" x 2.5 Steel w/ Hardware
5	04945	Hub Cap Black 16" Wheel
	16984	Hub Cap Black 36" Wheel
	07389	Hub Cap and Washer, Pin for 36" Wheel
6	06130	Mount Rubber w/ Hardware
7	19793	Nozzle Tip .531
8	03877	Gasket
9	06279	Ball Valve Assembly 150
9A	23634	Nozzle Assembly (Ball Valve and Tip) .531
10	07481	Pictogram
11	23544	Hose Assembly 1" x 40'
12	01387	Tamper Seal
13	22979	Valve Body
14	22984	Valve Stem Assembly
15	06060	Cam w/ Orings
16	06059	Valve Lever w/ Screws
17	22983	Valve Spring
18	16723	Gauge Guard Assembly
19	06100	Pull Pin and Wire
20	19789	Gauge 125 Novec
21	19787	Downtube Assembly
22	05239	Collar Oring

Replacement Valve Assemblies include Valve Body, Gauge, Gauge Guard, Lever, Valve Stem Assembly, Spring, Pull Pin/Wire and Downtube/Retainer Assembly



Adapters

Fill (Recharge) & Hydrotest (Cylinder & Hose)

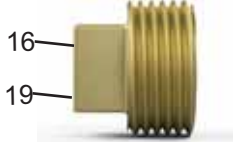
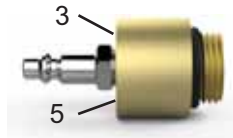
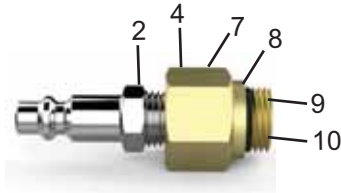

ITEM NO.	PART NO.	DESCRIPTION
Water, Water Mist, Wet Chemical & Foam Extinguishers		
1	03181	Hydrotest Adapter - 1"1/2" - UN
4*	02141	Fill Adapter - Hansen Quick Connect - 240, 250, 252, 254, 260, 262 - 5/8" - 18 UNF
6*	09492	Fill Adapter - Hansen Quick Connect - B270, B272, B260, B262 - 1/2" - 14 NPSL
Dry Chemical - Aluminum Valve Extinguishers		
2	01720	Fill Adapter - Hansen Quick Connect - 3/8"-24 UNF
3*	03610	Hydrotest Adapter - 1"-12 UNF
4*	02141	Fill Adapter - Hansen Quick Connect 5/8" - 18 UNF (20 lb. Aluminum Valve)
Dry Chemical - Brass Valve, High Performance, CL-D Extinguishers (Female Thread)		
4*	02141	Fill Adapter - Hansen Quick Connect 5/8" UNF
5*	03038	Hydrotest Adapter - 1 1/4"-12 UNF
6*	09492	Fill Adapter - High Performance Old style male thread - 1/2" - 14 NPSL
Halon 1211 - Aluminum Valve Extinguishers		
7	04485	Fill Adapter - Hansen Quick Connect - 3/8"-24 UNF
3*	03610	Hydrotest Adapter - 1"-12 UNF
Halon 1211 - Brass Valve Extinguishers		
8	04482	Fill Adapter - Hansen Quick Connect - 5/8" - 18 UNF
5*	03038	Hydrotest Adapter - 1 1/4"-12 UNF
Halotron I - Aluminum Valve Extinguishers		
9	14569	Fill Adapter - Snap Tite Quick Connect - 3/8"-24 UNF
3*	03610	Hydrotest Adapter - 1"-12 UNF
Halotron I - Brass Valve Extinguishers		
10	14568	Fill Adapter - Snap Tite Quick Connect - 5/8" - 18 UNF
5*	03038	Hydrotest Adapter - 1 1/4"-12 UNF
Carbon Dioxide - All CO2 Hand Portable Extinguishers		
11	01316	Fill Adapter - Hansen Quick Connect - 1/4" - 18 NPT, Installs on 2 1/2lb., 5lb. Discharge Tube - 3/8" - 18 - NPT with the Bushing removed, Install on 10lb., 15lb., 20lb. CO2 Elbow
12	01290	Hydrotest Adapter 1-1/8" - 12 UNF X 1/2" - 14 - NPT
Carbon Dioxide - Wheeled 50 lb. and 100 lb. Extinguishers		
13	09902	Fill Adapter - Hansen Quick Connect 1/2" - 14 NPT
14*	04892	Hydrotest Adapter 3/4" - 14 - NPT
Wheeled Stored Pressure - Dry Chemical, Halotron I and Halon 1211		
15*	06160	Fill Adapter - Hansen Quick Connect 50 lb. Dry Chemical and Halon 1211 3/4" - 11 1/2" NH
5*	03038	Hydrotest Adapter - 1 1/4"-12 UNF (50lb.)
16	06157	Hydrotest Adapter (Hose) (Male Plug) - Use with P/N: 6160 for 1/2" Hose Assembly 3/4" - 11 1/2" NH
17*	09857	Fill Adapter - 125, 150 & 250 lb. Dry Chemical 150 lb. Halon 1211, 65 lb., 150 lb. Halotron I and 150 lb. Novec 1" - 8NH
18*	05152	Hydrotest Adapter (Cylinder) - 125, 150 & 250 lb. Dry Chemical 150 lb. Halon 1211, 65 lb., 150 lb. Halotron I and 150 lb. Novec 2" - 8UN
19*	05723	Hydrotest Adapter (Hose) - Use with P/N: 9857 for 3/4" and 1" Hose Assembly 1" - 8NH
Wheeled Nitrogen or Argon Cylinder Operated - Gas Cylinder		
14*	04892	Hydrotest Adapter for Gas Cylinder 3/4" - 14NPT
Hose Hydrotest for Wheeled Dry Chemical, Foam, Halon, Halotron, Novec: For 1/2" Hose use 06160 Adapter and 06157 Plug. For 3/4" and 1" Hose use 09857 Adapter and 05723 Plug.		
* ADAPTER CAN BE USED ON MORE THAN ONE TYPE EXTINGUISHER		
Replacement Orings / Gaskets for Adapters		
PART NO.	DESCRIPTION	
01532	Oring for Item: 2, 7, 9	
06978	Oring for Item: 4, 8, 10	
05241	Oring for Item: 3	
05240	Oring for Item: 1, 5	
09494	Gasket for Item: 6	
01124	Oring for Item: 12	
06056	Gasket for Item: 15	
03877	Gasket for Item: 17	
05239	Oring for Item: 18	

RED LINE Model 5

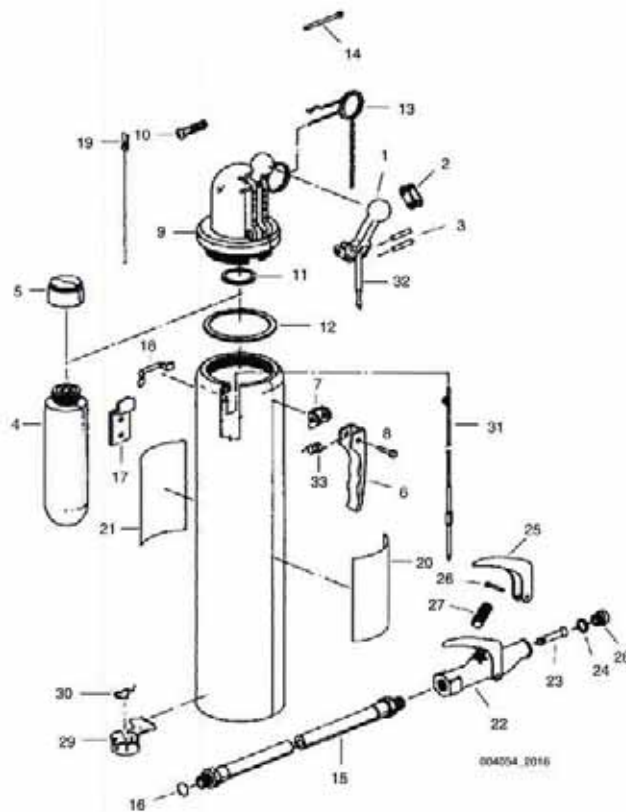

Fig. No.	Description	Part No.
1	Ball Lever without Puncture Pin	2330
2	Link, Ball Lever Assembly	1068
3	Rivets, Lever	1507
4	Cartridge Assembly w/Cap, CO2	4523
4	Cartridge Assembly w/Cap, Nitrogen, LT-5-R	6979
5	Cartridge Shipping Cap (LH)	77250
5	Cartridge Shipping Cap, LT (RH)	77251
6	Carrying Handle	6169
7	Carrying Handle Lug	N/A
8	Carrying Handle Rivet	1265
9	Dome and Fill Cap Assembly, Standard	2672
9	Dome and Fill Cap Assembly, LT	2759
10	Cap Screw	11318
11	Gasket, Cartridge Receiver	181
12	Gasket, Fill Cap	615
13	Ring Pin Assembly	2332
14	Rivet, Dome to Link	1506
15	Hose Assembly, 3/8 & 9/16 in. Couplings	15799
16	O-Ring	6263
17	Hanger Hook	2128
18	Hanger Attachment	N/A
19	Inspection Seal, Visual	15999
20	Nameplate, Operating, Replacement, 5, K-5	69563
20	Nameplate, Operating, Replacement, A-5	69564
21	Nameplate, Maintenance, Replacement w/o UL, 5, A-5, K-5	16440
22	Nozzle Assembly, Std & LT, PLUS-FIFTY C	6673
22	Nozzle Assembly, Std, FORAY	17519
22	Nozzle Assembly, Std, Purple-K	32130
22	Nozzle Assembly, LT, FORAY	17519
22	Nozzle Assembly, LT, Purple-K	10046
23	Plunger	4283
24	Gasket, Nozzle Tip	1662
25	Handle, Nozzle, Standard	2343
26	Rivet, Nozzle Handle	1048
27	Spring, Nozzle Handle	1666
28	Tip, Nozzle, Std, PLUS-FIFTY C	6612
28	Tip, Nozzle, Std, FORAY	69504
28	Tip, Nozzle, Std Purple-K, LT FORAY	4676
28	Tip, Nozzle, LT Purple-K	10047
29	Nozzle Holder	N/A
30	Spring, Nozzle Holder	7564
31	Gas Tube Assembly	10907
32	Puncture Pin	4287
33	Carry Handle Spring	2902

N/A -- Not Available

RED LINE Model 10-G

Fig. No.	Description	Part No.
1	Cartridge w/Cap, CO2, 10 (LH)	4616
1	Cartridge w/Cap, N2, LT-10 (RH)	13193
2	Cartridge Shipping Cap (LH)	77250
2	Cartridge Shipping Cap (RH)	77251
3	Cartridge Receiver (RH)	1356
3	Cartridge Receiver (LH)	3626
3	Cartridge Receiver, CR (LH)	17913
3	Cartridge Receiver Assembly, CR, LT (RH)	24449
4	Cap, Rubber	1057
5	Gasket, Cartridge Receiver	181
6	Link, Cartridge Receiver	1068
7	Puncture Lever	3628
8	Spring Pin, Link to Puncture Lever	4108
9	Spring Pin, Puncture Lever to Puncture Pin	4109
10	Puncture Pin	25305
11	Retaining Ring	1903
12	Rivet, Link to Cartridge Receiver	6286
13	Cartridge Guard, Composite, Std	418023
13	Cartridge Guard, Composite, LT	418024
14	Ring Pin Cartridge Guard, Composite	418243
14	Ring Pin Guard, Composite, LT-RP-10	428136
15	Ring Pin and Chain Assembly	7095
16	Rivet, RP to Guard	24156
17	Carrying Handle, Std	6169
17	Carrying Handle, CR	17902
18	Carrying Handle Rivet	1265
19	Carrying Handle Spring	2902
20	Fill Cap w/Indicator, Std	17999
20	Fill Cap w/Indicator, CR	422808
20	Fill Cap w/o Indicator, Std	32028
20	Fill Cap w/o Indicator, CR	17903
21	Gasket, Fill Cap	6190
22	Quad Ring, Fill Cap	6273
23	Cap, Plastic	17633
24	Stem, Indicator	27648
25	Quad Ring	17630
26	Retaining Ring	1239

Fig. No.	Description	Part No.
27	Hanger Hook	3651
28	Hose w/Couplings, Std	13005
28	Hose w/Couplings, CR	77739
29	O-Ring	6263
30	Inspection Seal, Visual	15999
31	"A" Nameplate, Operating, Replacement	69567
31	RP "A" Nameplate, Operating, Replacement	69570
31	"K"/"C" Nameplate, Operating, Replacement	69566
31	RP "K"/"C" Nameplate, Operating, Replacement	69569
33	Nameplate, Maintenance, Replacement w/o UL	416373
34	Nozzle Assembly, K-10, LT-K-10	30787
34	Nozzle Assembly, CR-K-10, CR-LT-K-10	54732
34	Nozzle Assembly, A-10, LT-A-10	31407
34	Nozzle Assembly, CR-A-10, CR-LT-A-10	53470
35	Nozzle Plunger	56117
36	O-Ring, Nozzle Assembly	3469
37	Rivet, Nozzle Handle	3621
38	Handle, Nozzle Assembly, Std	419389
38	Handle, Nozzle Assembly, CR	423461
39	Spring, Nozzle Handle	419422
41	Nozzle Tip, K-10	30788
41	Nozzle Tip, A-10	31502
41	Nozzle Tip, 10 PLUS-FIFTY C	56116
44	Gas Tube Assembly	434446
45	Hose Seal (Pkg of 30)	415659
46	Retaining Ring (Pkg of 50)	415855
-	Extinguisher Weather Cover (Not Shown)	67636
-	Hose Inspection Kit (Seal & Retaining Ring)	426687

CARTRIDGE-OPERATED FIRE EXTINGUISHERS

RED LINE Model 20-G

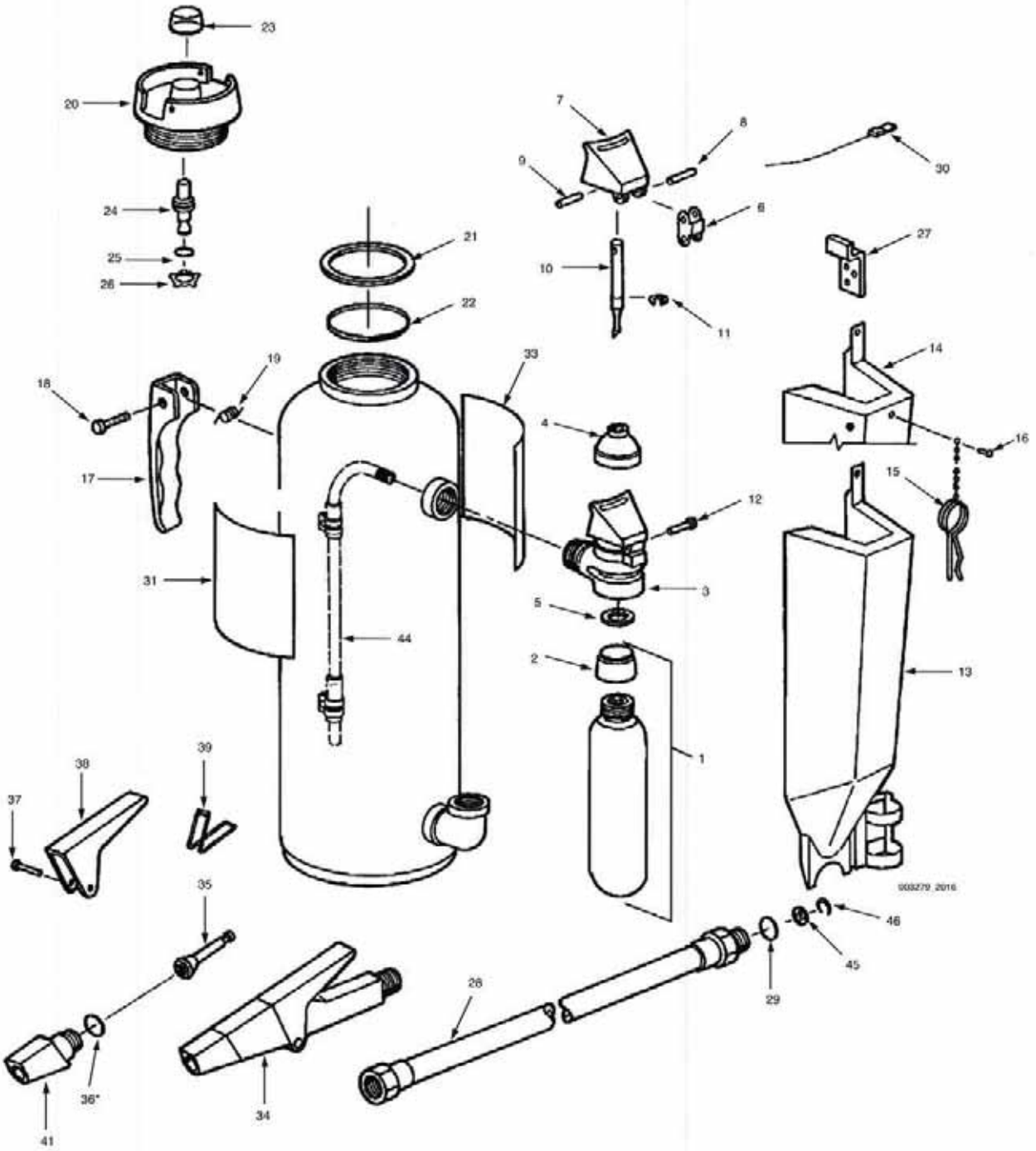

RED LINE Model 20-G

Fig. No.	Description	Part No.
1	Cartridge w/Cap, CO2, 20 (LH)	4614
1	Cartridge w/Cap, N2, LT-20 (RH)	7032
2	Cartridge Shipping Cap (LH)	77250
2	Cartridge Shipping Cap (RH)	77251
3	Cartridge Receiver (RH)	1356
3	Cartridge Receiver (LH)	3626
3	Cartridge Receiver, CR (LH)	17913
3	Cartridge Receiver Assembly, CR, LT (RH)	24449
4	Cap, Rubber	1057
5	Gasket, Cartridge Receiver	181
6	Link, Cartridge Receiver	1068
7	Puncture Lever, Std	3628
7	Puncture Lever, CR	17915
8	Spring Pin, Link to Puncture Lever	4108
9	Spring Pin, Puncture Lever to Puncture Pin	4109
10	Puncture Pin	25305
11	Retaining Ring	1903
12	Rivet, Link to Cartridge Receiver	6286
13	Cartridge Guard, Composite, Std	416346
13	Cartridge Guard, Composite, LT	416524
13	Cartridge Guard, Metal	426447
14	Ring Pin Cartridge Guard, Composite	416347
14	Ring Pin Cartridge Guard, Composite, LT-20	428137
14	Ring Pin Cartridge Guard, Metal	426450
15	Ring Pin and Chain Assembly	7095
16	Rivet, RP to Guard	24156
17	Carrying Handle, Std	6169
17	Carrying Handle, CR	17902
18	Carrying Handle Rivet	1265
19	Carrying Handle Spring	2902
20	Fill Cap w/Indicator, Std	17999
20	Fill Cap w/Indicator, CR	422808
21	Gasket, Fill Cap	6190
22	Quad Ring, Fill Cap	6273
23	Cap, Plastic	17633
24	Stem, Indicator	27648
25	Quad Ring	17630
26	Retaining Ring	1239

Fig. No.	Description	Part No.
27	Hanger Hook	3651
28	Hose w/Couplings, Std	7091
28	Hose w/Couplings, CR	24459
29	O-Ring	6323
30	Inspection Seal, Visual	15999
31	"A" Nameplate, Operating, Replacement	69567
31	RP "A" Nameplate, Operating, Replacement	69570
31	"K"/"C" Nameplate, Operating, Replacement	69566
31	RP "K"/"C" Nameplate, Operating, Replacement	69569
33	Nameplate, Maintenance, Replacement w/o UL	416374
34	Nozzle Assembly 20, LT-20, Std 20	30778
34	Nozzle Assembly 20, HF-A, HF-K	15156
34	Nozzle Assembly CR-20, CR-LT-20	30818
34	Nozzle Assembly K-20, LT-K-20, A-20, LT-A-20	30789
34	Nozzle Assembly CR-K-20, CR-LT-K-20, CR-A-20, CR-LT-A-20	30817
35	Nozzle Plunger Assembly	56117
36	O-Ring, Nozzle Assembly	3469
37	Rivet, Nozzle Handle	3621
38	Handle, Nozzle Assembly, Std	419389
38	Handle, Nozzle Assembly, CR	423461
38	Handle, Nozzle Assembly, HF	426629
39	Spring, Nozzle Handle	419422
41	Tip, Nozzle Assembly, A & K Std	30790
41	Tip, Nozzle Assembly 20, HF-A, HF-K	25780
41	Tip, Nozzle Assembly, PLUS-FIFTY C	30791
44	Gas Tube Assembly	6317
45	Hose Seal (Pkg of 30)	415660
46	Retaining Ring (Pkg of 50)	415856
-	Extinguisher Weather Cover (Not Shown)	67637
-	Gasket Kit (Quad, Flat Gasket, Hose O-Ring)	415877
-	Hose Inspection Kit (Seal, Retainer Clip)	426688

RED LINE Model 30-G

Fig. No.	Description	Part No.
1	Cartridge w/Cap, CO2, 30 (LH)	4615
1	Cartridge w/Cap, N2, LT-30 (RH)	5373
2	Cartridge Shipping Cap (LH)	77250
2	Cartridge Shipping Cap (RH)	77251
3	Cartridge Receiver (RH)	1356
3	Cartridge Receiver (LH)	3626
3	Cartridge Receiver, CR (LH)	17913
3	Cartridge Receiver Assembly, CR, LT (RH)	24449
4	Cap, Rubber	1057
5	Gasket, Cartridge Receiver	181
6	Link, Cartridge Receiver	1068
7	Puncture Lever, Std	3628
7	Puncture Lever, CR	17915
8	Spring Pin, Link to Puncture Lever	4108
9	Spring Pin, Puncture Lever to Puncture Pin	4109
10	Puncture Pin	25305
11	Retaining Ring	1903
12	Rivet, Link to Cartridge Receiver	6286
13	Cartridge Guard, Composite	418025
13	Cartridge Guard, Composite LT	418026
14	Ring Pin Cartridge Guard, Composite	418244
14	Ring Pin Cartridge Guard, Composite, LT-30	435256
15	Ring Pin and Chain Assembly	7095
16	Rivet, RP to Guard	24156
17	Carrying Handle, Standard	6169
17	Carrying Handle, CR	17902
18	Carrying Handle Rivet	1265
19	Carrying Handle Spring	2902
20	Fill Cap w/Indicator, Standard	17999
20	Fill Cap w/Indicator, CR	422808
21	Gasket, Fill Cap	6190
22	Quad Ring, Fill Cap	6273
23	Cap, Plastic	17633
24	Stem, Indicator	27648
25	Quad Ring	17630
26	Retaining Ring	1239
27	Hanger Hook	3651
28	Hose w/Couplings, Std	7083
28	Hose w/Couplings, CR	24451
29	O-Ring	6324

Fig. No.	Description	Part No.
30	Inspection Seal, Visual	15999
31	"A" Nameplate, Operating, Replacement	69567
31	RP "A" Nameplate, Operating, Replacement	69570
31	"K"/"C" Nameplate, Operating, Replacement	69566
31	RP "K"/"C" Nameplate, Operating, Replacement	69569
33	Nameplate, Maintenance, Replacement w/o UL	416375
34	Nozzle Assembly 30, K-30, A-30, LT-30, LT-K-30, LT-A-30	30778
34	Nozzle Assembly, CR-30, CR-K-30, CR-A-30, CR-LT-30, CR-LT-K-30, CR-LT-A-30	30818
34	Nozzle Assembly 30, HF-A, HF-K	15159
34	Nozzle Assembly, MET-L-X/LITH-X	30464
35	Nozzle Plunger	56117
36	O-Ring, Nozzle Assembly	3469
37	Rivet, Nozzle Handle	3621
38	Handle, Nozzle Assembly, Standard	419389
38	Handle, Nozzle Assembly, CR	423461
38	Handle, Nozzle Assembly, HF	426629
39	Spring, Nozzle Handle	419422
41	Nozzle Tip, MX/LX	25799
41	Tip, Nozzle Assembly, LT-K (Pre 2012)	17946
41	Tip, Nozzle Assembly, LT-A, MET-L-KYL (Pre 2012)	17932
41	Tip, Nozzle Assembly 30, HF-A, HF-K	25781
41	Tip, Nozzle Assembly, A & K Std, PLUS-FIFTY C	30791
41	Tip, Nozzle Assembly, MET-L-X, LITH-X	25799
41	Tip, Nozzle Assembly, All SPILL-X	30791
44	Gas Tube Assembly	434620
45	Hose Seal (Pkg of 30)	415661
46	Retaining Ring (Pkg of 50)	415857
-	Extinguisher Weather Cover (Not Shown)	67638
-	Gasket Kit (Quad Ring, Flat Gasket, Hose O-Ring)	415878
-	Hose Inspection Kit (Seal & Retainer Clip)	426689

RED LINE Model 10-E

Fig. No.	Description	Part No.
1	Cartridge w/Cap, CO2, 10 (LH)	4616
1	Cartridge w/Cap, N2, LT-10 (RH)	13193
2	Cartridge Shipping Cap (LH)	77250
2	Cartridge Shipping Cap (RH)	77251
3	Cartridge Receiver (RH)	1356
3	Cartridge Receiver (LH)	3626
3	Cartridge Receiver, CR (LH)	17913
3	Cartridge Receiver Assembly, CR, LT (RH)	24449
4	Cap, Rubber	1057
5	Gasket, Cartridge Receiver	181
6	Link, Cartridge Receiver	1068
7	Puncture Lever	3628
8	Spring Pin, Link to Puncture Lever	4108
9	Spring Pin, Puncture Lever to Puncture Pin	4109
10	Puncture Pin	25305
11	Retaining Ring	1903
12	Rivet, Link to Cartridge Receiver	6286
13	Cartridge Guard, Metal, Std	3652
13	Cartridge Guard, Metal, CR	53468
13	Cartridge Guard, Metal, LT	12997
14	Ring Pin Cartridge Guard, Metal	6330
14	Ring Pin Guard, Metal, CR-LT-RP-10	35604
15	Ring Pin and Chain Assembly	7095
16	Rivet, Cartridge Guard	6579
17	Carrying Handle, Std	6169
17	Carrying Handle, CR	17902
18	Carrying Handle Rivet	1265
19	Carrying Handle Spring	2902
20	Fill Cap w/Indicator, Std	17999
20	Fill Cap w/Indicator, CR	422808
20	Fill Cap w/o Indicator, Std	32028
20	Fill Cap w/o Indicator, CR	17903
21	Gasket, Fill Cap	6190
22	Quad Ring, Fill Cap	6273
23	Cap, Plastic	17633
24	Stem, Indicator	27648
25	Quad Ring	17630
26	Retaining Ring	1239

Fig. No.	Description	Part No.
27	Hanger Hook	3651
28	Hose w/Couplings, Std	13005
28	Hose w/Couplings, CR	77739
29	O-Ring	6283
30	Inspection Seal, Visual	15999
31	"A" Nameplate, Operating, Replacement	69567
31	RP "A" Nameplate, Operating, Replacement	69570
31	"K"/"C" Nameplate, Operating, Replacement	69566
31	RP "K"/"C" Nameplate, Operating, Replacement	69569
32	Label, Low Temperature	25167
33	Nameplate, Maintenance, Replacement w/o UL	416373
34	Nozzle Assembly, PLUS-FIFTY C Std	14048
34	Nozzle Assembly, A-10, LT-A-10	31407
34	Nozzle Assembly, K-10, LT-K-10	30787
34	Nozzle Assembly, CR-A-10, CR-LT-A-10	53470
34	Nozzle Assembly, CR-K-10, CR-LT-K-10	54732
35	Nozzle Plunger	56117
36	O-Ring, Nozzle Assembly	3469
37	Rivet, Nozzle Handle	3621
38	Handle, Nozzle Assembly, HF	N/A
39	Spring, Nozzle Handle	N/A
40	Caplug (2)	25154
41	Nozzle Tip, A-10 UL	31502
41	Nozzle Tip, A-10 ULC	56116
41	Nozzle Tip, K-10	30788
42	Nozzle Holder Assembly	74206
43	Nozzle Platform Screw (2)	14908
44	Gas Tube Assembly	434446
-	Extinguisher Weather Cover (Not Shown)	67636
-	Hose Inspection Kit (Seal & Retaining Ring)	426687

RED LINE Model 20-E

Fig. No.	Description	Part No.
1	Cartridge w/Cap, CO2, 20 (LH)	4614
1	Cartridge w/Cap, N2, LT-20 (RH)	7032
2	Cartridge Shipping Cap (LH)	77250
2	Cartridge Shipping Cap (RH)	77251
3	Cartridge Receiver (RH)	1356
3	Cartridge Receiver (LH)	3626
3	Cartridge Receiver, CR (LH)	17913
3	Cartridge Receiver Assembly, CR, LT (RH)	24449
4	Cap, Rubber	1057
5	Gasket, Cartridge Receiver	181
6	Link, Cartridge Receiver	1068
7	Puncture Lever, Std	3628
7	Puncture Lever, CR	17915
8	Spring Pin, Link to Puncture Lever	4108
9	Spring Pin, Puncture Lever to Puncture Pin	4109
10	Puncture Pin	25305
11	Retaining Ring	1903
12	Rivet, Link to Cartridge Receiver	6286
13	Cartridge Guard, Metal, Std	6302
13	Cartridge Guard, Metal, CR	17917
13	Cartridge Guard, Metal, LT	6967
14	Ring Pin Cartridge Guard, Metal	7097
14	Ring Pin Cartridge Guard, Metal, LT-20	32025
14	Ring Pin Cartridge Guard, Metal, CR-LT-20	436454
14	Ring Pin Cartridge Guard, Metal, CR-20	55764
15	Ring Pin and Chain Assembly	7095
16	Rivet, Cartridge Guard	6579
17	Carrying Handle, Std	6169
17	Carrying Handle, CR	17902
18	Carrying Handle Rivet	1265
19	Carrying Handle Spring	2902
20	Fill Cap w/Indicator, Std	17999
20	Fill Cap w/Indicator, CR	422808
20	Fill Cap w/o Indicator, Std	32028
20	Fill Cap w/o Indicator, CR	17903
21	Gasket, Fill Cap	6190
22	Quad Ring, Fill Cap	6273
23	Cap, Plastic	17633
24	Stem, Indicator	27648
25	Quad Ring	17630
26	Retaining Ring	1239

Fig. No.	Description	Part No.
27	Hanger Hook	3651
28	Hose w/Couplings, Std	7091
28	Hose w/Couplings, CR	24459
29	O-Ring	6323
30	Inspection Seal, Visual	15999
31	"A" Nameplate, Operating, Replacement	69567
31	RP "A" Nameplate, Operating, Replacement	69570
31	"K"/"C" Nameplate, Operating, Replacement	69566
31	RP "K"/"C" Nameplate, Operating, Replacement	69569
32	Label, Low Temperature	25167
33	Nameplate, Maintenance, Replacement w/o UL	416374
34	Nozzle Assembly, PLUS-FIFTY C Std	14551
34	Nozzle Assembly, LT-A	14382
34	Nozzle Assembly, HF-A, HF-K	15156
34	Nozzle Assembly, PLUS-FIFTY C, CR	17905
34	Nozzle Assembly, A & K/LT-K Std	30789
34	Nozzle Assembly, CR-A, CR-K, CR-LT-K	30817
35	Nozzle Plunger	56117
36	O-Ring, Nozzle Assembly	3469
37	Rivet, Nozzle Handle	3621
38	Handle, Nozzle Assembly, HF	N/A
39	Spring, Nozzle Handle	N/A
40	Caplug (2)	25154
41	Tip, Nozzle Assembly, LT-A/CR-LT-A	17932
41	Tip, Nozzle Assembly, LT-A, LT-K	25778
41	Tip, Nozzle Assembly, HF-A, HF-K	25780
41	Tip, Nozzle Assembly, PLUS-FIFTY C Std	17908
41	Tip, Nozzle Assembly, A & K Std	30790
42	Nozzle Holder Assembly	74206
43	Nozzle Platform Screw (2)	14908
44	Gas Tube Assembly	6317
-	Extinguisher Weather Cover (Not Shown)	67637
-	Gasket Kit (Quad, Flat Gasket, Hose O-Ring)	415877
-	Hose Inspection Kit (Seal, Retainer Ring)	426688

RED LINE Model 30-E

Fig. No.	Description	Part No.
1	Cartridge w/Cap, CO2, 30 (LH)	4615
1	Cartridge w/Cap, N2, LT-30 (RH)	5373
2	Cartridge Shipping Cap (LH)	77250
2	Cartridge Shipping Cap (RH)	77251
3	Cartridge Receiver (RH)	1356
3	Cartridge Receiver (LH)	3626
3	Cartridge Receiver, CR (LH)	17913
3	Cartridge Receiver Assembly, CR, LT (RH)	24449
4	Cap, Rubber	1057
5	Gasket, Cartridge Receiver	181
6	Link, Cartridge Receiver	1068
7	Puncture Lever, Std	3628
7	Puncture Lever, CR	17915
8	Spring Pin, Link to Puncture Lever	4108
9	Spring Pin, Puncture Lever to Puncture Pin	4109
10	Puncture Pin	25305
11	Retaining Ring	1903
12	Rivet, Link to Cartridge Receiver	6286
13	Cartridge Guard, Metal, Std	6287
13	Cartridge Guard, Metal, CR	17938
13	Cartridge Guard, Metal, LT	6971
13	Cartridge Guard, Metal, MET-L-X, LITH-X	426455
13	Cartridge Guard, Metal, MET-L-KYL	426455
14	Ring Pin Cartridge Guard, Metal	7207
14	Ring Pin Cartridge Guard, Metal, CR-30	56986
15	Ring Pin and Chain Assembly	7095
16	Rivet, Cartridge Guard	6579
17	Carrying Handle, Standard	6169
17	Carrying Handle, CR	17902
18	Carrying Handle Rivet	1285
19	Carrying Handle Spring	2902
20	Fill Cap w/Indicator, Standard	17999
20	Fill Cap w/Indicator, CR	422808
20	Fill Cap w/o Indicator, Standard	32028
20	Fill Cap w/o Indicator, CR	17903
21	Gasket, Fill Cap	6190
22	Quad Ring, Fill Cap	6273
23	Cap, Plastic	17633
24	Stern, Indicator	27648
25	Quad Ring	17630
26	Retaining Ring	1239
27	Hanger Hook	3651

Fig. No.	Description	Part No.
28	Hose w/Couplings, Std	7083
28	Hose w/Couplings, CR	24451
29	O-Ring	6324
30	Inspection Seal, Visual	15999
31	"A" Nameplate, Operating, Replacement	69567
31	RP "A" Nameplate, Operating, Replacement	69570
31	"K"/"C" Nameplate, Operating, Replacement	69566
31	RP "K"/"C" Nameplate, Operating, Replacement	69569
31	MX-30-E/G Maintenance Nameplate	422613
31	LX-30-E/G Maintenance Nameplate	418178
31	ML-30-E/G Maintenance Nameplate	418179
31	MX-30-E/G Operating Nameplate	6459
31	LX-30-E/G Operating Nameplate	10039
31	ML-30-E/G Operating Nameplate	10038
32	Label, Low Temperature	25167
33	Nameplate, Maintenance, Replacement w/o UL	416375
34	Nozzle Assembly, LT-A, MET-L-KYL	14045
34	Nozzle Assembly, LT-K	14047
34	Nozzle Assembly, HF-A, HF-K	15159
34	Nozzle Assembly, PLUS-FIFTY C, LT	14706
34	Nozzle Assembly, PLUS-FIFTY C, CR	17931
34	Nozzle Assembly, A & K Std	30778
34	Nozzle Assembly, CR-A, CR-K	30818
34	Nozzle Assembly, MET-L-X, LITH-X	30464
35	Nozzle Plunger	56117
36	O-Ring, Nozzle Assembly	3469
37	Rivet, Nozzle Handle	3621
39	Spring, Nozzle Handle	N/A
38	Handle, Nozzle Assembly, HF	N/A
40	Caplug (2)	25154
41	Tip, Nozzle Assembly, LT-K	17946
41	Tip, Nozzle Assembly, HF-A, HF-K	25781
41	Tip, Nozzle Assembly, LT-A, MET-L-KYL	17932
41	Tip, Nozzle Assembly, A & K Std	30791
41	Nozzle Assembly, MET-L-X, LITH-X	25799
42	Nozzle Holder Assembly	74206
43	Nozzle Platform Screw (2)	14908
44	Gas Tube Assembly	434620
-	Extinguisher Weather Cover (Not Shown)	67638
-	Gasket Kit (Quad Ring, Flat Gasket, Hose O-Ring)	415878
-	Hose Inspection Kit (Seal & Retainer Clip)	426689

SENTRY Dry Chemical Models A02, A02VB, A02S, A02SVB, C02

Fig. No.	Description	Part No.
—	Valve Assembly, A02, A02VB, C02VB (with tube)	N/A
—	Valve Assembly, A02S, A02SVB (with tube)	436890
1	Valve Body Assembly, A02	433458
1	Valve Body Assembly, A02S	436604
2	Tube, Pick-up, A02	436841
2	Tube, Pick-up, A02S	436758
3	O-Ring (Pick-up Tube)	76076
4	Valve Stem Assembly	429099
5	O-Ring	11873
6	Spring	415565
7	O-Ring	428327
8	Gauge, Pressure, A02	56776
8	Gauge, 125 psi, A02S	436610
9	Lever, Operating, A02	429096
9	Lever, A02S (Aluminum)	436606
10	Handle, Carrying, A02	429097
10	Handle, A02S (Aluminum)	436607
11	Rivet, Operating Lever, A02	428130
11	Rivet, A02S	436608
12	Rivet, Carrying Handle	428130
13	Pull Pin (Ring Pin)	434211
13	Pull Pin (Ring Pin), Stainless Steel	436609
14	Seal, Visual Inspection	25940
15	Nozzle Tip Assembly, A02, A02VB, A02S, A02SVB, Aluminum	442405
15	Nozzle Tip Assembly, C02	428270
16	Hanger Hook, A02, A02S	21873
17	Bracket Assembly, A02VB, A02SVB	24610
18	Nameplate, Replacement w/o UL/ULC A02	430852
18	Nameplate, Replacement w/o UL/ULC A02S	440961
19	Recharge Adaptor, Combination, 02S, 02, 5/10/20	440623
20	O-Ring	57744
21	Tube Adaptor, A02S	436611
21	Tube Adaptor, A02	428124
—	Refill Agent, FORAY	53080

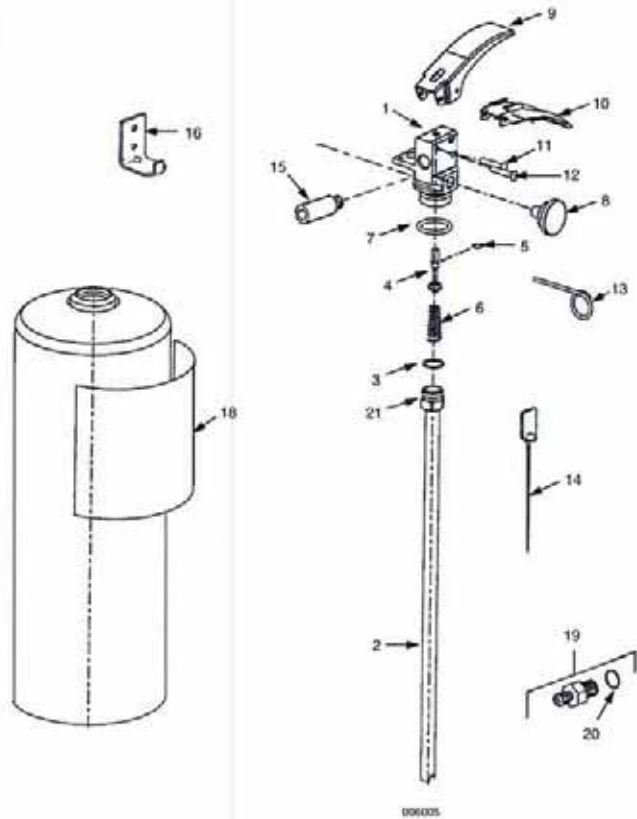

SENTRY Dry Chemical Models A05, A05VB, AA05, AA05VB, AA05-1, AA05-1VB, A05S, A05SVB, AA05S-1, AA05S-1VB, PK05, PK05S, C05

Fig. No.	Description	Part No.
—	Valve Assembly	N/A
1	Valve Body Assembly	433458
1	Valve Body Assembly, A05S	442365
2	Tube, Pick-Up	436842
2	Tube, Pick-Up, A05S	442367
3	O-Ring (Pick-up Tube)	76076
4	Valve Stem Assembly	429099
5	O-Ring	11873
6	Spring	415565
7	O-Ring	428327
8	Gauge, Pressure	56776
9	Lever, Operating	429096
10	Handle, Carrying	429097
11	Rivet, Operating Lever	428130
12	Rivet, Carrying Handle	428130
13	Pull Pin (Ring Pin), Large Loop	434211
14	Seal, Visual Inspection	25940
15	Hose & Nozzle Assy, A05, A05VB	428728
15	Hose & Nozzle Assy, AA05, AA05VB	428729
15	Hose & Nozzle Assy, A05S, A05SVB	442350
15	Hose & Nozzle Assy, AA05-1, AA05-1VB	434908
15	Hose & Nozzle Assy, AA05S-1, AA05S-1VB	442354
15	Hose & Nozzle Assy, PK05	428730
15	Hose & Nozzle Assy, PK05S	442351
15	Hose & Nozzle Assy, C05	428731
16	Hanger Hook, AA05, AA05-1, A05, C05, A05S, AA05S-1, PK05, PK05S	54405
17	Bracket Assy (Not Shown), AA05VB, AA05-1VB, A05VB, A05SVB, AA05S-1VB	429146
18	Nameplate, Replacement w/o UL/ULC, A05, A05VB	430853
18	Nameplate, Replacement w/o UL/ULC, A05S, A05SVB	442284
18	Nameplate, Replacement w/o UL/ULC, AA05, AA05VB	430854
18	Nameplate, Replacement w/o UL/ULC, AA05S-1, AA05S-1VB	440636
18	Nameplate, Replacement w/o UL/ULC, PK05S	440638
19	Adaptor, Recharge Combination	440623
20	O-Ring	57744
21	Hose Retainer	427995
—	Refill Agent, A05, A05VB, A05S, A05SVB	53080
—	Refill Agent, AA05, AA05VB	415788
—	Refill Agent, AA05-1, AA05-1VB, AA05S-1, AA05S-1VB	434906
—	Refill Agent, PK05, PK05S	9335
—	Refill Agent, C05	9336

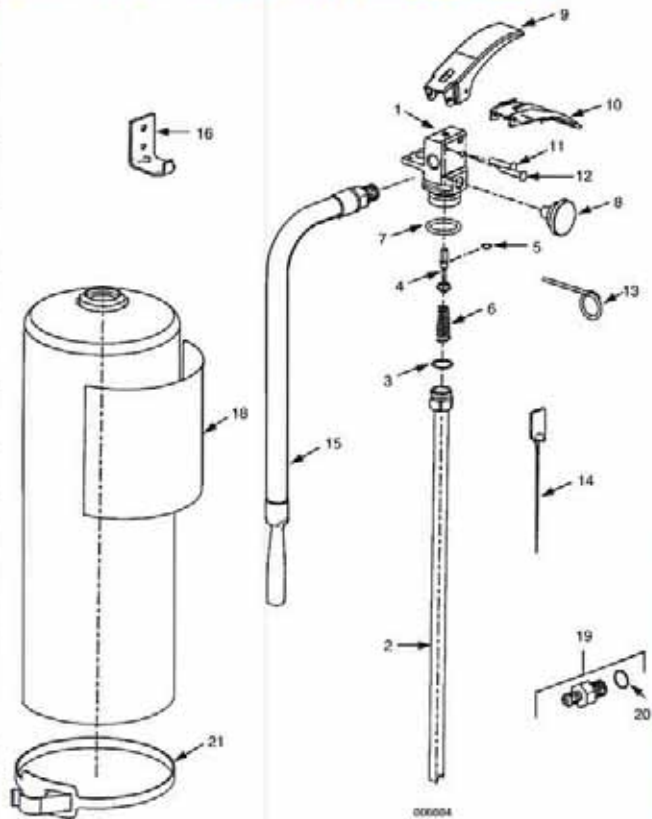

STORED PRESSURE FIRE EXTINGUISHERS

SENTRY Dry Chemical Models A10T, A10H, AA10S, PK10, PK10S, C10, C10S, AA20, AA20-1, PK20, C20

Fig. No.	Description	Part No.
—	Valve Assembly, 10S Models (w/tube)	436595
—	Valve Assembly, 10 lb Models except A10T (w/tube)	429085
—	Valve Assembly, A10T (w/tube)	429086
—	Valve Assembly, 20 lb Models (w/tube)	429087
1	Valve Body Assembly	433458
2	Tube, Pick-up, 10 lb Models except A10T/10S	436843
2	Tube, Pick-up, A10T	436844
2	Tube, Pick-up, 10S	437091
2	Tube, Pick-up, 20 lb Models	436845
3	O-Ring (Pick-up Tube)	76076
4	Valve Stem Assembly	429099
5	O-Ring	11873
6	Spring	415565
7	O-Ring	428327
8	Gauge, Pressure	56776
9	Lever, Operating	429096
10	Handle, Carrying	429097
11	Rivet, Operating Lever	428130
12	Rivet, Carrying Handle	428130
13	Ring Pin, Large Loop	434211
14	Seal, Visual Inspection	25940
15	Hose & Nozzle Assy, AA10S	436592
15	Hose & Nozzle Assy, A10T, A10H, C10, C10S	428732
15	Hose & Nozzle Assembly, PK10, PK10S	428734
15	Hose & Nozzle Assembly, AA20	428736
15	Hose & Nozzle Assembly, PK20	428738
15	Hose & Nozzle Assembly, C20	428740
16	Hose Retainer	427995
17	Hanger Hook (10H)	428223
17	Hanger Hook (10S)	428222
17	Hanger Hook (AA20)	428224
18	Nameplate, Oper & Maint w/o UL/ULC A10H	430855
18	Nameplate, Replacement w/o UL/ULC PK10S	440963
18	Nameplate, Replacement w/o UL/ULC PK20	440639
18	Nameplate, Replacement w/o UL/ULC AA10S	440640
18	Nameplate, Replacement w/o UL/ULC AA20	430857
18	Nameplate, Replacement w/o UL/ULC AA20-1	440964

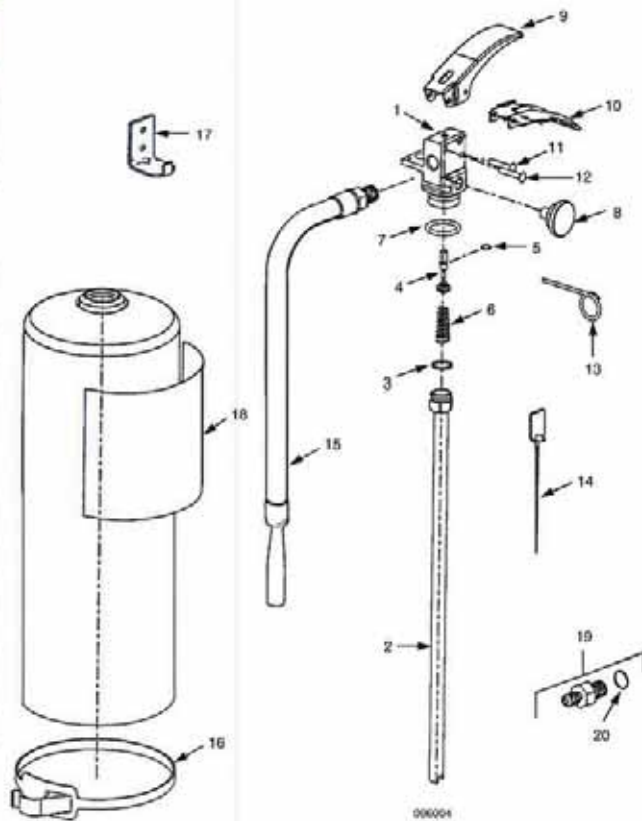
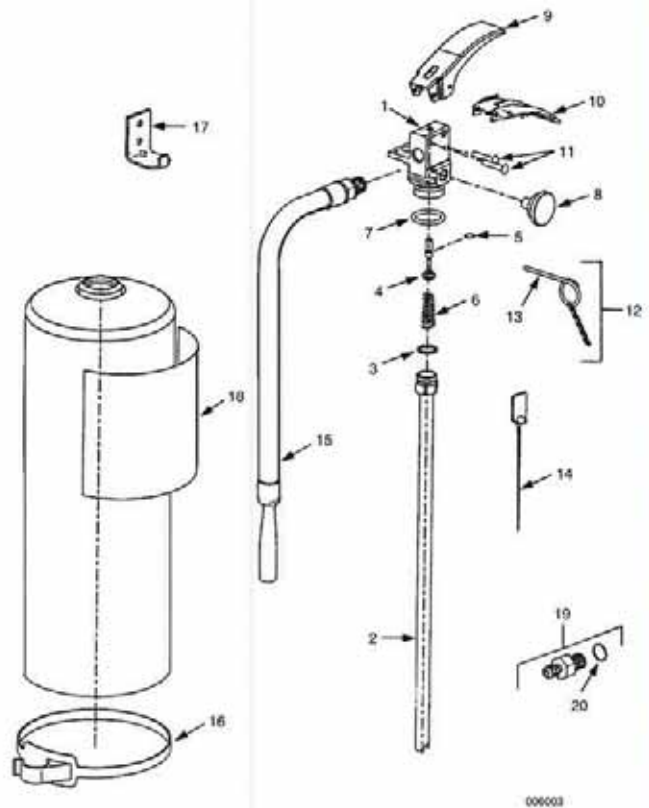

Fig. No.	Description	Part No.
19	Adaptor Assembly, Recharge	429642
19	Adaptor, Recharge Combination	440623
20	O-Ring	57744
—	Refill Agent, A10H, A10T	53080
—	Refill Agent, AA10S/AA20	415788
—	Refill Agent, AA20-1	434906
—	Refill Agent, PK10, PK10S, PK20	9335
—	Refill Agent, C10, C20	9336

SENTRY Industrial Corrosion-Resistant Dry Chemical Models A10I, AA10SI, PK10I, PK10SI, A20I, AA20I-1, PK20I

Fig. No.	Description	Part No.
—	Valve Assembly, 10S Models	436596
—	Valve Assembly, 10 lb Models	429088
—	Valve Assembly, 20 lb Models	429089
2	Tube, Pick-up, 10 lb Models	436843
2	Tube, Pick-up, 20 lb Models	436845
2	Tube, Pick-up, 10S Models	437091
3	O-Ring (Pick-up Tube)	76076
4	Valve Stem with O-Ring Assembly	428431
5	O-Ring	11873
6	Spring	415565
7	O-Ring	428327
8	Gauge, Pressure	56776
9	Lever, Operating, Stainless Steel	428428
10	Handle, Carrying, Stainless Steel	428429
11	Rivet, Stainless Steel	428430
12	Ring Pin and Chain	432947
13	Ring Pin, Large Loop, Stainless Steel	429290
14	Seal, Visual Inspection	25940
15	Hose & Nozzle Assembly, A10I/C10I	428733
15	Hose & Nozzle Assembly, AA10S-I	436593
15	Hose & Nozzle Assembly, PK10S-I	436794
15	Hose & Nozzle Assembly, PK10I	428735
15	Hose & Nozzle Assembly, A20I/AA20I-1	428737
15	Hose & Nozzle Assembly, PK20I	428739
16	Hose Retainer	427995
17	Hanger Hook, 10	428223
17	Hanger Hook, 10S	428222
17	Hanger Hook, 20	428224
18	Nameplate, Oper & Maint w/o UL	Call
19	Adaptor Assembly, Recharge	429642
19	Adaptor, Recharge Combination	440623
20	O-Ring	57744



STORED PRESSURE FIRE EXTINGUISHERS

SENTRY High Flow Dry Chemical

Fig. No.	Description	Part No.
–	Valve Assembly, CR-HF-10SI w/tube	441263
–	Valve Assembly, CR-HF-20I w/tube	441262
–	Valve Assembly, 20 lb Models, High Flow	440950
–	Valve Assembly, 10 lb Models, High Flow	440951
2	Tube, Pick-up, 10S	437091
2	Tube, Pick-up, 20 lb Models	436845
3	O-Ring (Pick-up Tube)	76076
4	Valve Stem Assembly	429099
4	Valve Stem with O-Ring, Corrosion-Resistant	428431
5	O-Ring	11873
6	Spring	415565
7	O-Ring	428327
8	Gauge, Pressure, 240 psi	440953
9	Lever, Operating	429096
9	Lever, Operating, Stainless Steel	428428
10	Handle, Carrying	429097
10	Handle, Carrying, Stainless Steel	428429
11	Rivet, Operating Lever	428130
11	Rivet, Operating Lever, Stainless Steel	428430
12	Rivet, Carrying Handle	428130
12	Rivet, Carrying Handle, Stainless Steel	428430
13	Ring Pin, Large Loop	434211
13	Ring Pin & Chain Assembly, Stainless Steel	432947
13	Ring Pin (Only), Stainless Steel	429290
14	Seal, Visual Inspection	25940
15	Hose & Nozzle Assy, HF-AA10S	440948
15	Hose & Nozzle Assembly, HF-PK10S	440938
15	Hose & Nozzle Assembly, HF-AA20-1	440943
15	Hose & Nozzle Assembly, HF-PK20	440933
15	Hose & Nozzle Assembly, CR-HF-PK20I	441237
15	Hose & Nozzle Assembly, CR-HF-PK10SI	441253
15	Hose & Nozzle Assembly, CR-HF-AA20I-1	441257
15	Hose & Nozzle Assembly, CR-HF-AA10SI	441261
16	Hose Retainer	427995
17	Hanger Hook (10S)	428222
17	Hanger Hook (AA20)	428224
18	Nameplate, Oper & Maint w/o UL/ULC	Call
19	Adaptor Assembly, Recharge	429642
19	Adaptor, Recharge Combination	440623
20	O-Ring	57744

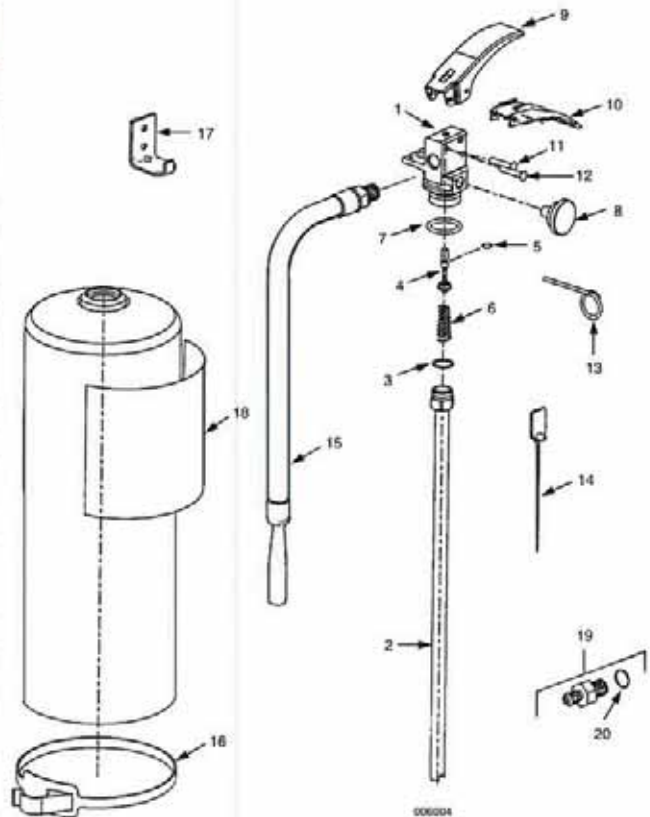

SENTRY Carbon Dioxide Models CD05A-1 (Aluminum), CD05-1 (Steel)

Fig. No.	Description	Part No.
-	Valve Assembly, CD05A-1	441002
-	Valve Assembly, CD05-1, Steel	441003
1	Valve Body, CD05-1	N/A
2	Lever, Black	441006
2	Lever, Stainless Steel	436468
3	Ring Pin	423624
4	Handle, Black	435291
4	Handle, Stainless Steel	436469
5	Safety Plug Assembly	429515
6	Handle Rivet	429165
7	Plunger Assembly	441004
8	Spring	415565
9	O-Ring, Valve to Cylinder	429170
10	Pick-Up Tube	79475
11	Nozzle	429185
12	Horn	429184
13	Nylon Washer	429183
14	Swivel Assembly	429173
15	Hanger Hook	79356
16	Adaptor, Pick-up Tube (not shown)	431001
-	Nameplate, Replacement w/o UL	Call

N/A = Not Available

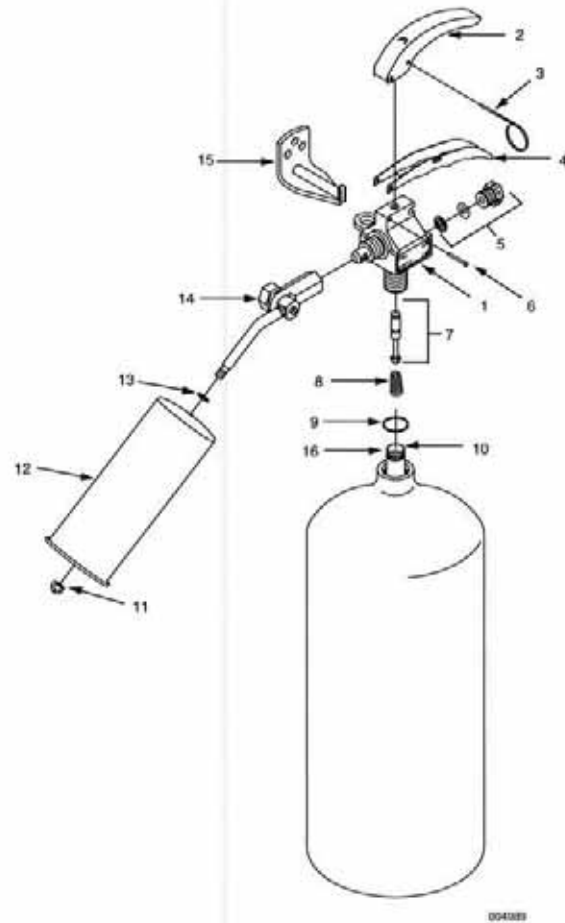

STORED PRESSURE FIRE EXTINGUISHERS

SENTRY Carbon Dioxide Models CD10A-1, CD15A-1, CD20A-1 (Aluminum); CD10-1, CD10-2, CD15-1, CD15-2, CD20-1, CD20-2 (Steel)

Fig. No.	Description	Part No.
-	Valve Assembly, Aluminum Models	441002
-	Valve Assembly, Steel Models	441003
1	Lever, Black	441006
1	Lever, Stainless Steel	436468
2	Ring Pin	423624
3	Handle, Black	435291
3	Handle, Stainless Steel	436469
4	Safety Plug w/Disc & Washer	434607
5	Rivet	429165
6	Plunger Assembly	441004
7	Spring	415565
8	Adaptor	431001
9	O-Ring, Valve to Cylinder, Aluminum Models Only	429170
10	Pick-up Tube, CD10A-1	431551
10	Pick-up Tube, CD10-1	431552
10	Pick-up Tube, CD15-1/CD20-1	79478
10	Pick-up Tube, CD10-2	442418
10	Pick-up Tube, CD15-2	442424
10	Pick-up Tube, CD20-2	442430
11	Horn/Hose Retainer, 10-15-20 lb Models, One-Piece	471789
12	Band, Metal, 10-15 Models	429348
12	Band, Metal, 20 Model	429349
13	Hex Nut (2 Required)	429202
14	Right Clamp	429199
15	Left Clamp	429200
16	Screw (2 Required)	429201
17	Nozzle, Orifice, 10 lb Models	429198
17	Nozzle, Orifice, 15 lb Models	429210
17	Nozzle, Orifice, 20 lb Models	431621
18	Horn	429197
19	Hose	429196
20	Hanger Hook, 10-15 lb Models	79357
20	Hanger Hook, 20 lb Models	79358
-	Nameplate, Replacement w/o UL	Call

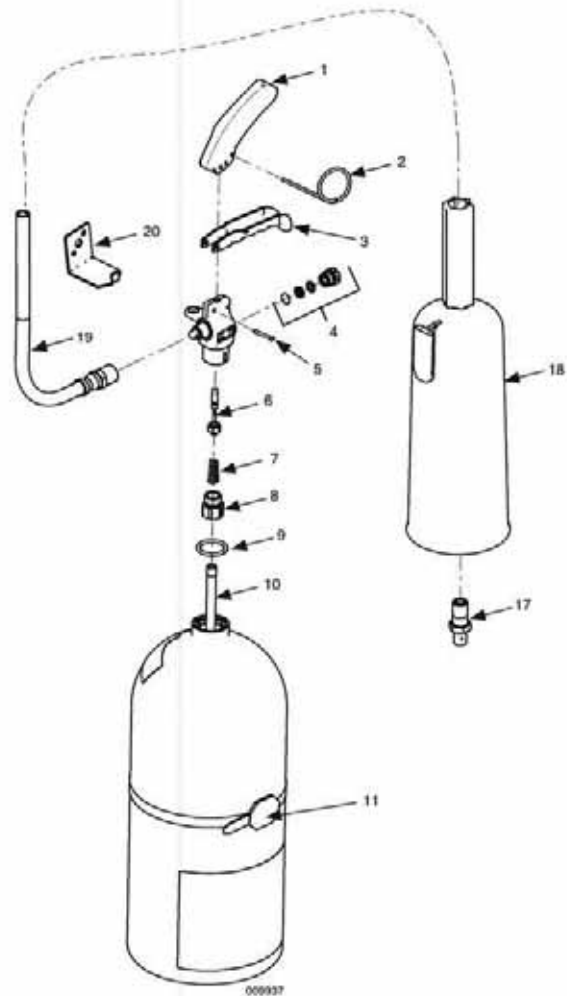

Alternative Metal Band

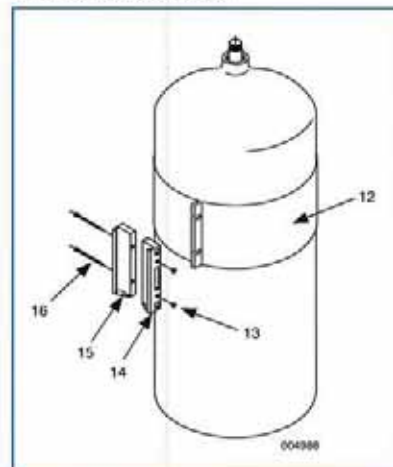

SENTRY Carbon Dioxide Models SY-0571 (Steel), SY-0572 (Aluminum)

Fig. No.	Description	Part No.
1	Valve Assembly, SY-0572	N/A
1	Valve Assembly, SY-0571	79354
2	Plunger Assembly	79806
3	Safety Plug Assembly	79786
4	Ring Pin	423624
5	Discharge Tube Assembly	73861
6	Discharge Horn	79350
7	Tube, Siphon	79475
8	O-Ring, Valve to Cylinder, SY-0572 Only	79805
9	Hanger Hook	79356
10	Visual Seal (Not Shown)	25940

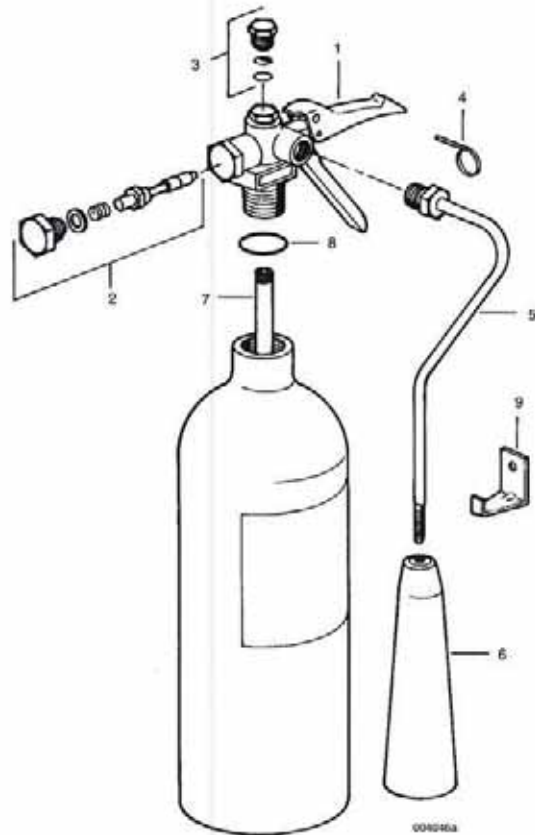

STORED PRESSURE FIRE EXTINGUISHERS

STORED PRESSURE FIRE EXTINGUISHERS

SENTRY Carbon Dioxide Models SY-1071, SY-1571, SY-2071 (Aluminum); Models SY-1072, SY-1572, SY-2072 (Steel)

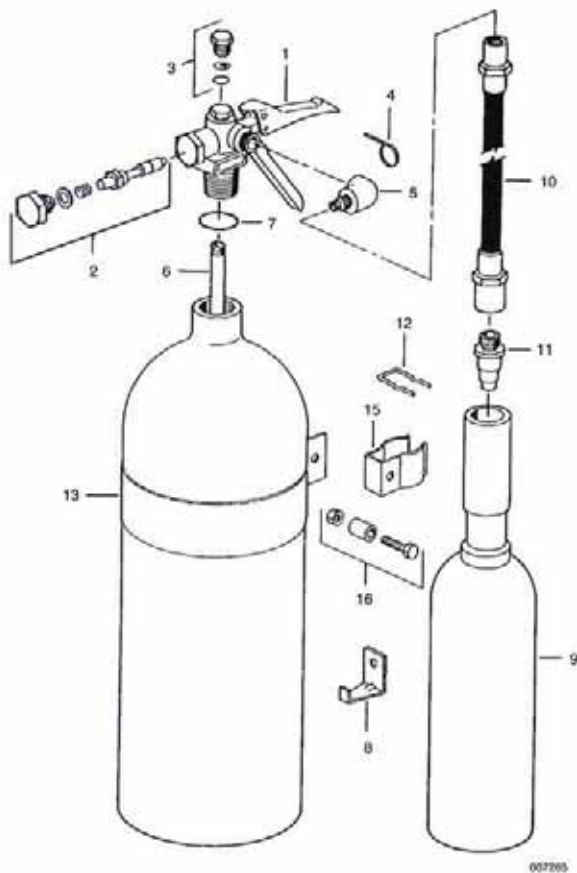
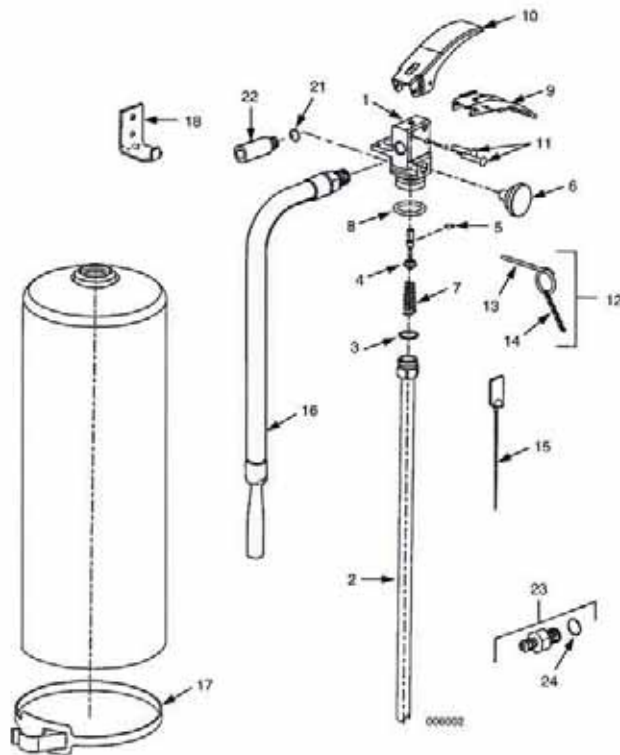

Fig. No.	Description	Part No.
1	Valve Assembly, Aluminum Models	N/A
1	Valve Assembly, Steel Models	N/A
2	Plunger Assembly	79806
3	Safety Plug w/Disc & Washer	79786
4	Ring Pin	423624
5	Elbow	79352
6	Tube, Siphon, SY-1072	N/A
6	Tube, Siphon, SY 1071	N/A
6	Tube, Siphon, 15-20 lb Models	79478
7	O-Ring, Valve to Cylinder, Aluminum Models Only	79805
8	Hanger Hook, 10-15 lb Models	79357
8	Hanger Hook, 20 lb Models	79358
9	Horn, 10-15 lb Models	77892
9	Horn, 20 lb Models	77893
10	Hose Assembly	77628
11	Nozzle Orifice, 10 lb Models	79473
11	Nozzle Orifice, 15-20 lb Models	79474
12	Clip, Horn	77894
13	Band, SY-1072/1572	N/A
13	Band, SY-2071 (As Supply Lasts)	79777
13	Band, SY-2072	N/A
14	Visual Seal (Not Shown)	25940
15	Nozzle Retainer	79783
16	Hardware Kit (Bolt, Nut, Spacer)	79471

CLEANGUARD Fire Extinguisher Parts



Model FE13NM*

Fig. No.	Description	Part No.
—	Valve Assembly	432896
1	Valve Body, Plated	428434
2	Tube, Pick-up	432897
3	O-Ring	76076
4	Valve Stem Assembly (includes O-Ring)	428431
5	O-Ring	11873
6	Gauge	428940
7	Spring, SS	430004
8	O-Ring	428327
9	Handle, SS	428429
10	Push Lever, SS	428428
11	Rivet (2), Brass	428430
12	Ring Pin/Chain Assembly	432947
13	Ring Pin, SS	429290
14	Chain	507
15	Seal, Visual Inspection	25940
16	Hose & Nozzle Assembly	432948
17	Hose Retainer	427995
18	Hanger Bracket, SS	432964
19	Nameplate, Replacement w/o UL/ULC Approval	Call

*NM - MR Conditional

Models FE02VB, FE05, FE05S, FE09, FE13

Fig. No.	Description	Part No.
—	Valve Assembly, FE02VB	429090
—	Valve Assembly, FE05	429091
—	Valve Assembly, FE05S	442366
—	Valve Assembly, FE09	429092
—	Valve Assembly, FE13	429093
1	Valve Body, Anodized	N/A
2	Tube, Pick-up, FE02VB	428795
2	Tube, Pick-up, FE05	428796
2	Tube, Pick-up, FE05S	442367
2	Tube, Pick-up, FE09	428797
2	Tube, Pick-up, FE13	428799
3	O-Ring	76076
4	Valve Stem Assembly (includes O-Ring)	429099
5	O-Ring	11873
6	Gauge, FE02VB, FE05, FE05S	426264
6	Gauge, FE09, FE13	428940
7	Spring	415565
8	O-Ring	428327
9	Handle, Finished	429097
10	Push Lever, Finished	429096
11	Rivet (2)	428130
12	Ring Pin/Chain Assembly	16234
13	Ring Pin	434211
14	Chain	507
15	Seal, Visual Inspection	25940
16	Hose & Nozzle Assembly, FE05	428742
16	Hose & Nozzle Assembly, FE05S	442353
16	Hose & Nozzle Assembly, FE09, FE13	428743
17	Hose Retainer, FE05, FE05S, FE09, FE13	427995
18	Hanger Bracket, FE02	21873
18	Hanger Bracket, FE05, FE05S	54405
18	Hanger Bracket, FE09, FE13	428224
19	Replacement Nameplate, FE02VB	429685
19	Replacement Nameplate, FE05	429686
19	Replacement Nameplate, FE09	429687
19	Replacement Nameplate, FE13	429688
20	Vehicle Bracket (Not Shown)	24610
21	O-Ring	57744
22	Nozzle, FE02	429118
23	Adaptor Assembly, Recharge	429642
24	O-Ring	57744
—	Recharge Tank, 50 lb	422817

STORED PRESSURE FIRE EXTINGUISHERS

CLEANGUARD Fire Extinguisher Parts

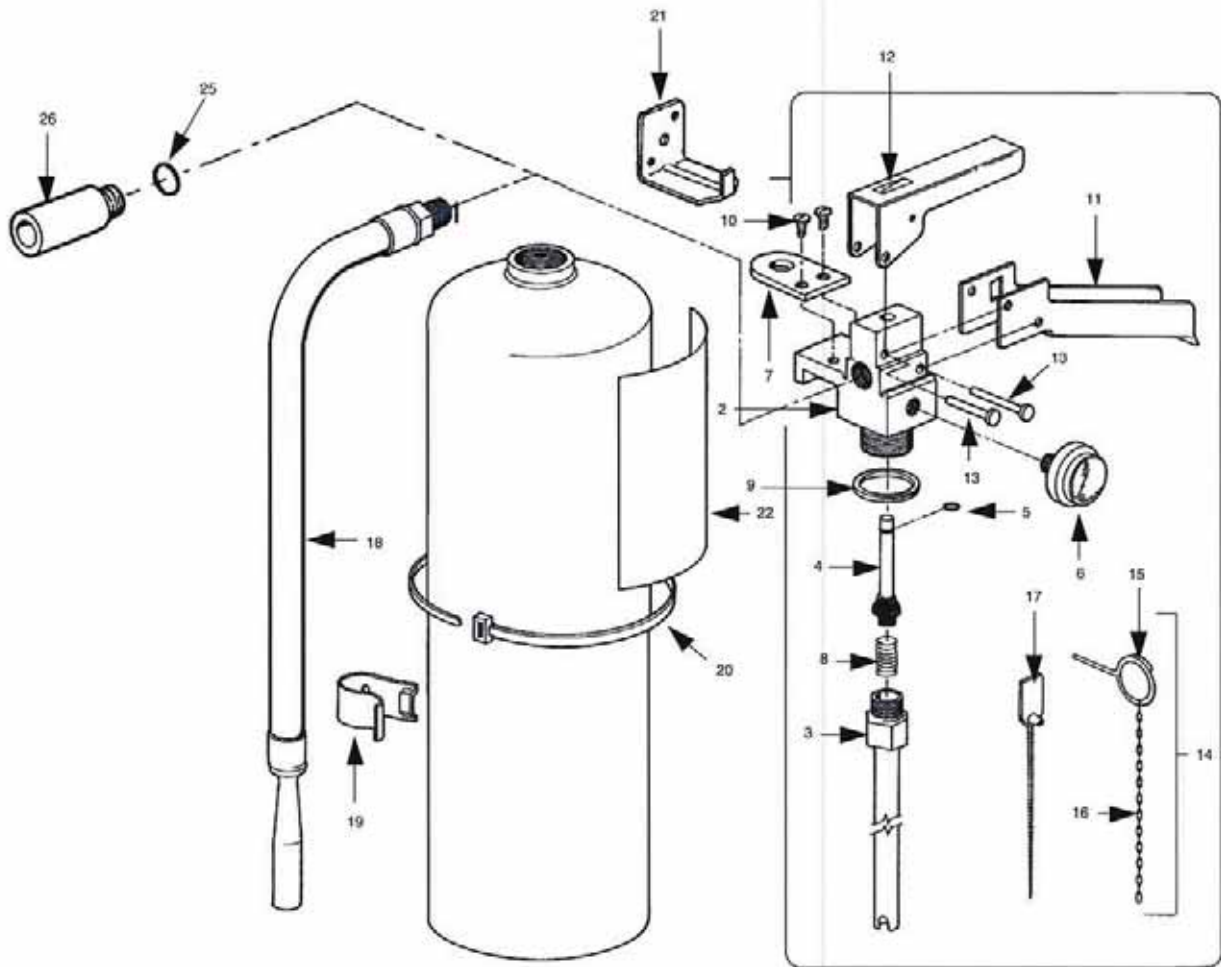

000760

CLEANGUARD Fire Extinguisher Parts

Models CA-0681, CA-0981, CA-1081, CA-1381, CA-1481

Fig. No.	Description	Part No.
1	Valve Assembly, CA-0681, 0981, 1081	N/A
1	Valve Assembly, CA-1381, 1481	N/A
2	Valve Body, Anodized	N/A
3	Tube, Pick-up	N/A
4	Valve Stem Assembly	24489
5	O-Ring	11873
6	Gauge	N/A
7	Conversion Hanger	21864
8	Spring	29256
9	Quad Ring	21882
10	Screw, Self-Tapping (2)	28589
11	Handle, Finished	N/A
12	Push Lever, Finished	N/A
13	Rivet (2)	N/A
14	Ring Pin/Chain Assembly	N/A
15	Ring Pin	434211
16	Chain	507
17	Seal, Visual Inspection	25940
18	Hose and Nozzle Assembly, CA-0681	N/A
18	Hose and Nozzle Assembly, CA-0981	N/A
18	Hose and Nozzle Assembly, CA-1081	N/A
18	Hose and Nozzle Assembly, CA-1381, 1481 ULC	N/A
18	Hose and Nozzle Assembly, CA-1481 UL	N/A
19	Hose Clip	N/A
20	Locking Cable	N/A
21	Hanger Bracket, CA-0681	79357
21	Hanger Bracket, Except CA-0681	79356
23	Inspection Record Tag (Not Shown), CA-1081 ULC	31447
23	Inspection Record Tag (Not Shown), Except CA-1081 ULI	2364
24	Vehicle Bracket (Not Shown), CA-0681	30865
24	Veh. Bracket (Not Shown), CA-0981, 1081	422737
24	Veh. Bracket (Not Shown), CA-1381, 1481	30937
—	Replacement Hose Retainer	427995

Models CA-0281, CA-0581, CA-0582

Fig. No.	Description	Part No.
1	Valve Assembly, CA-0281	N/A
1	Valve Assembly, CA-0581	N/A
1	Valve Assembly, CA-0582	N/A
2	Valve Body, Anodized, CA-0281, 0582	N/A
2	Valve Body, Anodized, CA-0581	N/A
3	Tube, Pick-up, CA-0281	N/A
3	Tube, Pick-up, CA-0581	N/A
3	Tube, Pick-up, CA-0582	N/A
4	Valve Stem Assembly, CA-0281, 0582	N/A
4	Valve Stem Assembly, CA-0581	N/A
5	O-Ring	11873
6	Gauge, CA-0281, 0582	426264
6	Gauge, CA-0581	428940
7	Conversion Hanger, CA-0581	21864
8	Spring, CA-0281, 0582	415565
8	Spring, CA-0581	29256
9	Quad Ring, CA-0281, 0582	79122
9	Quad Ring, CA-0581	21882
10	Screw, Self-Tapping (2)	28589
11	Handle, Finished, CA-0281, 0582	N/A
11	Handle, Finished, CA-0581	N/A
12	Push Lever, Finished, CA-0281, 0582	N/A
12	Push Lever, Finished, CA-0581	N/A
13	Rivet (2) , CA-0281, 0582	N/A
13	Rivet (2) , CA-0581	N/A
14	Ring Pin/Chain Assembly, CA-0581	16234
15	Ring Pin, CA-0581	434211
16	Chain, CA-0581	507
17	Seal, Visual Inspection	25940
18	Hose and Nozzle Assembly, CA-0581	N/A
18	Hose and Nozzle Assembly, CA-0582	N/A
19	Hose Clip, CA-0581, 0582	N/A
20	Locking Cable, CA-0581, 0582	N/A
21	Hanger Bracket, CA-0281	21873
21	Hanger Bracket, CA-0581	79356
21	Hanger Bracket, CA-0582	54405
23	Inspection Record Tag (Not Shown) Except CA-0581 ULI	2364
23	Inspection Record Tag (Not Shown), CA-0581 ULC	31447
24	Vehicle Bracket (Not Shown), CA-0281	24610
24	Vehicle Bracket (Not Shown), CA-0581	30865
24	Vehicle Bracket (Not Shown), CA-0582	415824
25	O-Ring, CA-0281	16047
26	Nozzle, CA-0281	N/A
—	Recharge Adaptor	429642

K-GUARD Models K01-1, K01-2, K01-3

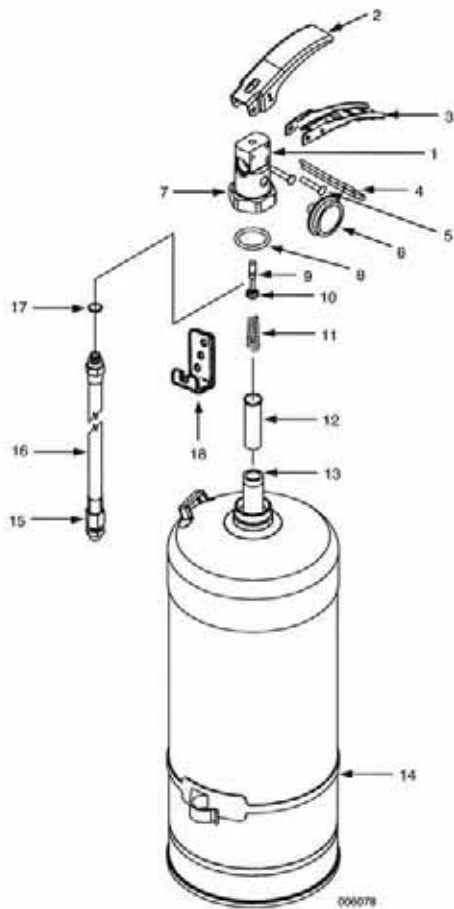

Fig. No.	Description	Part No.
1	Valve Body Assembly	430270
2	Lever	430924
3	Handle	430273
4	Ring Pin	430115
5	Rivet	430250
6	Gauge, 100 psi	429536
7	Collar Nut	430274
8	Collar O-Ring	56909
9	Valve Stem O-Ring	429159
10	Valve Stem	429099
11	Spring	430004
12	Fill Tube	429541
13	Pick-Up Tube Assembly	439713
14	Hose Retainer	427995
15	Nozzle Tip	439382
16	Hose and Nozzle Assembly	439495
17	Hose O-Ring	429544
18	Wall Hanger	430056
—	Heavy Duty Bracket (Not Shown)	422737
—	Visual Inspection Seal (Not Shown)	25940
—	Warning Placard, English/Spanish (Not Shown)	426021
—	Warning Placard, English/Can. French (Not Shown)	426034

SENTRY Water Extinguisher Model W02-1 (Water)

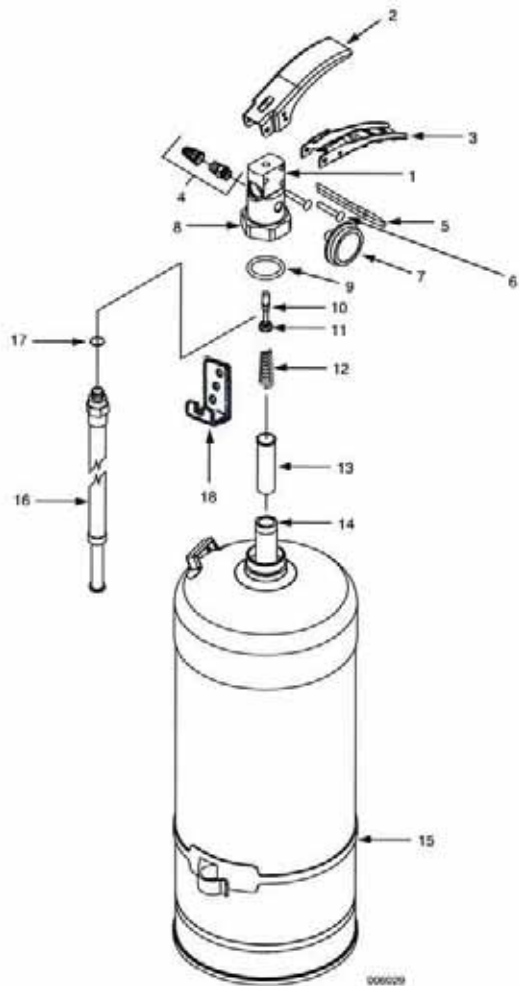
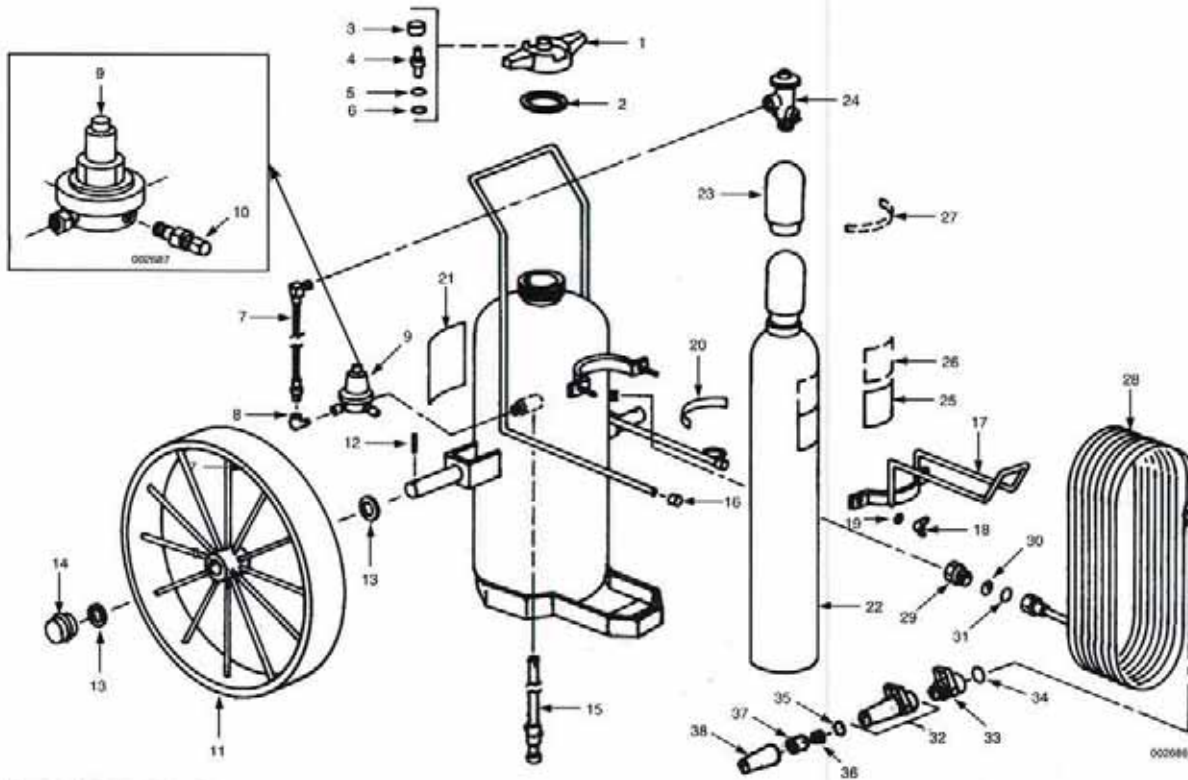

Fig. No.	Description	Part No.
1	Valve Body Assembly	430792
2	Lever	430924
3	Handle	430273
4	Schrader Valve, 0-200 psi	429542
5	Ring Pin	430115
6	Rivet	430250
7	Gauge, 100 psi	429536
8	Collar Nut	430274
9	Collar O-Ring	56909
10	Valve Stem O-Ring	429159
11	Valve Stem	429099
12	Spring	430004
13	Fill Tube	429541
14	Pick-Up Tube Assembly	437261
15	Hose Retainer	427995
16	Hose and Nozzle Assembly	429543
17	Hose O-Ring	429544
18	Wall Hanger	430056
-	Heavy Duty Bracket (Not Shown)	30937
-	Visual Inspection Seal (Not Shown)	25940

STORED PRESSURE FIRE EXTINGUISHERS

Models CR-150-C and CR-350-C



Model CR-150-C

Fig. No.	Description	Part No.
1	Fill Cap, Indicator	27335
2	Gasket	3461
3	Indicator Cap	17633
4	Indicator Stem	27648
5	Quad Ring	17630
6	Retaining Ring	71675
7	Nitrogen Hose Assembly	423585
8	Street Elbow	78409
9	Pressure Regulator Replacement	416938*
10	Pressure Relief Valve	78704
11	Wheel, Steel, Standard	29508
11	Wheel, Wide, WW	31015
11	Wheel, Rubber Coated	31012
12	Spring Pin	8560
13	Washer	67684
14	Hub Cap	56739
15	Gas Tube (Without Coupling)	78713
16	Cap	4120
17	Clamp/Hose Hanger	78328
18	Wing Nut	78315
19	Washer	1870
20	Rubber Pad	29414
21	Nameplate, Replacement w/o UL, FORAY	74338
21	Nameplate, Replacement w/o UL, PLUS-FIFTY C/Purple-K	16444
22	Nitrogen Cylinder Assembly	24707

Fig. No.	Description	Part No.
22	Nitrogen Cylinder Assembly, w/Valve	31060
23	Shipping Cap, Nitrogen Cylinder	73066
24	Valve, Nitrogen Cylinder	Pg. 64
25	Label, Nitrogen Cylinder	3477
26	Label, Nitrogen Cylinder, QO Valve	10994
27	Label, Cylinder Cap, QO Valve	11391
28	Hose, 3/4 in. x 50 ft (15 m), Standard	960
28	Hose, 3/4 in. x 100 ft (30 m), Standard	4761
28	Hose, 3/4 in. x 50 ft (15 m), LT	2272
28	Hose, 3/4 in. x 100 ft (30 m), LT	26299
29	Adaptor, FORAY, PLUS-FIFTY C, Purple-K, LR	24931
30	Visual Hose Inspection Disc	14236
31	Gasket	670
32	Nozzle Assembly, FORAY, PLUS-FIFTY C	29506
32	Nozzle Assembly, Purple-K	31449
32	Nozzle Assembly, LR	31013
33	Ball Valve, Nozzle	8101
34	Gasket, Valve to Hose	670
35	Gasket, Nozzle, Standard	8105
35	Gasket, Nozzle, LR	12734
36	Tip, Nozzle	12703
37	Sleeve, Nozzle	8103
38	Body, Nozzle, Except LR & Purple-K	29507
38	Body, Nozzle, LR	31014
38	Body, Nozzle, Purple-K	31448

Model CR-350-C

Fig. No.	Description	Part No.
1	Fill Cap, Indicator	27335
2	Gasket	3461
3	Indicator Cap	17633
4	Indicator Stem	27648
5	Quad Ring	17630
6	Retaining Ring	71675
7	Nitrogen Hose Assembly	423585
8	Street Elbow	78409
9	Pressure Regulator Replacement	416938*
10	Pressure Relief Valve	78704
11	Wheel, Steel, Standard	25908
11	Wheel, Rubber Coated	31016
12	Spring Pin	8560
13	Washer	67684
14	Hub Cap	56739
15	Gas Tube (Without Coupling)	77912
16	Cap	4120
17	Clamp/Hose Hanger	78362
18	Wing Nut	78315
19	Washer	1870
20	Rubber Pad	79183
21	Nameplate, Replacement w/o UL, FORAY	74338
21	Nameplate, Replacement w/o UL, PLUS-FIFTY C/Purple-K	16444
22	Nitrogen Cylinder Assembly	24708
22	Nitrogen Cylinder Assembly, QO Valve	31061

*Regulator Replacement

See Manual Part No. 53141 – “Pressure Regulator Testing for Wheeled and Stationary Extinguishers”

Fig. No.	Description	Part No.
23	Shipping Cap, Nitrogen Cylinder	73066
24	Valve, Nitrogen Cylinder	Pg. 64
25	Label, Nitrogen Cylinder	3391
26	Label, Nitrogen Cylinder, QO Valve	10994
27	Label, Cylinder Cap, QO Valve	11391
28	Hose, 1 in. x 50 ft (15 m), Standard	2271
28	Hose, 1 in. x 100 ft (30 m), Standard	10930
28	Hose, 1 in. x 50 ft (15 m), LT	2133
28	Hose, 1 in. x 100 ft (30 m), LT	10931
29	Adaptor, FORAY, PLUS-FIFTY C, Purple-K, LR	78316
29	Adaptor, Purple-K, Except LR	24930
30	Visual Hose Inspection Disc	14237
31	Gasket, Valve to Hose	445861
32	Nozzle Assembly, FORAY, PLUS-FIFTY C	31922
32	Nozzle Assembly, Purple-K	31547
32	Nozzle Assembly, LR	25906
33	Ball Valve, Nozzle	12727
34	Gasket, Valve to Hose	445861
35	Gasket, Nozzle, Standard	8105
35	Gasket, Nozzle, LR	12734
36	Tip, Nozzle	12707
37	Sleeve, Nozzle	8103
38	Body, Nozzle, Except LR	29507
38	Body, Nozzle, LR	25907
38	Body, Nozzle, Purple-K	31548

Model CR-150-D

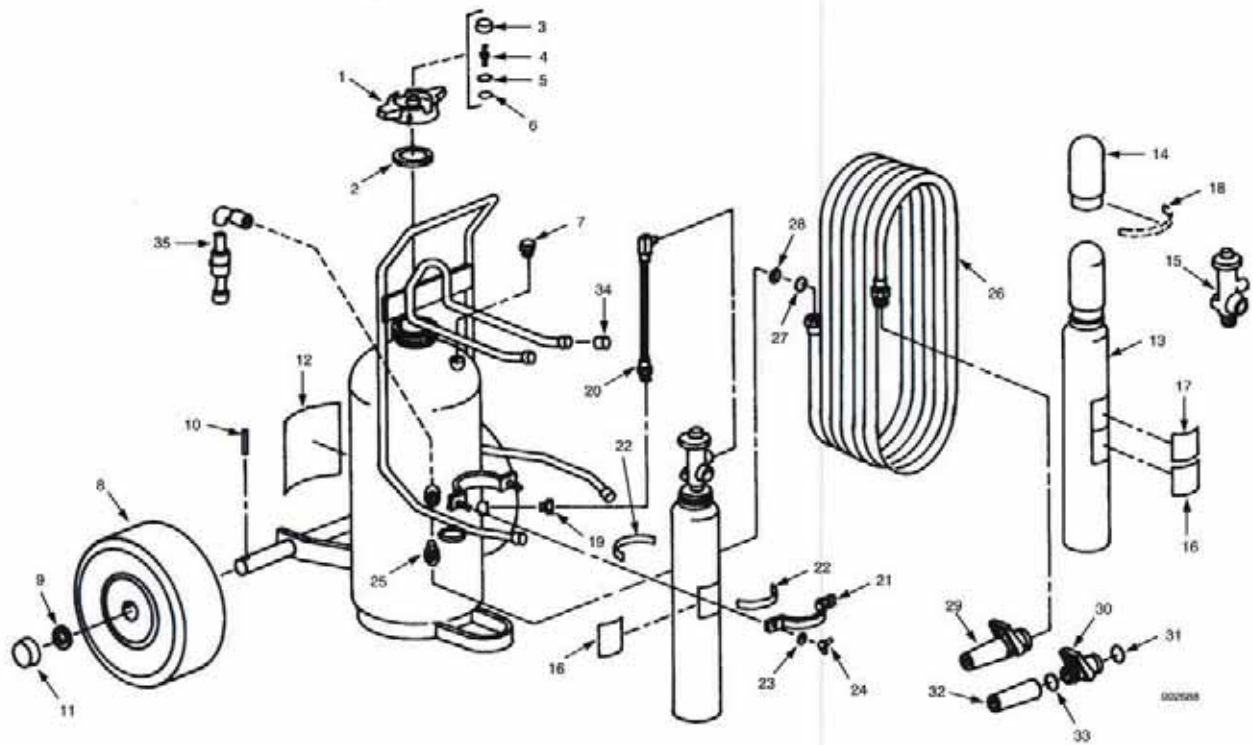

Fig. No.	Description	Part No.
1	Fill Cap, Indicator, w/Gasket	27335
2	Gasket, Fill Cap	3461
3	Housing, Indicator	17633
4	Stem, Indicator	27648
5	Quad Ring	17630
6	Retaining Ring	71675
7	Valve, Safety Relief	78380
8	Wheel Assembly, Semi-Pneumatic	53870
9	Washer	53541
10	Pin, Cotter	19620
11	Cap, Hub	53867
12	Nameplate, Replacement w/o UL, FORAY	74338
12	Nameplate, Replacement w/o UL, PLUS-FIFTY C/Purple-K	16444
13	Cylinder, Nitrogen 23 cu ft, Std Valve	54694
13	Cylinder, Nitrogen 23 cu ft, Quick-Opening Valve	54695
14	Cap, Safety Shipping	73066
15	Valve Assembly, Nitrogen Cylinder	Pg. 64
16	Label, Nitrogen Cylinder, Std	53182
17	Label, Nitrogen Cylinder, QO Valve	10994
18	Label, Nitrogen Cylinder Cap, QO Valve	11391
-	Plug, Safety, QO Valve (Not Shown)	11453

Fig. No.	Description	Part No.
19	Bushing 3/8 in. x 1/4 in.	19120
20	Hose and Adaptor Assembly	423581
21	Clamp Assembly	24877
22	Rubber Pad	29748
23	Washer	1870
24	Wingnut	78315
25	Adaptor, Tank Outlet to Hose	24931
26	Hose Assembly, 3/4 in. x 50 ft (15 m)	960
27	Gasket, Hose Coupling	670
28	Disc, Visual Hose Inspection	14236
29	Nozzle Assembly, Standard	31449
29	Nozzle Assembly, LR	31013
30	Ball Valve, Nozzle	8101
31	Gasket, Valve to Hose	670
32	Body, Nozzle, Standard	31448
32	Body, Nozzle, LR	31014
33	Gasket, Nozzle, Standard	8105
33	Gasket, Nozzle, LR	12734
34	Cap, Protective	4120
35	Gas Tube Assembly	24775
-	Tag, Inspection (Not Shown)	2364

Model CR-350-D

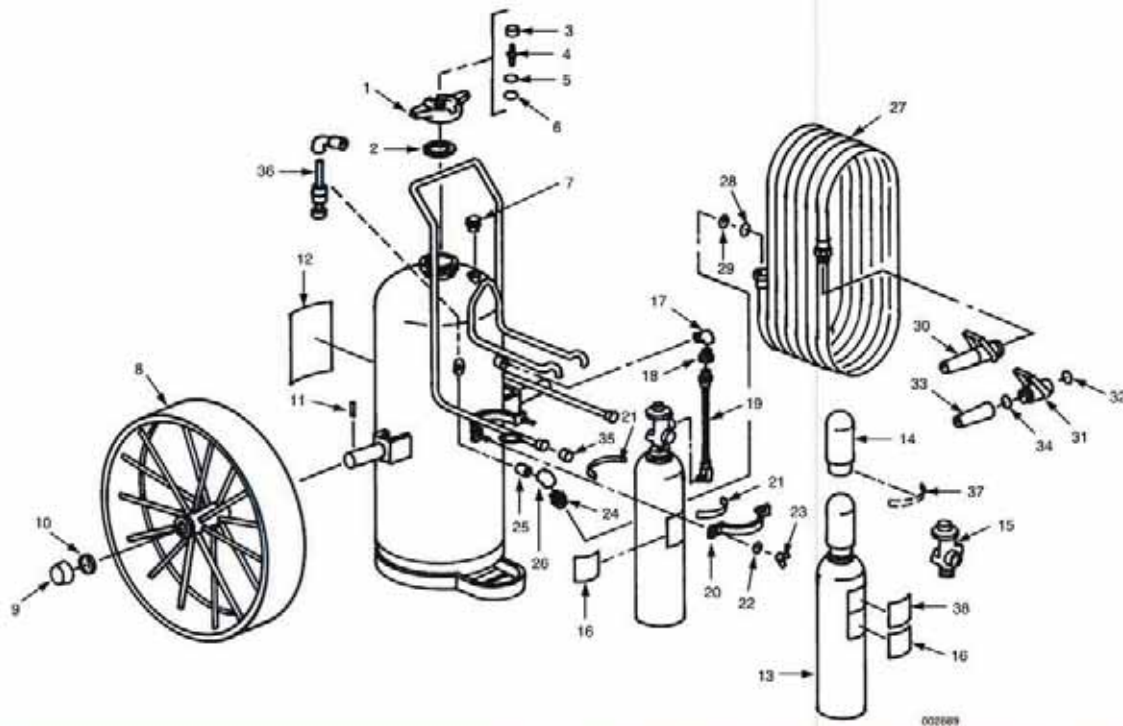

Fig. No.	Description	Part No.
1	Fill Cap, Indicator, w/Gasket	27335
2	Gasket, Fill Cap	3461
3	Housing, Indicator	17633
4	Stem, Indicator	27648
5	Quad Ring	17630
6	Retaining Ring	71675
7	Valve, Safety Relief	78380
8	Wheel Assembly (Steel - 6 in. Width)	31015
9	Hub Cap	58739
10	Washer (4)	67684
11	Pin, Spring (2)	8560
12	Nameplate, Replacement w/o UL, FORAY	70366
12	Nameplate, Replacement w/o UL, PLUS-FIFTY C	70367
12	Nameplate, Replacement w/o UL, Purple-K	70365
12	Nameplate, Replacement w/o UL, LR-350-D, FORAY	70383
12	Nameplate, Replacement w/o UL, LR-350-D, PLUS-FIFTY C/Purple-K	70371
13	Cylinder, Nitrogen, 55 cu ft, Std Valve	54696
13	Cylinder, Nitrogen, 55 cu ft, QO Valve	54697
14	Cap, Safety Shipping	73066
15	Valve Assembly, Nitrogen Cylinder	Pg. 64
16	Label, Nitrogen Cylinder, Std Valve	53181
-	Plug, Safety, QO Valve (Not Shown)	11453
17	Elbow, Street	53537
18	Bushing 3/8 in. x 1/4 in.	8390

Fig. No.	Description	Part No.
19	Hose and Adaptor Assembly	423581
20	Clamp Assembly	16359
21	Rubber Pad	29414
22	Washer	1870
23	Wingnut	78315
24	Adaptor	24930
25	Nipple, 3/4 in. Extra Heavy	1978
26	Elbow, 3/4 in. 45°	1967
27	Hose Assembly 1 in. x 50 ft	2271
28	Gasket, Hose Coupling	8105
29	Disc, Visual Inspection	14237
30	Nozzle Assembly, Standard, PLUS-FIFTY C, FORAY	53881
30	Nozzle Assembly, Standard, Purple-K	53888
30	Nozzle Assembly, LR	25906
31	Ball Valve, Nozzle	12727
32	Gasket, Valve to Hose	445861
33	Body, Nozzle Assembly, PLUS-FIFTY C, FORAY	53882
33	Body, Nozzle Assembly, Purple-K	53889
33	Body, Nozzle Assembly, LR	25907
34	Gasket, Nozzle, Standard	8105
34	Gasket, Nozzle, LR	12734
35	Cap, Protective	4120
36	Gas Tube Assembly	53535
37	Label, Nitrogen Cylinder Cap, QO Valve	11391
38	Label, Nitrogen Cylinder, QO Valve	10994
-	Tag, Inspection (Not Shown)	2364

Model CD-50-D and CD-50-D-1

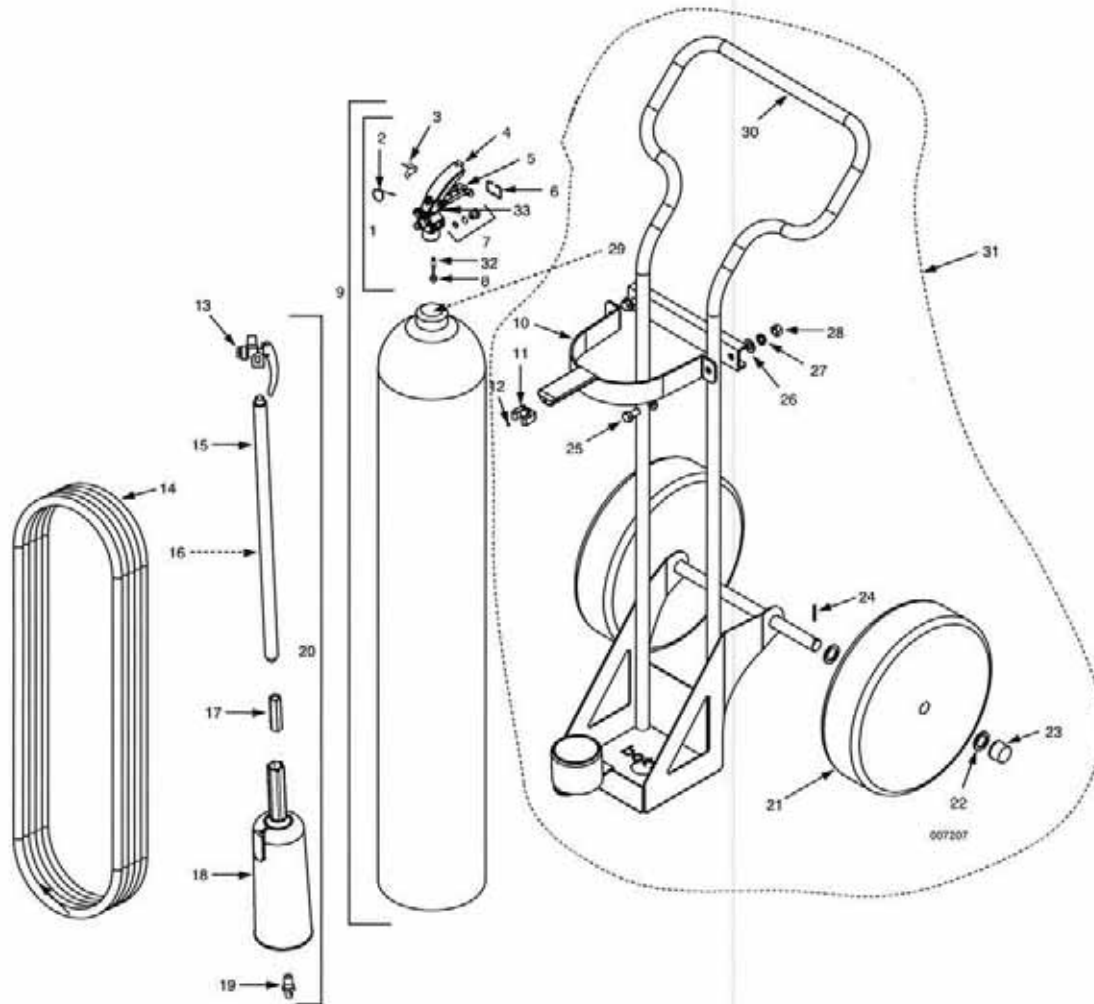

Fig. No.	Description	Part No.
1	Cylinder Valve Assembly (no pick-up tube)	441008
2	Pull Pin	423624
3	Leaf Spring	429162
4	Lever, Chrome, Plated Brass	441012
5	Handle, Chrome, Plated Brass	441013
6	Lever Catch	429244
7	Burst Disc	434607
8	Plunger Stem	441009
9	50 lb (22.7 kg) CO ₂ Shipping Assembly	552314
10	Bracket - Painted	552331
11	Hose Clip	552309
12	Rivet - Stainless Steel	552307
13	CO ₂ Discharge Valve	552719
14	Hose Assembly, 15 ft (4.6 m)	552334
15	Rubber Tubing	552721
16	Discharge Pipe	552720
17	Horn Adaptor	552724
18	Discharge Horn	429197

Fig. No.	Description	Part No.
19	Discharge Nozzle	552723
20	Discharge Valve/Horn Assembly	429249
21	16 in. (40.6 cm) Wheel	53870
22	Washer	53541
23	Hub Cap	53867
24	Roll Pin	69855
25	1/2 - 13 Hex Head Bolt	16117
26	1/2 Flat Washer	17486
27	1/2 Lockwasher	16121
28	1/2 - 13 Hex Nut	16119
29	Pickup Tube (inside shell 48.5 in.)	552336
30	50 lb (22.7 kg) CO ₂ Cart Only	552332
31	50 lb (22.7 kg) CO ₂ Cart Assembly (excluding CO ₂ Cylinder)	553326
32	O-Ring, Valve Stem	429159
33	Rivet, Handle	429165
-	Safety Plug Kit	429515
-	Replacement Nameplates w/o UL, CD-50-D-1	440646

Model CD-100-D and CD-100-D-1

WHEELED FIRE EXTINGUISHERS

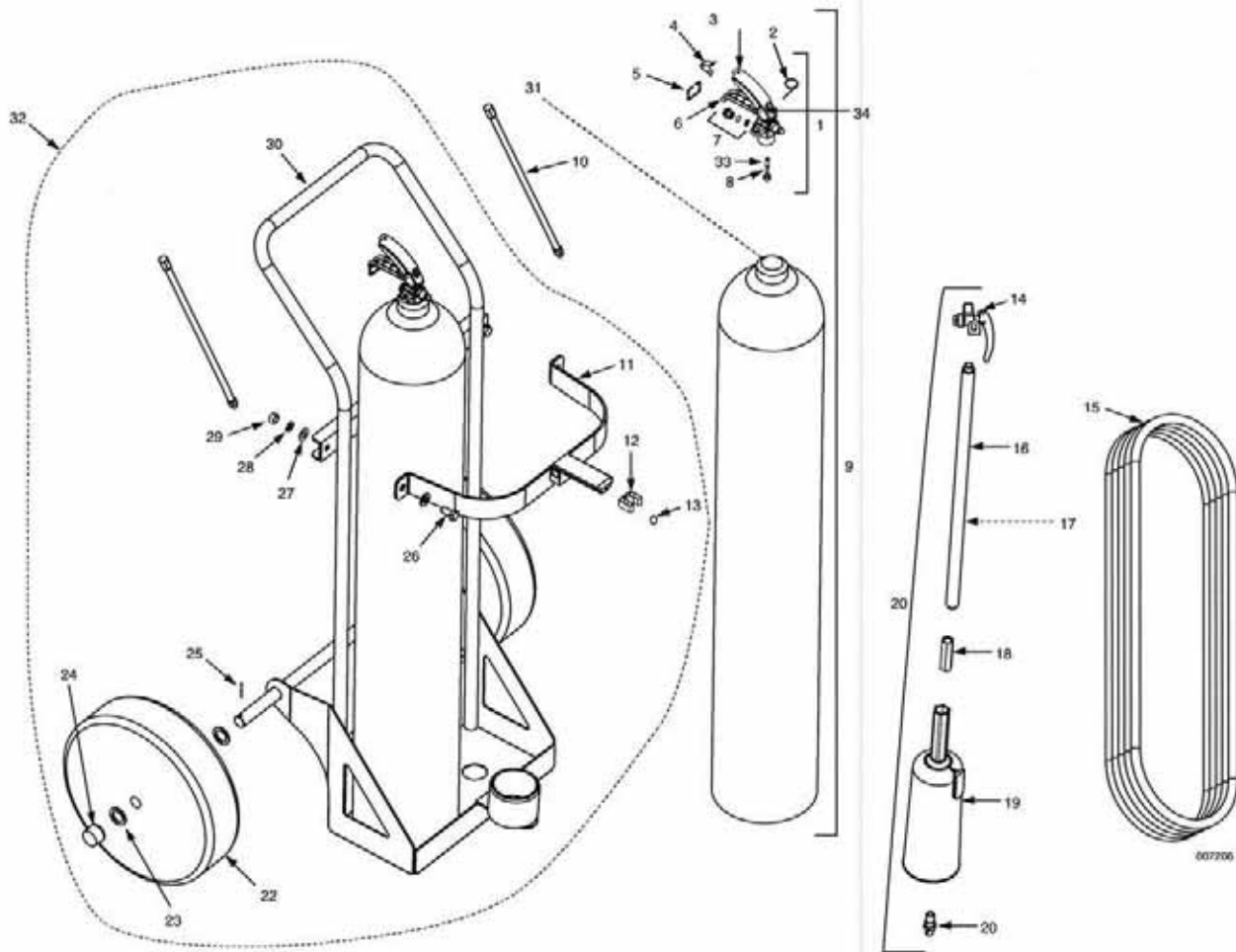
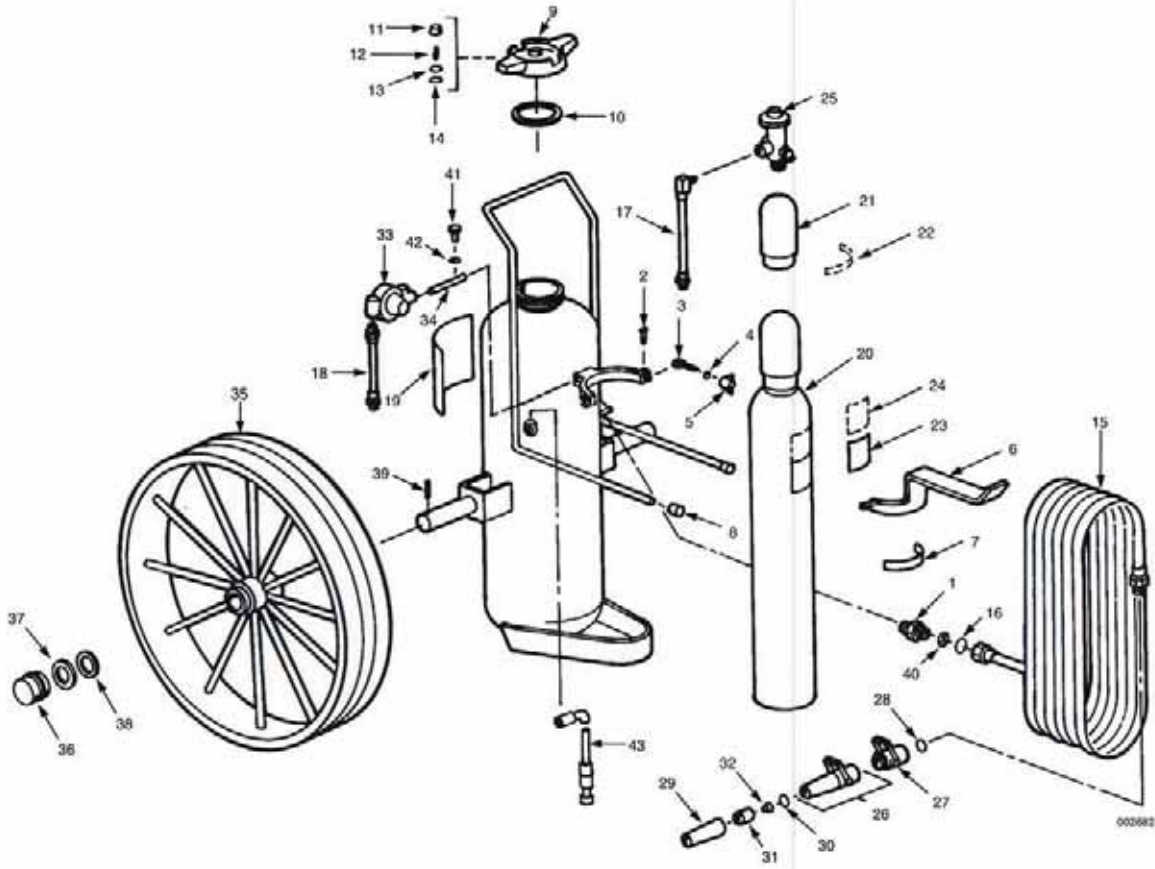

Fig. No.	Description	Part No.
1	Cylinder Valve Assembly (no pick-up tube)	441008
2	Pull Pin	423624
3	Lever, Chrome, Plated Brass	441012
4	Leaf Spring	429162
5	Lever Catch	429244
6	Handle, Chrome, Plated Brass	441013
7	Safety Plug Kit	434607
8	Plunger Stem	441009
9	50 lb (22.7 kg) CO ₂ Shipping Assembly	552314
10	20 in. (50.8 cm) Hose Assembly	552356
11	Bracket – Painted	552311
12	Hose Clip	552309
13	Rivet – Stainless Steel	552307
14	CO ₂ Discharge Valve	552719
15	Hose Assembly, 40 ft (12.2 m) CD-100-D-1	552302
15	Hose Assembly, 40 ft (12.2 m) CD-100-D	429273
16	Rubber Tubing	552721
17	Discharge Pipe	552720

Fig. No.	Description	Part No.
18	Horn Adaptor	552724
19	Discharge Horn	429197
20	Discharge Nozzle	552723
21	Discharge Valve/Horn Assembly	429249
22	16 in. (40.6 cm) Wheel	53870
23	Washer	53541
24	Hub Cap	53867
25	Roll Pin	69855
26	1/2 – 13 Hex Head Bolt	16117
27	1/2 Flat Washer	17486
28	1/2 Lockwasher	16121
29	1/2 – 13 Hex Nut	16119
30	100 lb (45.4 kg) CO ₂ Cart Only	552313
31	Pickup Tube (inside shell 48.5 in.)	552336
32	100 lb (45.4 kg) CO ₂ Cart Assembly (excluding CO ₂ Cylinder)	553327
33	O-Ring, Valve Stem	429159
34	Rivet, Handle	429165
–	Safety Plug Kit	429515
–	Replacement Nameplates w/o UL, CD-100-D-1	440647

WHEELED FIRE EXTINGUISHERS

Model CR-150-C (Pre-1989)



Model CR-150-C (Pre-1989)

Fig. No.	Description	Part No.
1	Adaptor, Tank Outlet to Hose	3902
2	Rivet, Eyebolt	15392
3	Eyebolt, Clamp Ring	N/A
4	Washer	1870
5	Wing Nut, Eyebolt	78315
6	Clamp Ring 'B' w/Hose Support	N/A
7	Rubber Pad	29414
8	Confiner Tip	4120
9	Fill Cap, Indicator, w/Gasket	27335
10	Gasket, Fill Cap	3461
11	Housing, Indicator	17633
12	Stern, Indicator	27648
13	Quad Ring	17630
14	Retaining Ring	71675
15	Hose Assembly, 3/4 in. x 50 ft	960
16	Gasket, Hose Coupling	670
17	Hose and Adaptor Assembly, 3/8 in.	423581
18	Hose Assembly, 3/8 in., Regulator to Tank	8750
19	Nameplate, Replacement w/o UL	70157
20	Nitrogen Cylinder Assembly, 110	24707
20	Nitrogen Cylinder Assembly, 110, QO Valve	31060
21	Cap, Nitrogen Cylinder	73066
22	Label, Nitrogen Cylinder Cap, QO Valve	11391
23	Label, Nitrogen Cylinder, Standard	3477
24	Label, Nitrogen Cylinder, QO Valve	10994
25	Valve Assembly, Nitrogen Cylinder, Standard & QO	Pg. 64
26	Nozzle Assembly, Standard Cone Tip, Pre-1976	29506

Fig. No.	Description	Part No.
26	Nozzle Assembly, Purple-K Only, Pre-1976	31449
26	Nozzle Assembly, LR-36	31013
27	Valve, Nozzle Assembly	8101
28	Gasket, Valve to Hose	445861
29	Body, Nozzle, Standard Cone Tip, Pre-1976	29507
29	Body, Nozzle, Purple-K Only, 1976-1988	31448
29	Body, Nozzle Assembly, LR-36	31014
30	Gasket, Nozzle Assembly	670
30	Gasket, Nozzle Assembly, LR-36	12734
31	Sleeve, Nozzle Assembly, Standard Cone Tip, Pre-1976	8103
32	Tip, Nozzle Assembly, Standard Cone Tip, Pre-1976	12703
33	Regulator Replacement	416938*
34	Support, Regulator	74265
35	Wheel Assembly, 3 in. Wide, Steel, Red	29508
36	Hub Cap	56739
37	Washer (3.3 mm)	67684
38	Washer (1.5 mm)	N/A
39	Pin, Spring	8560
40	Visual Hose Inspection Disc	14236
41	Cap Screw, Regulator Mounting	16301
42	Lockwasher, Regulator Mounting	1133
43	Gas Tube Assembly	15469
—	Strap, Regulator Mounting (Not Shown)	N/A
—	Lockwasher, Regulator Mounting (2) (Not Shown)	14235
—	Hex Nut, Regulator Mounting (2) (Not Shown)	14234

N/A = Not Available

*Regulator Replacement

See Manual Part No. 53141 – "Pressure Regulator Testing for Wheeled and Stationary Extinguishers"

WHEELED FIRE EXTINGUISHERS

Model CR-350-C (Pre-1989)

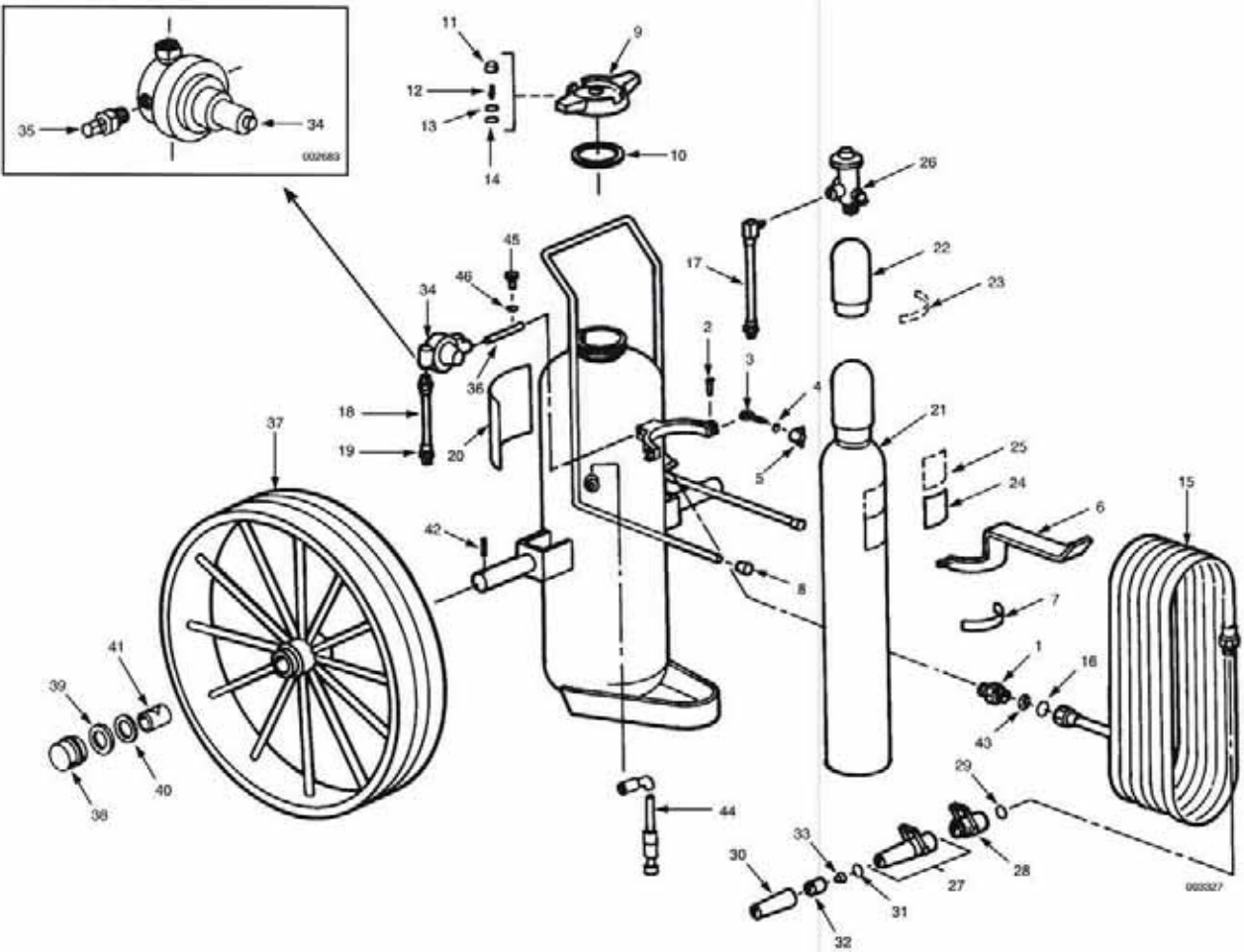
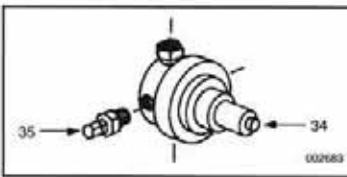
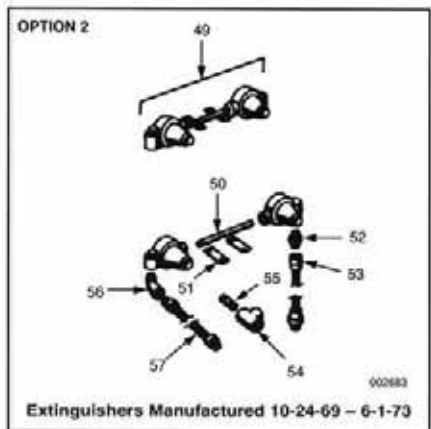
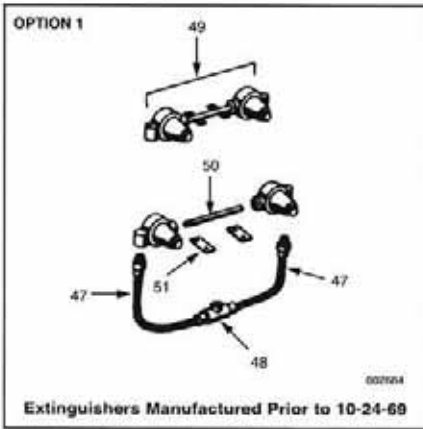

Model CR-350-C (Pre-1989)

Fig. No.	Description	Part No.
1	Adaptor, Tank Outlet to Hose	7837
2	Rivet, Eyebolt	15392
3	Eyebolt, Clamp Ring	3358
4	Washer	1870
5	Wing Nut, Eyebolt	78315
6	Clamp Ring 'B' w/Hose Support	N/A
7	Rubber Pad	79183
8	Confiner Tip	4120
9	Fill Cap, Indicator, w/Gasket	27335
10	Gasket, Fill Cap	3461
11	Housing, Indicator	17633
12	Stem, Indicator	27648
13	Quad Ring	17630
14	Retaining Ring	71675
15	Hose Assembly, 1 in. x 50 ft	2271
16	Gasket, Hose Coupling	445861
17	Hose and Adaptor Assembly, 3/8 in.	423581
18	Hose Assembly, 3/8 in., Regulator to Tank	N/A
19	Adaptor Union, Swivel	25582
20	Nameplate, Replacement w/o UL, FORAY	74338
20	Nameplate, Replacement w/o UL, PLUS-FIFTY C, Purple-K	16444
21	Nitrogen Cylinder Assembly, 220	24708
21	Nitrogen Cylinder Assembly, 220, QO Valve	31061
22	Cap, Nitrogen Cylinder	73066
23	Label, Nitrogen Cylinder Cap, QO Valve	11391
24	Label, Nitrogen Cylinder, Standard	3391
25	Label, Nitrogen Cylinder, QO Valve	10994
26	Valve Assembly, Nitrogen Cylinder, Standard & QO Valve	Pg. 64
27	Nozzle Assembly, Cone Tip, PLUS-FIFTY C, Pre-1976	31922
27	Nozzle Assembly, Purple-K, 1976-1988	31547
27	Nozzle Assembly, LR-44	25906
28	Ball Valve, Nozzle, Standard	12727
28	Ball Valve, Nozzle, LR-44	N/A
29	Gasket, Valve to Hose	445861
30	Body, Nozzle Assembly, Standard	29507
30	Body, Nozzle Assembly, Purple-K	31548
30	Body, Nozzle Assembly, LR-44	25907

*Regulator Replacement

See Manual Part No. 53141 – "Pressure Regulator Testing for Wheeled and Stationary Extinguishers"

Fig. No.	Description	Part No.
31	Gasket, Nozzle Assembly, Std	8105
31	Gasket, Nozzle Assembly, LR-44	12734
32	Sleeve, Nozzle Assembly,	8103
33	Tip, Nozzle Assembly, Cone Tip, PLUS-FIFTY C, Pre-1976	12707
34	Regulator Replacement	416938*
35	Pressure Relief Valve	78704
36	Support, Regulator	N/A
37	Wheel Assembly, Steel, Red	25908
38	Hub Cap	56739
39	Washer (3.3 mm)	67684
40	Washer (1.5 mm)	N/A
41	Bearing Assembly, Pre-1982	N/A
41	Bearing Assembly, Post-1982	68306
42	Pin, Spring	8560
43	Visual Hose Inspection Disc	14237
44	Gas Tube Assembly	77912
45	Cap Screws, Regulator Mounting	16301
46	Lockwasher, Regulator Mounting	1133
–	Strap, Regulator Mounting – (Not Shown)	N/A
–	Lockwasher, Regulator Mounting (2) (Not Shown)	14235
–	Hex Nut, Regulator Mounting (2) Not Shown)	14234
47	Hose Assembly, Regulator to Tank (2) (Option 1)	8748
48	Tee (Option 1)	3364
49	Regulator Assembly (Option 1), Replacement (Dual)	423456
49	Regulator Assembly (Option 2), Replacement (Dual)	423456
50	Nipple Assembly (Option 1)	N/A
50	Nipple Assembly (Option 2)	N/A
51	Mounting Strap (Option 1)	N/A
51	Mounting Strap (Option 2)	N/A
52	Adaptor, Nipple (Option 2)	N/A
53	Hose Assembly, 3/8 in. Nitrogen, HP (Option 2)	65049
54	Tee, 3/8 in. NPT (Option 2)	942
55	Nipple, 3/8 in. NPT (Option 2)	302
56	Elbow, 1/4 in. x 45 Street (Option 2)	16578
57	Hose Assembly, 3/8 in. Nitrogen, LP (Option 2)	8750

N/A = Not Available

WHEELED FIRE EXTINGUISHERS

Model CR-AR-33-D

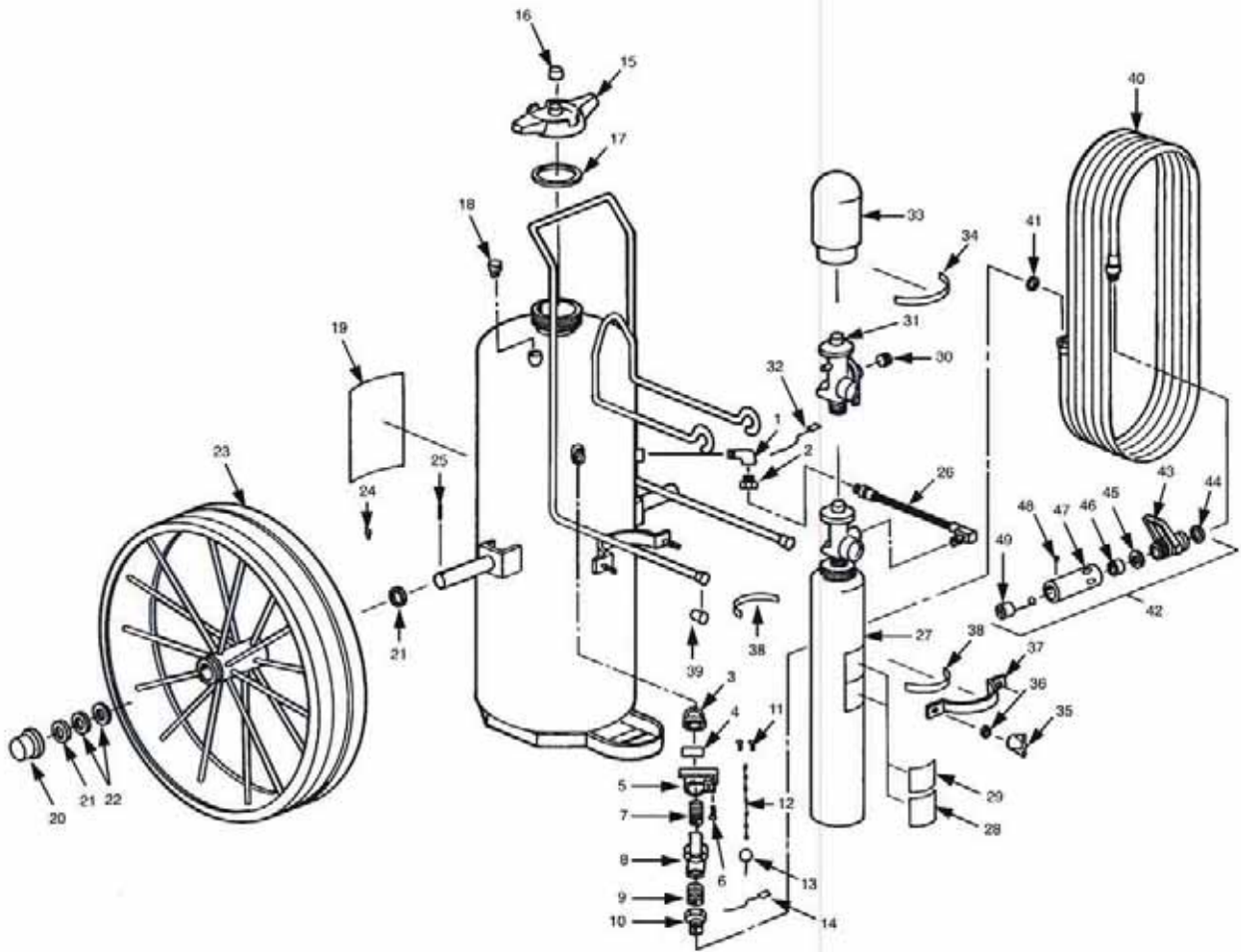

Model CR-AR-33-D

Fig. No.	Description	Part No.
1	Elbow, Street, 3/8 in. x 90°	53537
2	Bushing, Reducing, 3/8 x 1/4 in.	8390
3	Elbow, 3/4 in. x 45°	1967
4	Nameplate, Agent Valve	69887
5	Bracket Nameplate (w/Speed Nut)	N/A
6	Screw, Machine	57554
7	Nipple, 3/4 in.	1979
8	Valve, Butterfly, 3/4 in.	N/A
9	Nipple, Close, 3/4 in.	N/A
10	Adaptor	24930
11	Rivet, Pop (2)	25540
12	Chain, Ring Pin	2367
13	Pin, Ring	598
14	Seal, Visual Inspection	197
15	Cap, Fill, Assembly	67669
16	Cap, Indicator	17633
17	Gasket	67635
18	Relief, Safety	78380
19	Nameplate, Replacement w/o UL	70157
20	Cap, Hub (2)	56739
21	Washer (4) (1.5 mm)	N/A
22	Washer (4) (3.3 mm)	67684
23	Wheel, Wide (2)	31015
23	Wheel, Rubber Tire (2)	31012
24	Fitting, Alemite (2)	1033
25	Pin, Spring (2)	8560

Fig. No.	Description	Part No.
26	Nitrogen Hose Assembly	423581
27	Nitrogen Cylinder Assembly	54694
27	Nitrogen Cylinder Assembly, QO Valve	53882
28	Label, Nitrogen Cylinder	53182
29	Label, Nitrogen Cylinder, QO Valve	10994
30	Safety Plug, Nitrogen Cylinder, QO Valve	11453
31	Valve, Nitrogen Cylinder	Pg. 64
32	Seal, Visual Inspection	197
33	Cap, Cylinder Shipping	73066
34	Label, Nitrogen Cylinder Cap, QO Valve	11391
35	Wingnut (2)	78315
36	Washer (2)	1870
37	Clamp, Cylinder, Front	24877
38	Pad, Clamp Arm (2)	29748
39	Cap (2)	4120
40	Hose, 1 in. x 50 ft (15 m)	2271
41	Gasket, Hose	445861
42	Nozzle Assembly	53402
43	Valve, Ball	12727
44	Gasket, Valve to Hose	445861
45	Gasket, Nozzle to Valve	8105
46	Orifice, Metering	53405
47	Body, Nozzle	53663
48	Screw, Set	53666
49	Screen Assembly	53410
—	Tag, Inspection (Not Shown)	2364

Wheeled Assembly Parts

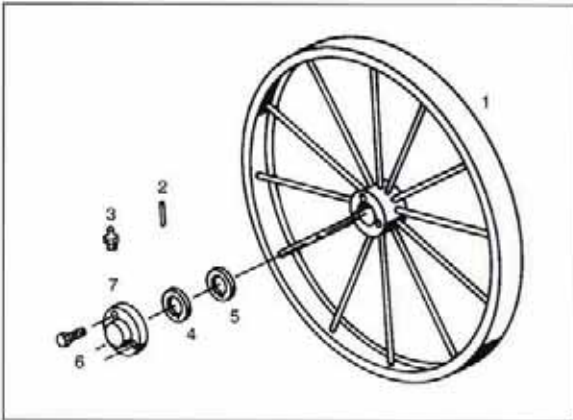

Model 150-A/B (Pre-1961) 3-Hole Bolt-On Hubcap

Fig. No.	Description	Part No.
1	Wheel, 2 1/2 in. Steel	29508
1	Wheel, Wide, 6 in. Steel	31015
1	Wheel, Rubber-Coated	31012
2	Spring Pin	8560
3	Alemite Fitting	1033
4	Washer (3.3 mm)	67684
5	Washer (1.5 mm)	N/A
6	Bolt	257
7	Hubcap	N/A

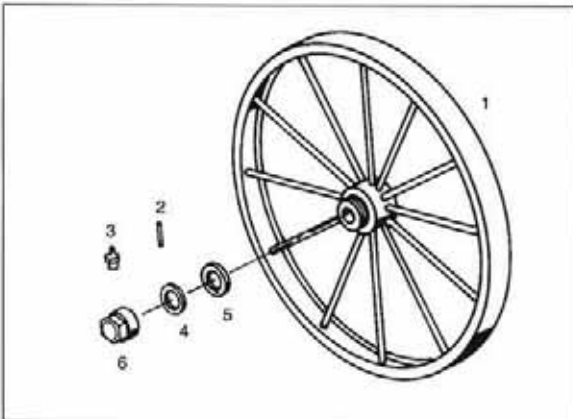

Model 150-B/C (1961-82) Threaded Hubcap

Fig. No.	Description	Part No.
1	Wheel, 2 1/2 in. Steel	29508
1	Wheel, Wide, 6 in. Steel	31015
1	Wheel, Rubber-Coated	31012
2	Spring Pin	8560
3	Alemite Fitting	1033
4	Washer (3.3 mm)	67684
5	Washer (1.5 mm)	N/A
6	Hubcap	N/A

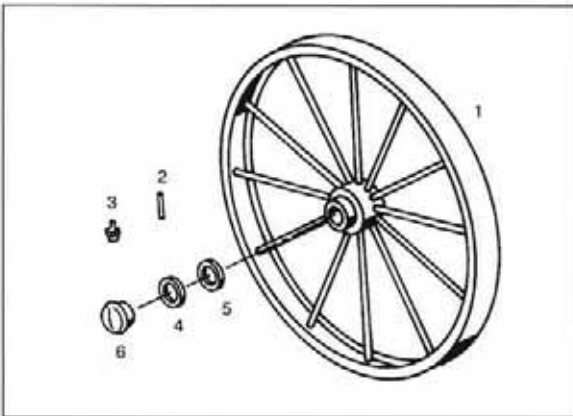

Model 150-C (Post-1982) Pop-On Hubcap

Fig. No.	Description	Part No.
1	Wheel, 2 1/2 in. Steel	29508
1	Wheel, Wide, 6 in. Steel	31015
1	Wheel, Rubber-Coated	31012
2	Spring Pin	8560
3	Alemite Fitting	1033
4	Washer (3.3 mm)	67684
5	Washer (1.5 mm)	N/A
6	Hubcap	56739

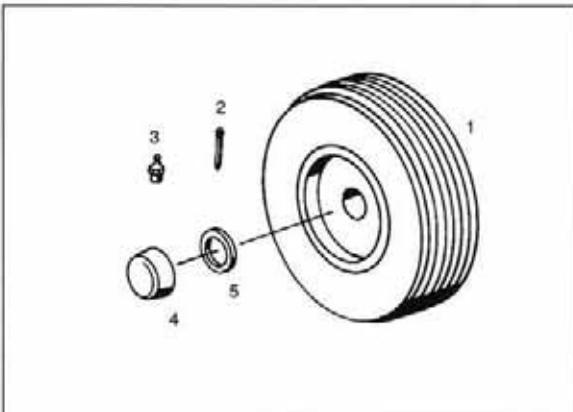

Model 150-D Vinyl Snap-On Hubcap

Fig. No.	Description	Part No.
1	Wheel, Steel	53870
2	Roll Pin	69855
3	Alemite Fitting	1033
4	Washer	53541
5	Hubcap	53867

N/A = Not Available

Wheeled Assembly Parts

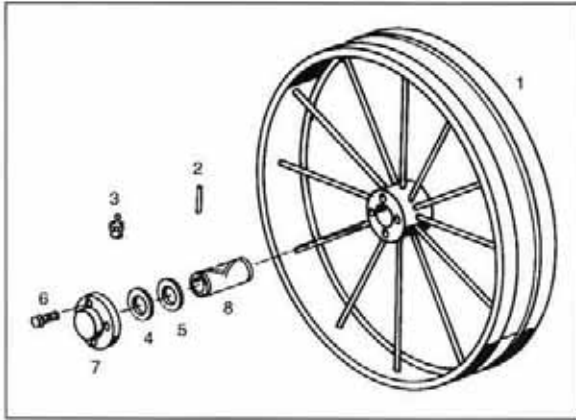

**Model 350-A/B/C (Pre-1982)
4-Hole Bolt-On Hubcap**

Fig. No.	Description	Part No.
1	Wheel, Wide, 6 in. Steel	N/A
2	Spring Pin	8560
3	Alemite Fitting	1033
4	Washer (3.3 mm)	67684
5	Washer (1.5 mm)	67685
6	Bolt	N/A
7	Hubcap, CR	N/A
8	Bearing Assembly	N/A

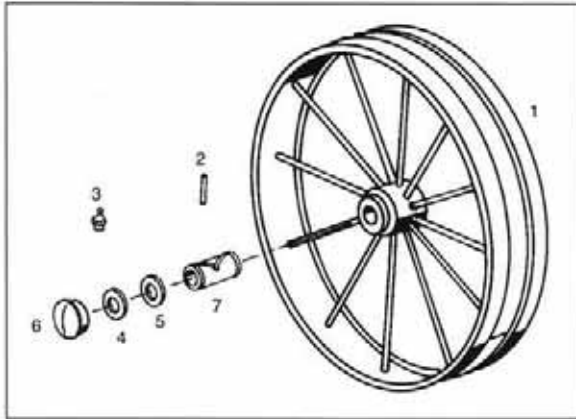

Model 350-C (Post-1982) Pop-On Hubcap

Fig. No.	Description	Part No.
1	Wheel, Wide, 6 in. Steel	25908
2	Spring Pin	8560
3	Alemite Fitting	1033
4	Washer (3.3 mm)	67684
5	Washer (1.5 mm)	N/A
6	Bolt	N/A
7	Hubcap	56739

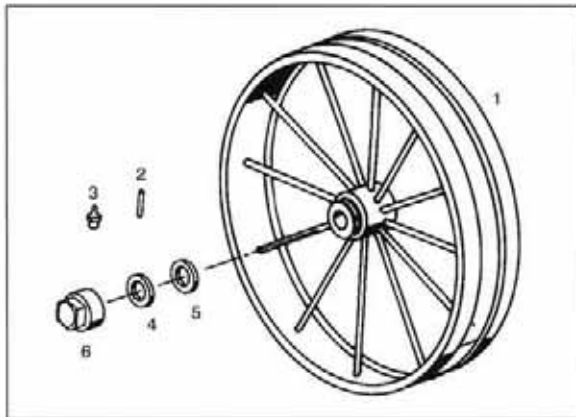

**Model 350-D and 33-D (1980-1982)
Threaded Hubcap**

Fig. No.	Description	Part No.
1	Wheel, Wide, 6 in. Steel	31015
1	Wheel, Rubber-Coated	31012
2	Spring Pin	8560
3	Alemite Fitting	1033
4	Washer (3.3 mm)	67684
5	Washer (1.5 mm)	N/A
6	Hubcap	N/A

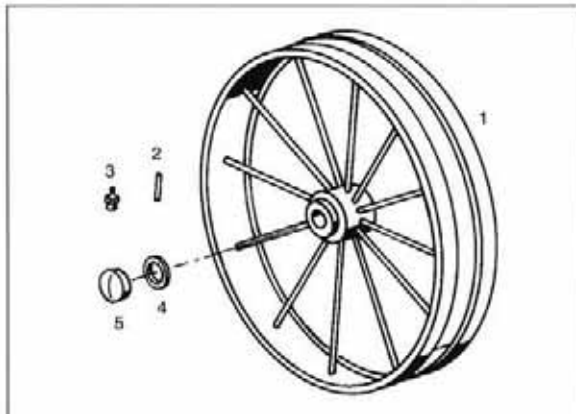

**Model 350-D and 33-D (Post-1982)
Pop-On Hubcap**

Fig. No.	Description	Part No.
1	Wheel, Wide, 6 in. Steel	31015
1	Wheel, Rubber-Coated	31012
2	Spring Pin	8560
3	Alemite Fitting	1033
4	Washer (3.3 mm)	67684
5	Hubcap	56739

N/A = Not Available

Wheeled Extinguisher Nitrogen Cylinder Valve Parts

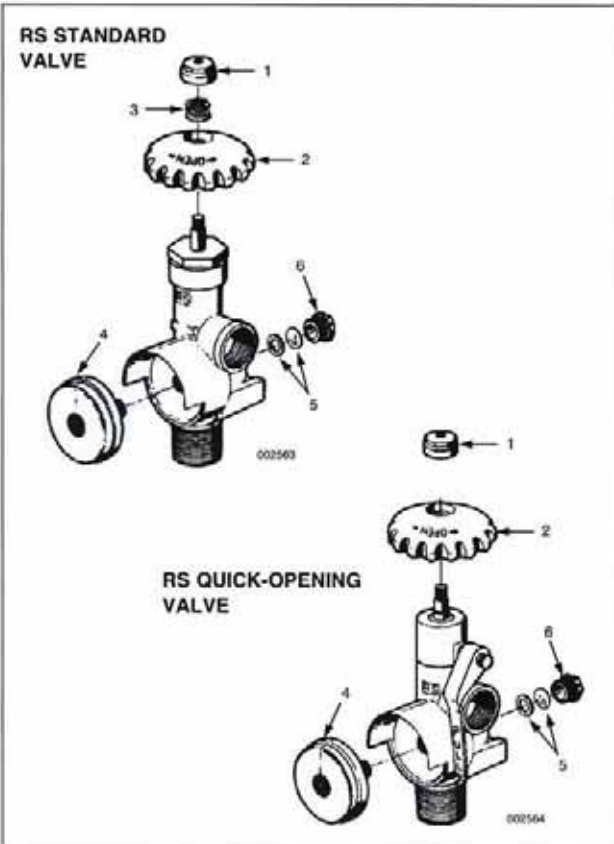

Nitrogen Cylinder Valve Parts – Standard & Quick-Opening (QO)

Fig. No.	Part No.	Description
-	78706	Valve Assembly, (RS) Std, 22/55/110/220 ft ³ (0.7/1.6/3.1/6.2 m ³)
-	78705	Valve Assembly, (RS) QO, 22/55/110/220 ft ³ (0.7/1.6/3.1/6.2 m ³)
-	419100	Valve Assembly, (RS) QO, 300/400 ft ³ (8.5/11.3 m ³)
1	78710	Nut, Handwheel
2	N/A	Handwheel
3	N/A	Spring, Std Valve Only
4	78707	Gauge
5	78711	Safety Disc & Washer
5	419109	Safety Disc & Washer, QO, 300/400
6	78709	Plug, Safety Relief

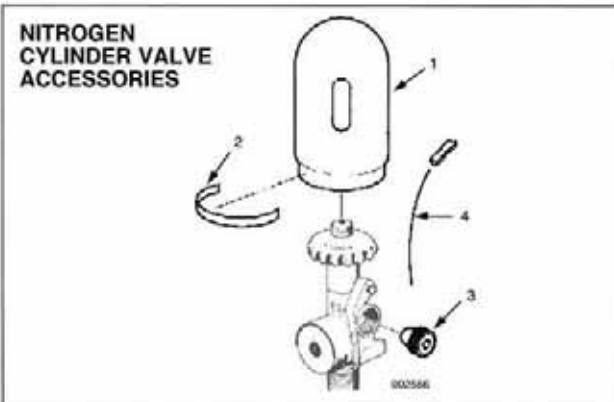

Nitrogen Cylinder Valve Accessories

Fig. No.	Part No.	Description
1	73066	Shipping Cap, Nitrogen Cylinder
2	11391	Label, Shipping Cap
3	11453	Plug, Safety Shipping
4	15999	Inspection Seal

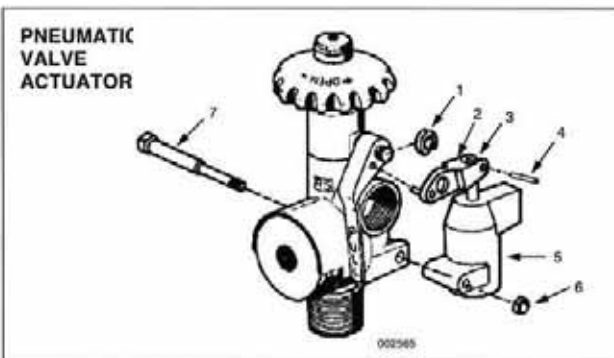

Pneumatic Actuator Parts (Quick-Opening Valve Only)

Fig. No.	Part No.	Description
-	11160	Actuator Assembly, QO Valve
1	11322	Ring, Crescent
2	11389	Arm, Actuator
3	11301	Rod, Actuator
4	11172	4 Pin, Roll
5	11161	Body, Actuator
6	11173	Nut, Cap
7	11171	Stud, Anchor

Wheeled Extinguisher Nozzle Identification Chart

CONE TIP STYLES

ANSUL BODY PART NO.

Part No. Corrosion Resistant	Cone Tip Stamp	ANSUL Cone Tip Part No.
29507	#16	12703
	#25	12707
	#24	15478
	#23	8104 (HF-35)
	(N/A) Painted Red	10059 (HF-70)

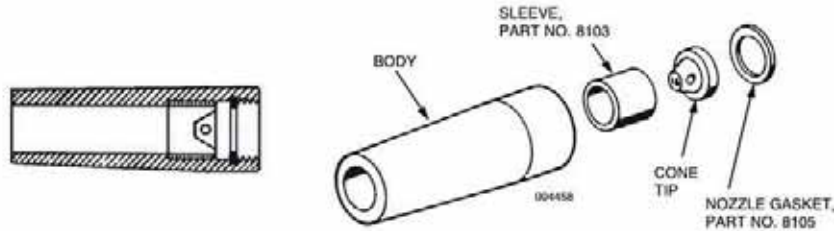

LONG RANGE (LR) STYLES

ANSUL BODY PART NO.

Nozzle Body Stamp	Corrosion Resistant
LR-36	31014 - All 150-C/150-D
LR-44	25907 - All 350-C/350-D

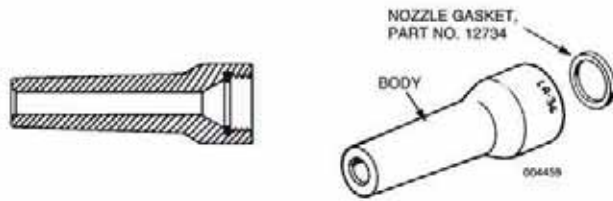

FOAM STYLE

Nozzle Body Stamp
AFFF

ANSUL Nozzle Body
Part No.

53663 - AR-33-D

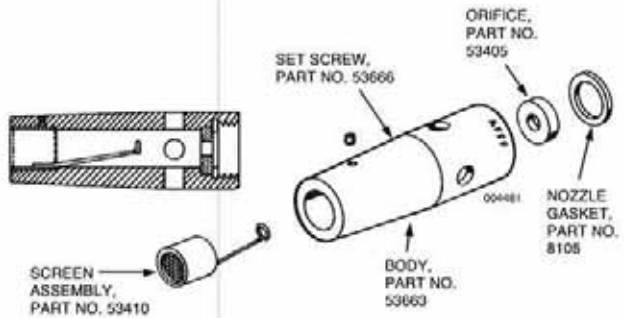

CONVERGING/DIVERGING STYLES

ANSUL BODY PART NO.

Nozzle Body Stamp	Corrosion Resistant
52	53882 - CR-I, CR-A-350-D
30/0	31548 - CR-K-350-C
23/3	31448 - All 150-C/150-D Models
425	53889 - CR-K-350-D

